

SONY®

PROFESSIONAL DISC RECORDER

PDW-R1

XDCAM™
Professional Disc System

Professional Disc

MPEG IMX

DVCAM™



OPERATION MANUAL
1st Edition (Revised 1)

English

Important Safety Instructions

- Read these instructions.
- Keep these instructions.
- Heed all warnings.
- Follow all instructions.
- Do not use this apparatus near water.
- Clean only with dry cloth.
- Do not block any ventilation openings.
- Install in accordance with the manufacturer's instructions.
- Do not install near any heat sources such as radiators, heat registers, stoves, or other apparatus (including amplifiers) that produce heat.
- Do not defeat the safety purpose of the polarized or grounding-type plug. A polarized plug has two blades with one wider than the other. A grounding-type plug has two blades and a third grounding prong. The wide blade or the third prong are provided for your safety. If the provided plug does not fit into your outlet, consult an electrician for replacement of the obsolete outlet.
- Protect the power cord from being walked on or pinched particularly at plugs, convenience receptacles, and the point where they exit from the apparatus.
- Only use attachments/accessories specified by the manufacturer.
- Use only with the cart, stand, tripod, bracket, or table specified by the manufacturer, or sold with the apparatus. When a cart is used, use caution when moving the cart/apparatus combination to avoid injury from tip-over.



- Unplug this apparatus during lightning storms or when unused for long periods of time.
- Refer all servicing to qualified service personnel. Servicing is required when the apparatus has been damaged in any way, such as power-supply cord or plug is damaged, liquid has been spilled or objects have fallen into the apparatus, the apparatus has been exposed to rain or moisture, does not operate normally, or has been dropped.

WARNING

To reduce the risk of fire or electric shock, do not expose this apparatus to rain or moisture.

To avoid electrical shock, do not open the cabinet. Refer servicing to qualified personnel only.

THIS APPARATUS MUST BE EARTHED.

CAUTION

The apparatus shall not be exposed to dripping or splashing and no objects filled with liquid, such as vases, shall be placed on the apparatus.

The unit is not disconnected from the AC power source (mains) as long as it is connected to the wall outlet, even if the unit itself has been turned off.

Do not install the appliance in a confined space, such as a book case or built-in cabinet.

This apparatus is provided with a main switch on the rear panel. Install this apparatus so that user can access the main switch easily.

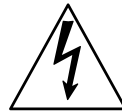
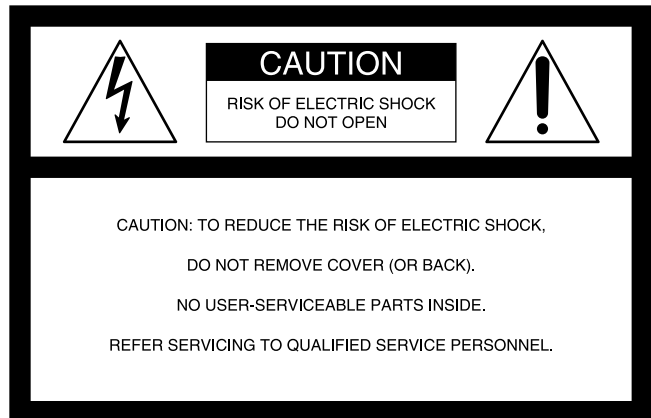

This symbol is intended to alert the user to the presence of uninsulated "dangerous voltage" within the product's enclosure that may be of sufficient magnitude to constitute a risk of electric shock to persons.



This symbol is intended to alert the user to the presence of important operating and maintenance (servicing) instructions in the literature accompanying the appliance.

WARNING: THIS WARNING IS APPLICABLE FOR USA ONLY.

If used in USA, use the UL LISTED power cord specified below.

DO NOT USE ANY OTHER POWER CORD.

Plug Cap	Parallel blade with ground pin (NEMA 5-15P Configuration)
Cord Length	Type SJT, three 16 or 18 AWG wires Minimum 1.5 m (4 ft. 11 in.), Less than 2.5 m (8 ft. 3 in.)
Rating	Minimum 10 A, 125 V

Using this unit at a voltage other than 120 V may require the use of a different line cord or attachment plug, or both. To reduce the risk of fire or electric shock, refer servicing to qualified service personnel.

WARNING: THIS WARNING IS APPLICABLE FOR OTHER COUNTRIES.

1. Use the approved Power Cord (3-core mains lead)/Appliance Connector/Plug with earthing-contacts that conforms to the safety regulations of each country if applicable.
2. Use the Power Cord (3-core mains lead)/Appliance Connector/Plug conforming to the proper ratings (Voltage, Ampere).

If you have questions on the use of the above Power Cord/ Appliance Connector/Plug, please consult a qualified service personnel.

When installing the installation space must be secured in consideration of the ventilation and service operation.

- Do not block the ventilation slots at the left side and right side panels, and vents of the fans.
- Leave a space around the unit for ventilation.
- Leave more than 40 cm of space in the rear of the unit to secure the operation area.

When the unit is installed on the desk or the like, leave at least 4 cm of space in the left and right sides.

Leaving 40 cm or more of space above the unit is recommended for service operation.

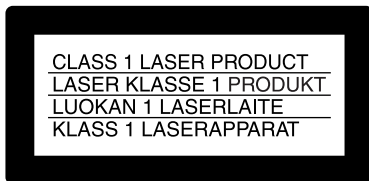

This Professional Disc Recorder is classified as a CLASS 1 LASER PRODUCT.

Laser diode properties

Wavelength: 403 to 410 nm

Emission duration: Continuous

Laser output power: 65 mW (max. of pulse peak), 35 mW (max. of CW)

Tekniska data för laserdiod

Våglängd: 403 till 410 nm

Emissionslängd: Kontinuerlig

Laserut effekt: 65 mW (max. för pulstopp), 35 mW (max. för kontinuerlig våg)

Spesifikasjoner laserdiode

Bølgelengde: 403 til 410 nm

Strålingens varighet: Kontinuerlig

Laserens effekt: 65 mW (maks stråletpunkt), 35 mW (maks ved kontinuerlig stråling)

Laserdiodin ominaisuudet

Aallon pituus: 403 - 410 nm

Välilyksen kesto: Jatkuva

Laserlähdon teho: 65 mW (sykehuipun maks.), 35 mW (jatkuvan aallon maks.)

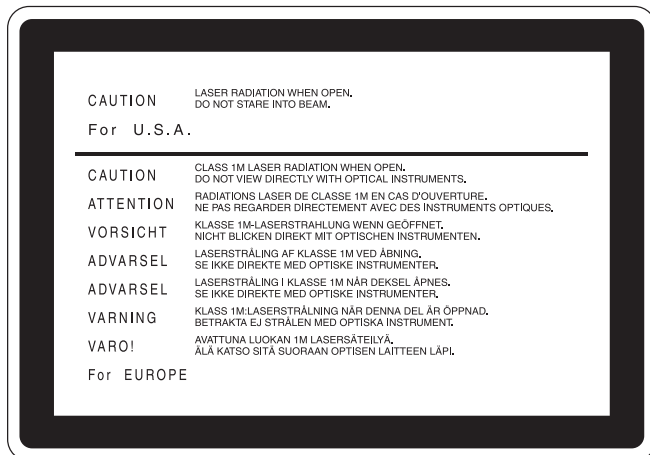

This label is located on the top panel of the drive unit.

Denna etikett finns på ovensidan av driftenheten.

Denne mærkat sidder på drevenhedens øverste panel.

Tämä kyltti sijaitsee ajurilaitteen yläpinnalla.

Dette merket er plassert på oversiden av driverenheten.

CAUTION

The use of optical instruments with this product will increase eye hazard.

CAUTION

Use of controls or adjustments or performance of procedures other than those specified herein may result in hazardous radiation exposure.

VAROITUS!

LAITTEEN KÄYTTÄMINEN MUULLA KUIN TÄSSÄ KÄYTTÖOHJEESSA MAINITULLA TAVALLA SAATTAA ALTISTAA KÄYTTÄJÄN TURVALLISUUSLUOKAN 1 YLITTÄVÄLLE NÄKYMÄTTÖMÄLLE LASERSÄTEILYLLE.

VARNING

OM APPARATEN ANVÄNDS PÅ ANNAT SÄTT ÄN I DENNA BRUKSANVISNING SPECIFICERATS, KAN ANVÄNDAREN UTSÄTTAS FÖR OSYNLIG LASERSTRÅLNING, SOM ÖVERSKRIDER GRÄNSEN FÖR LASERKLASS 1.

For the customers in the USA

This equipment has been tested and found to comply with the limits for a Class B digital device, pursuant to Part 15 of the FCC Rules. These limits are designed to provide reasonable protection against harmful interference in a residential installation. This equipment generates, uses, and can radiate radio frequency energy and, if not installed and used in accordance with the instructions, may cause harmful interference to radio communications. However, there is no guarantee that interference will not occur in a particular installation. If this equipment does cause harmful interference to radio or television reception, which can be determined by turning the equipment off and on, the user is encouraged to try to correct the interference by one or more of the following measures:

- Reorient or relocate the receiving antenna.
- Increase the separation between the equipment and receiver.
- Connect the equipment into an outlet on a circuit different from that to which the receiver is connected.
- Consult the dealer or an experienced radio/TV technician for help.

You are cautioned that any changes or modifications not expressly approved in this manual could void your authority to operate this equipment.

All interface cables used to connect peripherals must be shielded in order to comply with the limits for a digital device pursuant to Subpart B of Part 15 of FCC Rules.

For the customers in the USA and Canada
RECYCLING LITHIUM-ION BATTERIES

Lithium-Ion batteries are recyclable.
You can help preserve our environment
by returning your used rechargeable
batteries to the collection and recycling
location nearest you.



For more information regarding recycling of rechargeable
batteries, call toll free 1-800-822-8837, or visit
<http://www.rbc.org/>

Caution: Do not handle damaged or leaking lithium-ion
batteries.

For the customers in Europe

This product with the CE marking complies with both the EMC
Directive (89/336/EEC) and the Low Voltage Directive (73/23/
EEC) issued by the Commission of the European Community.
Compliance with these directives implies conformity to the
following European standards:

- EN60065: Product Safety
- EN55103-1: Electromagnetic Interference (Emission)
- EN55103-2: Electromagnetic Susceptibility (Immunity)

This product is intended for use in the following

Electromagnetic Environment(s):

E1 (residential), E2 (commercial and light industrial), E3
(urban outdoors) and E4 (controlled EMC environment, ex. TV
studio).

WARNING

Excessive sound pressure from earphones and headphones
can cause hearing loss.

In order to use this product safely, avoid prolonged listening at
excessive sound pressure levels.

Voor de Klanten in Nederland

- Gooi de batterij niet weg maar lever deze in als klein
chemisch afval (KCA).
- Dit apparaat bevat een vast ingebouwde batterij die niet
vervangen hoeft te worden tijdens de levensduur van het
apparaat.
- Raadpleeg uw leverancier indien de batterij toch vervangen
moet worden.
De batterij mag alleen vervangen worden door vakbekwaam
servicepersoneel.
- Lever het apparaat aan het einde van de levensduur in voor
recycling, de batterij zal dan op correcte wijze verwerkt
worden.

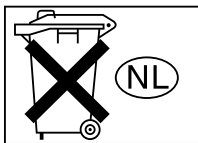

For the Customers in Taiwan only



廢電池請回收

Table of Contents

Before Using the Unit	7
Setting the Line Mode	7

Chapter 1 Overview

1-1 Features	9
---------------------------	----------

Chapter 2 Names and Functions of Parts

2-1 Configuration	11
2-2 Control Panel.....	12
2-3 LCD Panel	17
2-4 Connectors	21

Chapter 3 Preparations

3-1 Connections and Settings.....	25
3-1-1 Connecting an External Monitor	25
3-1-2 Connections for Using PDZ-1 Proxy Browsing Software	25
3-1-3 Connecting to a Nonlinear Editing System.....	27
3-1-4 Connections for Recording in Parallel With a Camcorder.....	27
3-1-5 Connections for Cut Editing	29
3-1-6 Using the RM-280 Editing Controller	31
3-1-7 Editing Control Unit Settings	32
3-2 Power Preparations	33
3-2-1 Using AC Power.....	33
3-2-2 Using DC Power.....	33
3-2-3 Using a Battery Pack	33
3-3 Setup	34
3-4 Setting the Date and Time.....	34
3-5 Superimposed Text Information.....	35
3-6 Handling Discs	38
3-6-1 Discs Used for Recording and Playback.....	38
3-6-2 Notes on Handling	38
3-6-3 Write-Protecting Discs	38
3-6-4 Loading and Unloading a Disc	38
3-6-5 Formatting a Disc	39
3-6-6 To Eject Discs With the Unit Powered Off.....	39
3-6-7 Handling of Discs When Recording Does Not End Normally (Salvage	

Function).....	40
----------------	----

Chapter 4 Recording/Playback

4-1 Recording	42
4-1-1 Preparations for Recording	42
4-1-2 Recording Time Code and User Bit Values	44
4-1-3 Recording Operation.....	48
4-1-4 Auto Clip List Recording for Automatic Inclusion of Recorded Clips in Clip Lists.....	48
4-2 Playback	49
4-2-1 Preparations for Playback.....	49
4-2-2 Playback Operation.....	51
4-2-3 Thumbnail Search.....	52
4-2-4 Clip List Playback.....	54
4-2-5 Repeat Playback.....	54
4-2-6 Locking and Deleting Clips.....	55

Chapter 5 Scene Selection

5-1 Overview	58
5-2 Creating Clip Lists	61
5-2-1 Selecting Clips	61
5-2-2 Reordering Sub Clips.....	63
5-2-3 Trimming Sub Clips	65
5-2-4 Deleting Sub Clips	66
5-2-5 Previewing the Current Clip List.....	66
5-2-6 Saving the Current Clip List to Disc	66
5-3 Managing Clip Lists (CLIP Menu)....	68
5-3-1 Loading a Clip List From Disc Into Unit Memory.....	68
5-3-2 Deleting Clip Lists From a Disc	69
5-3-3 Clearing the Current Clip List From the Unit Memory.....	69
5-3-4 Presetting the Initial Time Code of the Current Clip List	69
5-3-5 Sorting Clip Lists.....	70
5-4 Using PDZ-1 Proxy Browsing Software	71

Chapter 6 File Operations

6-1 Overview	72
6-1-1 Directory Structure	72
6-1-2 File Operation Restrictions	73

- 6-1-3 Assigning User-Defined Clip Titles 75
- 6-1-4 Assigning User-Defined Clip and Clip List Names 76
- 6-2 File Access Mode File Operations... 78**
- 6-2-1 Making FAM Connections 78
- 6-2-2 Operating on Files 79
- 6-2-3 Exiting File Operations..... 79
- 6-3 FTP File Operations 80**
- 6-3-1 Making FTP Connections 80
- 6-3-2 Command List 82
- 6-4 Recording Continuous Time Code With FAM and FTP Connections..... 88**

- Index..... 151**

Chapter 7 Menus

- 7-1 Menu System Configuration 89**
- 7-2 Basic Setup Menu 90**
- 7-2-1 Items in the Basic Setup Menu 90
- 7-2-2 Basic Menu Operations 94
- 7-3 Extended Menu 97**
- 7-3-1 Items in the Extended Menu 97
- 7-3-2 Extended Menu Operations 108
- 7-3-3 Using UMID Data 109
- 7-4 Maintenance Menu 112**
- 7-4-1 Items in the Maintenance Menu 112
- 7-4-2 Maintenance Menu Operations..... 114
- 7-5 System Menu 117**
- 7-5-1 Items in the System Menu 117
- 7-5-2 System Menu Operations..... 117

Chapter 8 Maintenance and Troubleshooting

- 8-1 Periodic Maintenance 120**
- 8-1-1 Digital Hours Meter 120
- 8-2 Condensation 121**
- 8-3 Error Messages 121**
- 8-4 Alarms 122**
- 8-4-1 Alarm List..... 122

Appendixes

- Specifications 131**
- Using the Shoulder Belt 134**
- Notice Concerning the Software License of This Unit..... 135**
- MPEG-4 Visual Patent Portfolio License..... 148**
- Glossary 149**

Before Using the Unit

Setting the Line Mode

This unit is shipped with the line mode still unset. Therefore you need to set the line mode before using the unit. (The unit cannot be used unless the line mode is set.) Once it is set, the line mode is retained even when the unit is powered off.

Setting procedure

Use the following procedure to set the line mode.

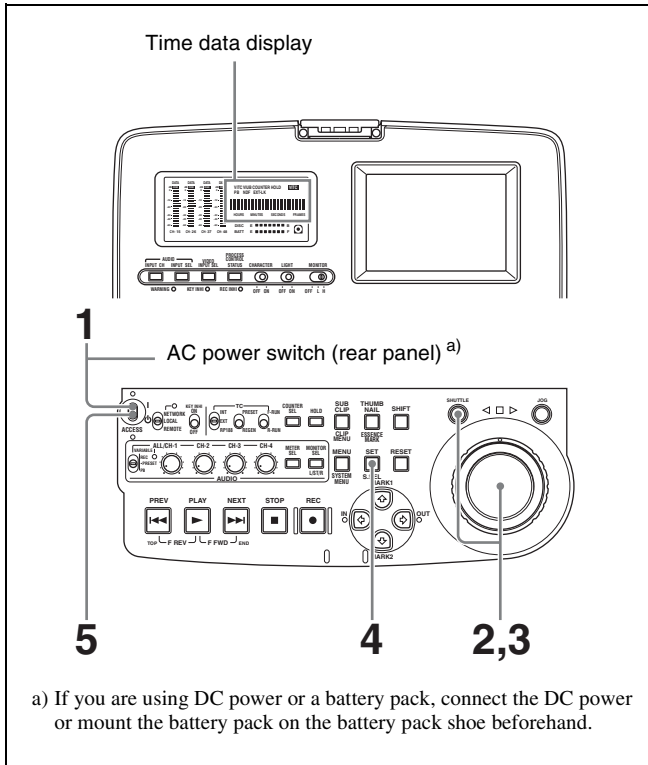

1 Power the unit on.

“Select ----” appears in the time data display.



2 With the SHUTTLE button held down, rotate the jog dial.

When you rotate the jog dial in the forward direction, the “----” part of the display changes in the sequence 525U > 525J > 625. When you rotate it in the reverse direction, the display changes in the sequence 625 > 525J > 525U.

Select 525U

Setting	Line mode
525U	525(U): NTSC (areas outside Japan)
525J	525(J): NTSC (Japan)
625	625: PAL

3 When the desired setting appears, release the SHUTTLE button.

“Push SET !!” appears.

Push SET !!

To redo the selection

Repeat step 2.

4 Press the SET button.

“Turn OFF !!” appears.

Turn OFF !!

5 Power the unit off, and then power it on again.

The selected line mode becomes available for use.

You can change the setting made with this procedure by using basic menu item 013 “525/625 SYSTEM SELECT.” See 7-2-2 “Basic Menu Operations” (page 94) for more information about how to make basic menu settings.

Note

The line mode is not set, or is cleared, in the following situations. Reset the line mode.

- The unit is powered off before performing step 4 in the previous procedure.
- The “RESET ALL SETUP” command in the maintenance menu (see page 112) is executed.

Settings affected by the line mode

The following settings are affected when the line mode is changed.

- Alarm message language
525(J): Japanese
525(U)/625: English
- The following menu item names, setting values, or factory default setting values

Item No.	Item name	Settings ^{a)}	
		525 (U)/525 (J)	625
Basic menu			
002	CHARACTER H-POSITION	00 to <u>0A</u> to 2A	00 to <u>09</u> to 29
003	CHARACTER V-POSITION	00 to <u>2E</u> to 38	00 to <u>37</u> to 43
Extended menu			
601	VITC POSITION SEL-1	12H to <u>16H</u> to 20H	9H to <u>19H</u> to 22H
602	VITC POSITION SEL-2	12H to <u>18H</u> to 20H	9H to <u>21H</u> to 22H
628	DF MODE	Item	No item
652	UMID SDI VANC LINE	12 H to <u>17 H</u> to 19 H	9 H to <u>17 H</u> to 18 H
660	ESSENCE MARK SDI VANC LINE	12 H to <u>17 H</u> to 19 H	9 H to <u>17 H</u> to 18 H
703	BLANK LINE SELECT	Setting range: ALL LINE, LINE 12 to LINE 20 (525(U))/LINE 12 to LINE 21 (525(J))	Setting range: ALL LINE, LINE 9, 332 to LINE 22, 335, LINE 23
710	INTERNAL VIDEO SIGNAL GENERATOR	BB, <u>CB75</u> , CB100	BB, CB75, <u>CB100</u>
713	VIDEO SETUP REFERENCE	Item	No item
723	INPUT VIDEO BLANK	Setting range: ALL LINE, LINE 12 to LINE 20	Setting range: ALL LINE, LINE 9, 332 to LINE 22, 335

a) Underlined values are the factory defaults.

- The following video processing parameters

Parameter name	525 (U)/525 (J)	625
Setup level	Item	No item
Black level	No item	Item

1-1 Features

The PDW-R1 is a convenient, compact, and lightweight optical disc recorder. It allows you to record to optical discs, play back optical discs, and record audio and video data files transferred over the iS400 (i.LINK¹⁾) connector and  (network) connector. It is ideal for field applications and for desktop viewing by journalists, producers, and other production staff.

1) i.LINK is a trademark of Sony Corporation.

The features of the PDW-R1 include the following.

MPEG IMX/DVCAM recording

The PDW-R1 offers the capability to record and play back both MPEG IMX¹⁾ and DVCAM¹⁾ streams. Users have the flexibility to select from these formats according to their picture-quality needs, or to match their editing-format requirements.

1) MPEG IMX and DVCAM are trademarks of Sony Corporation.

Proxy AV data

Proxy AV data is a low-resolution, MPEG-4 based version of a full-resolution MPEG IMX/DVCAM stream (a video bandwidth of 1.5 Mbps and an audio bandwidth of 64 kbps per channel). Whenever a recording is made, the unit automatically generates proxy AV data from the full-resolution data and records it on the Professional Disc. Proxy AV data is much smaller in size than the full-resolution IMX or DVCAM data. It can be transferred quickly over computer networks, easily edited in the field with laptop computers, and readily used in a wide variety of applications, such as content management on small-scale servers.

Thumbnail search operation

Simply press the THUMBNAIL button and the PDW-R1 instantly displays thumbnails on the video panel or a connected monitor. You can easily cue up the desired scene by guiding the cursor to the corresponding thumbnail and confirming your selection with the SET button.

Scene selection



You can create and play back clip lists of selected clips from the disc, arranged in any order. One disc can store up to 99 clip lists. Clip lists make it simple to perform offline editing in the field for later use with full-scale nonlinear editing systems (XPRI¹⁾, etc.).

1) XPRI is a trademark of Sony Corporation.

Quick picture search by jog and shuttle dials

The PDW-R1 has jog and shuttle dials as a conventional VTR to search picture in a clip. The jog dial is for frame-by-frame search at -1 to +1 times normal speed and the shuttle dial is for high-speed search at ± 20 times normal speed.

IT-friendly system

In the PDW-R1, clips are recorded as video and audio data files¹⁾. This file-based recording system also allows material to be viewed directly on a computer linked to the unit via an i.LINK (file access mode, called FAM below) connection—in the same way that a computer reads data files on an external drive. The interfaces include the iS400 (i.LINK) connector, supporting AV/C (Audio/Video Control) and i.LINK (FAM) protocols, and  (network) connector. The  (network) connector supports MXF (Material eXchange Format) file transfer capability to exchange contents with other equipment supporting MXF.

- 1) A clip is created every time recording is stopped.
- Video and audio data are always recorded in empty sections of the disc. Recording begins instantly, even after playback, without overwriting existing video on the disc.
 - Recording is done in clip units, which makes it simple to delete a clip immediately after shooting if it is judged to be unneeded.
 - During playback, thumbnail lists make it easy to identify clips. The random access nature of the media allows the NEXT and PREV buttons to jump instantly to clip start frames, making it easy to check the video and audio in the clips.
 - i.LINK (FAM) or network connections make it possible to transfer clip files at high speed between this unit and remote computers.

Flexible metadata recording

XDCAM¹⁾ can record various types of metadata together with video and audio data, such as the date and time of shooting, the cameraman, the recording method, and comments about the material. This metadata can be used in applications such as the following.

- The supplied PDZ-1 Proxy Browsing Software can be used to add titles, comments, and other text data to discs and clips.
- Computer-readable text files can be recorded on the Professional Disc, to allow systematic content management.
- The ability to search metadata for the required audio and video scenes brings greater efficiency to various stages of the video production process (editing, archiving, etc.).

1) XDCAM is a trademark of Sony Corporation.

Supports a variety of interfaces

The PDW-R1 supports a variety of interfaces and is suitable for use with various nonlinear editing systems.

Analog interfaces

Video: The unit can input and output a composite analog video signal.

Audio: The unit has two audio channels. When in 4-channel mode, you can input two channels of audio either as channels 1 and 2 or as channels 3 and 4. The two audio channels can be output also either as channels 1 and 2 or as channels 3 and 4.

Digital interfaces

SDI (Serial Digital Interface)/AES/EBU: This allows the unit to input and output D1 (component) format digital video and audio signals and also AES/EBU-format digital audio signals.

Equipped with i.LINK connector

The i.LINK connector of this unit supports the following two functions.

Input and output of DV streams (AV/C mode)

- DV streams can be output from this unit and recorded on standard DV equipment.
- During MPEG IMX playback, the playback signals can be converted and output as DV streams, allowing you to connect DV-compatible nonlinear editors.

- The output from external DV devices (VTRs, nonlinear editors, etc.) can be input to this unit and recorded on Professional Discs.

Computer access to files (file access mode)

Use of application software which supports the XDCAM series¹⁾ enables random access to video, audio, and metadata files on Professional Discs, with the ability to display file lists and perform file-based reads and overwrites.

Files can be transferred at high speed, and thumbnail lists of disc contents can be viewed on computer screens.

1) Such software includes the supplied PDZ-1 Proxy Browsing Software and the XPRI series.

Equipped with network connector

This network connector of unit can be connected to computers and networks to enable high-speed file transfers and display of lists of the video, audio, and metadata files stored on Professional Discs. Workflows can be improved by the ability to use FTP commands to transfer files to remote locations.

Color LCD built-in

With the built-in 3.5-inch type color LCD screen, you can display contents on the disc without an external monitor.

Compact size, lightweight and battery-powered operation

The PDW-R1 is designed small and light enough to carry out to the field and it is operable with battery to work speedily in the field.

Supporting SNMP for service and maintenance

The PDW-R1 is compatible with Sony remote maintenance and monitoring software—an SNMP-compliant application that can monitor and log the hardware's status in real time via a TCP/IP network. If a malfunction is detected, this system can immediately identify the problem, allowing you to take corrective action.

Names and Functions of Parts

Chapter 2

2-1 Configuration

Operation of the PDW-R1 uses the parts shown in the following figure.

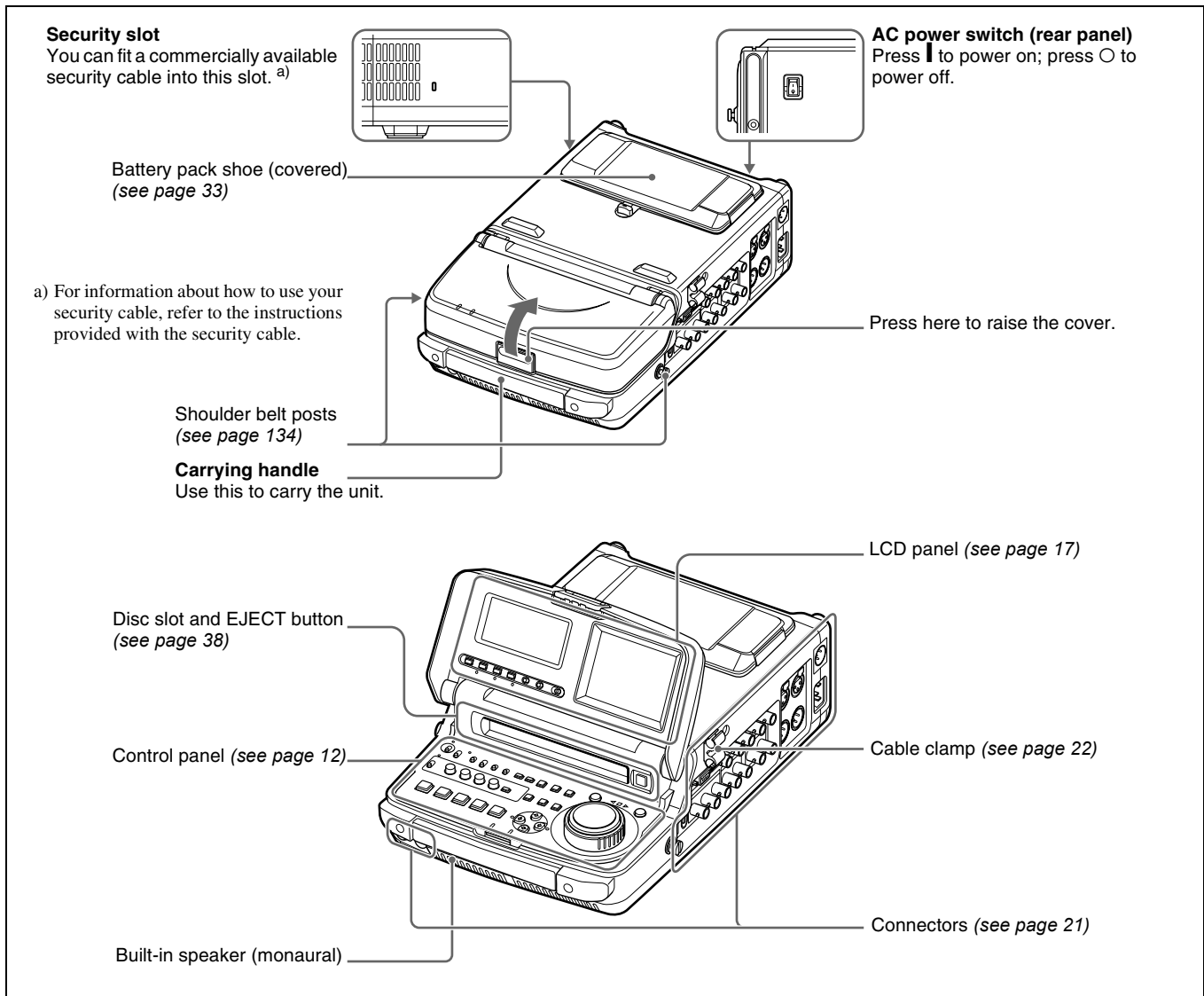

2-2 Control Panel

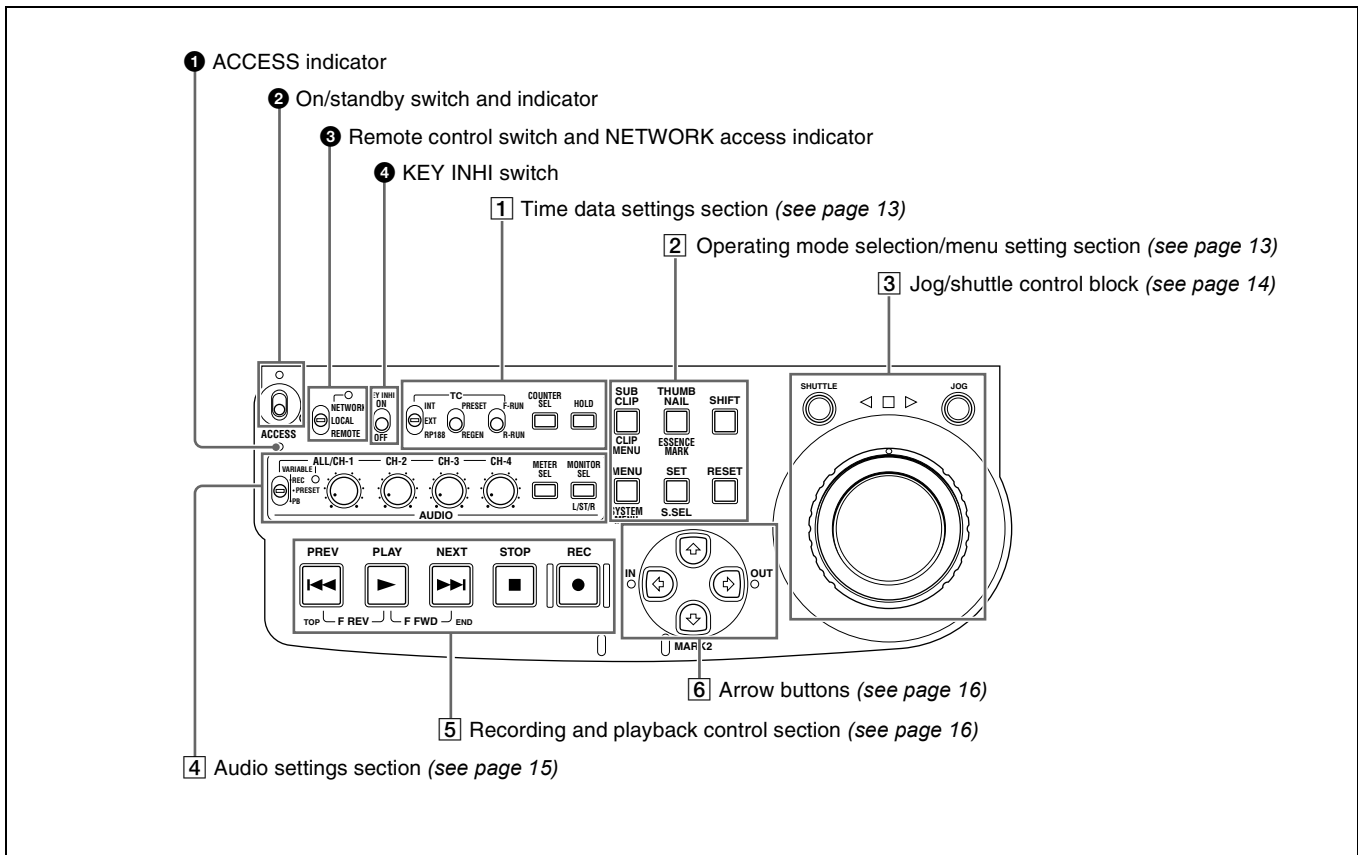



1 ACCESS indicator

This lights when the disc is accessed and when a file is opened by a FAM or FTP connections (see page 72). If the on/standby switch is set to the  position while this indicator is lit, access to the disc is completed before the unit switches to the standby state.

Note

While the ACCESS indicator is lit, do not turn off the AC power switch, disconnect the power cord, or remove the battery. This could lead to a loss of data from the disc.

2 On/standby (I/⏻) switch and indicator

When the AC power switch on the rear panel is in the **I** position, or a battery is loaded, this switches the PDW-R1 between the operating (**I**) and standby () states. When the switch is moved to the **I** position, the indicator lights. When the switch is moved to the  position, the indicator goes off.

When operating the PDW-R1 from an AC power supply, normally leave the AC power switch in the **I** position, and switch the PDW-R1 between the operating and standby states using the on/standby switch.

3 Remote control switch and NETWORK access indicator

Different positions of the switch allow different operations as follows.

NETWORK: Enables access to the network. The indicator lights when an external network device is being accessed. In this state, operation from the control panel is not possible.

LOCAL: Enables operation from the control panel.

REMOTE: Enables remote control of the PDW-R1 from a device connected to the **iS400** (i.LINK) connector or REMOTE connector on the side panel. Use extended menu item 214 “REMOTE INTERFACE” to select which of the connectors is used.

See 7-3-2 “Extended Menu Operations” (page 108) for more information about how to make extended menu settings.

4 KEY INHI (key inhibit) switch

Setting this switch to ON lights the KEY INHI indicator and disables the switches and buttons that are set to “dis” with extended menu item 118 “KEY INHIBIT.”

1 Time data settings section

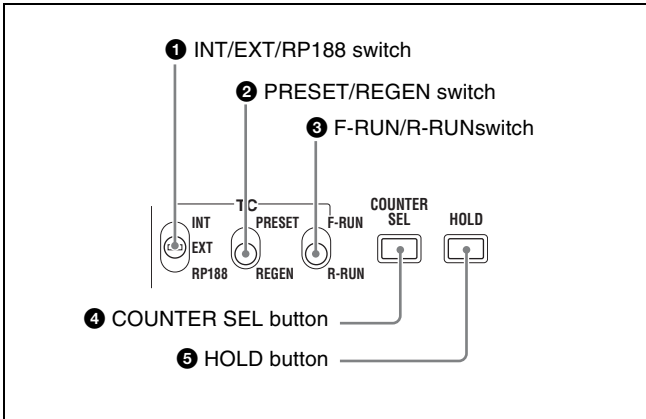

1 INT/EXT/RP188 (internal/external/RP188 selector) switch

Before recording time code, select the type of time code with this switch.

INT: Use time code generated internally by this unit.

EXT: Use time code input from an external source.

RP188: Use SMPTE RP188 LTC in an SDI signal.

2 PRESET/REGEN (regeneration) switch

This switch selects whether to preset a new time code value or follow already recorded time code.

PRESET: Record time code starting with a preset initial value.

REGEN: Record time code continuous with existing time code on the disc. Regardless of the setting of the F-RUN/R-RUN switch, the unit operates in R-RUN mode.

3 F-RUN/R-RUN (free run/recording run) switch

This switch selects the operating mode of the internal time code generator.

F-RUN: Time code advances regardless of the operating state of the unit. Use this setting to align the time code with real time or to synchronize the time code with external time code.

R-RUN: Time code advances only during recording. Use this setting to obtain consecutive time code on the disc.

For details, see 4-1-2 “Recording Time Code and User Bit Values” (page 44).

4 COUNTER SEL button

This cycles the data displayed in the time data display through the sequence TC, UB, and COUNTER.

TC: The playback time code read by the internal time code reader, or the time code generated by the internal time code generator.

Make the TC or VITC selection in extended menu item 629 “TC SELECT.”

UB: The user bits inserted in the playback time code, or user bits generated by the internal time code generator.

Make the UB or VIUB selection in extended menu item 629 “TC SELECT.”

COUNTER: The elapsed recording/playback time (hours, minutes, seconds, frames). This can be reset by pressing the RESET button (see page 14).

The corresponding indicator above the time data display lights according to the setting.

You can also synchronize timecode with the time of the internal clock. For details, see “To set time code to the time of the internal clock” (page 45).

5 HOLD button

Press this button to stop the time code generator.

Also, when setting the time code or user bits to be recorded, press this button first, to hold the values.

2 Operating mode selection/menu setting section

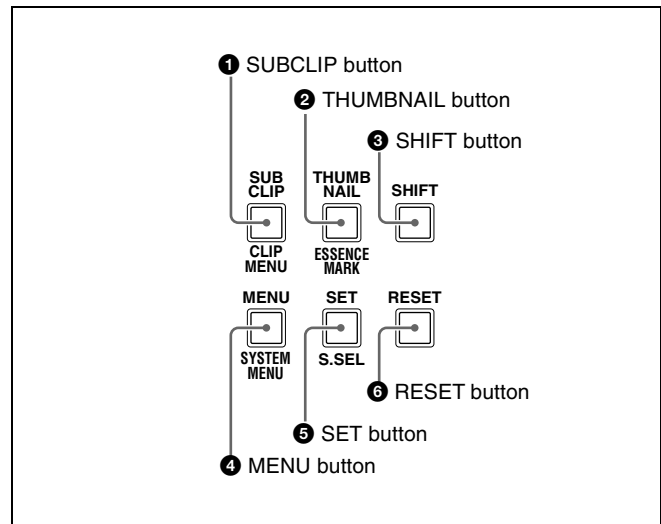

1 SUBCLIP button

To play back following a clip list, press this button, turning it on (see page 54). This is also effective for jog and shuttle operations.

To play clips in the order they are recorded, press this button again, turning it off.

The CLIP menu (see page 68) appears in the time data display, in the video panel, and on an external monitor when you press this button with the SHIFT button held down. Press the MENU button to escape from the CLIP menu.

Note

If no clip list is registered, this button does not light when pressed. The operation is invalid.

2 THUMBNAIL button

To carry out a thumbnail search or create a clip list, press this button turning it on. Thumbnail images representing

each clip or sub-clip appear. Press once more to turn the button off, and return to a whole-screen display. To display the thumbnails of essence mark frames (frames with an essence mark attached), hold down the SHIFT button, and press this button. The essence mark selection menu appears. Select the desired type of essence mark, and the corresponding essence mark frames appear in thumbnails. Press once more, turning the button off, to return to a whole-screen display.

3 SHIFT button

Use to switch the functions of various buttons.

4 MENU button

Use for setup menu and system menu operations. Pressing this button displays the setting of a setup menu item in the time data display. The same information is also superimposed on the displays of the video panel and a monitor connected to this unit (see page 94). Press once more to return to the original display. The system menu (see page 117) appears in the time data display, in the video panel, and on an external monitor, when you press this button with the SHIFT button held down. Press this button again to escape from the system menu.

5 SET button

Use for setup menu settings (see page 94), scene selection (thumbnail search) settings, and so on.

The scene selection window or a menu for sub clip operations appears when you press this button with the SHIFT button held down with either of the following displayed. The window or menu appears in the video panel, and on an external monitor.

When a thumbnail screen is displayed: The scene selection window (see page 62) appears.

When a sub clip thumbnail is displayed: A sub clip operation menu (see page 64) appears.

6 RESET button

Press to reset the counter. This is also used to cancel or abandon setup menu settings and scene selection (thumbnail search).

3 Jog/shuttle control block

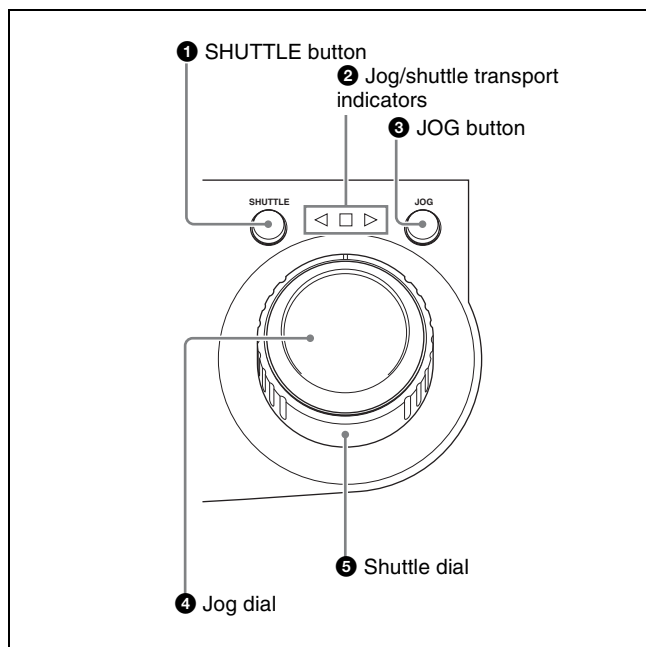

For details of playback operations with these buttons and dials, see 4-2-2 “Playback Operation” on page 51.

1 SHUTTLE button

To play back in shuttle mode using the shuttle dial, press this button, turning it on.

This button switches to shuttle mode whenever it is pressed, even during recording. If you do not want recording to stop with this button, set extended menu item 145 “MODE KEY ENABLE DURING RECORDING” to “stop.”

Pressing the JOG button or turning the jog dial switches to jog mode.

2 Jog/shuttle transport indicators

These show the playback direction in jog or shuttle speed mode.

- ◀ (green): Lights during playback in the reverse direction.
- ▶ (green): Lights during playback in the forward direction.
- (red): Lights during still image display.

3 JOG button

To play back in jog mode using the jog dial, press this button, turning it on.

This button switches to jog mode whenever it is pressed, even during recording. If you do not want recording to stop with this button, set extended menu item 145 “MODE KEY ENABLE DURING RECORDING” to “stop.”

Pressing the SHUTTLE button or turning the shuttle dial switches to shuttle mode.

4 Jog dial

Turn this for playback in jog mode. Turn clockwise for forward direction playback, and counterclockwise for reverse direction playback. In jog mode, the playback

speed varies in the range ± 1 times normal speed, according to the rotation rate of the jog dial. There are no detents. Normally, you press the JOG button before turning the jog dial, but it is also possible to make a setting to enable jog mode directly by turning the dial (set extended menu item 101 “SELECTION FOR SEARCH DIAL ENABLE” to “dial”).

5 Shuttle dial

Turn this for playback in shuttle mode. Turn clockwise for forward direction playback, and counterclockwise for reverse direction playback. In shuttle mode, the playback speed varies in the range ± 20 times normal speed (using MPEG IMX/DVCAM), according to the angular position of the shuttle dial. The shuttle dial has a detent at the center position, for still image playback.

Normally, you press the SHUTTLE button before turning the shuttle dial, but it is also possible to make a setting to enable shuttle mode directly by turning the dial (set extended menu item 101 “SELECTION FOR SEARCH DIAL ENABLE” to “dial”).

Note

When extended menu item 101 “SELECTION FOR SEARCH DIAL ENABLE” is set to “dial,” after using the shuttle dial, return it to the center position. If the shuttle dial is not in the center position, it is possible occasionally for vibration from other operations to activate the dial, and start playback in shuttle mode.

4 Audio settings section

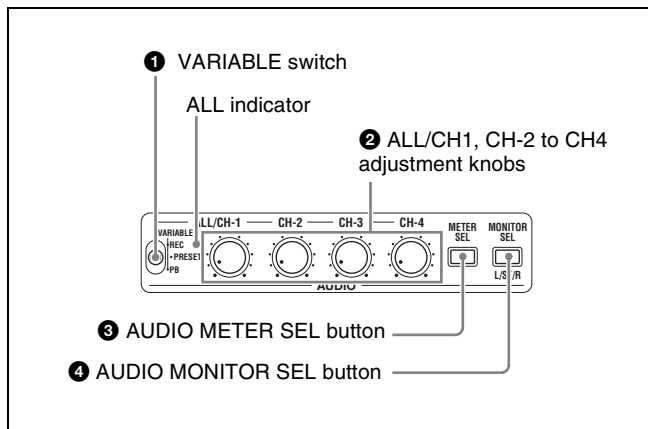

1 VARIABLE (audio level adjustment selector) switch

This selects which of the input audio and playback audio has the level adjusted by the ALL/CH-1, and CH-2 to CH-4 adjustment knobs.

REC: Adjust the input audio levels. The playback audio levels are fixed at their preset values.

PRESET: Do not adjust the audio levels.

PB: Adjust the playback audio levels. The input audio levels are fixed at their preset values.

2 ALL/CH-1, CH-2 to CH-4 (audio level) adjustment knobs

Depending on the setting of the VARIABLE switch, these adjust the input audio or playback audio levels of channels 1 to 4.

By the setting of extended menu item 131 “AUDIO VOLUME,” you can enable the ALL/CH-1 knob to simultaneously adjust all eight channels. When this simultaneous adjustment is enabled the ALL indicator lights.

3 AUDIO METER SEL (selection) button

When using MPEG IMX format in eight-channel mode, select whether the audio level meters should display channels 1 to 4 or channels 5 to 8.

Pressing this button toggles the selection, and the audio level meter channel display also changes.

The factory default is for channels 1 to 4 to be selected.

4 AUDIO MONITOR SEL (selection) button

This button selects two channels from among the up to eight audio signal channels. You can monitor the audio of the selected channels (the left and right channels in the case of stereo output) with the PHONES jack on the front panel and the built-in speaker.

Pressing this button cycles through the following five channel combinations.

- **tr1/2:** Channels 1 (left) and 2 (right)
- **tr3/4:** Channels 3 (left) and 4 (right)
- **tr5/6:** Channels 5 (left) and 6 (right)
- **tr7/8:** Channels 7 (left) and 8 (right)
- **MENU:** Audio channels selected with extended menu item 837 and 838 “AUDIO MONITOR CHANNEL ARRANGE”

The factory default is for channels 1 (left) and 2 (right) to be selected.

You can select whether to monitor both of the selected channels or only one, by pressing this button with the SHIFT button held down. Each press selects stereo, right, or left.

ST: Stereo audio is output from the PHONES jack.

Monaural audio, the left and right channels mixed, is output from the built-in speaker.

R: The right channel audio is output from the PHONES jack and the built-in speaker.

L: The left channel audio is output from the PHONES jack and the built-in speaker.

5 Recording and playback control section

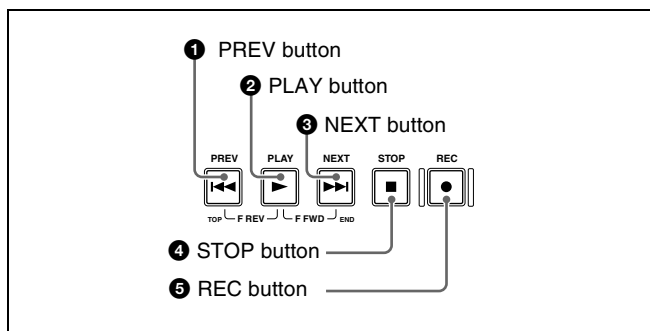

1 PREV (previous) button

Press this button, turning it on, to show the first frame of the current clip. While the first frame of a clip is shown, pressing this button jumps to the beginning of the previous clip.

This button is also used together with other buttons for the following operations.

Reverse direction high-speed search: Hold down the PLAY button, and press this button. A high-speed search in the reverse direction is carried out.

Displaying the first frame of the first clip: Hold down the SHIFT button, and press this button.

2 PLAY (playback) button

To start playback, press this button, turning it on. This button stops recording whenever it is pressed, even during recording. If you do not want recording to stop with this button, set extended menu item 145 “MODE KEY ENABLE DURING RECORDING” to “stop.”

3 NEXT button

Press this button, turning it on, to jump to the next clip, and show the first frame.

This button is also used together with other buttons for the following operations.

Forward direction high-speed search: Hold down the PLAY button, and press this button. A high-speed search in the forward direction is carried out.

Displaying the last frame of the last clip: Hold down the SHIFT button, and press this button.

4 STOP button

To stop recording or playback, press this button, turning it on. The frame at the stop point appears.

The unit enters standby off mode when you press this button with the SHIFT button held down. It returns from standby off mode to the original state when you press this button again with the SHIFT button held down. (The lit or unlit status of the STOP button does not change.)

This unit can automatically enter standby off mode whenever a specified time elapses in disc stop mode. For details, see the description of extended menu item 501 “STILL TIMER” (page 101).

5 REC (record) button

To start recording, hold down this button, and press the PLAY button. The recording takes place on an unrecorded part of the disc.

To stop recording, press the STOP button. This creates a clip of the recorded portion.

6 Arrow buttons

The four arrow buttons are also used as the MARK1 button, MARK2 button, IN button, and OUT button. The correspondence with the buttons is as follows.

⇧ **button:** MARK1 button

⇩ **button:** MARK2 button

⇐ **button:** IN button

⇒ **button:** OUT button

You can use these buttons for thumbnail selection, menu setting operations, setting IN/OUT points, and so on.

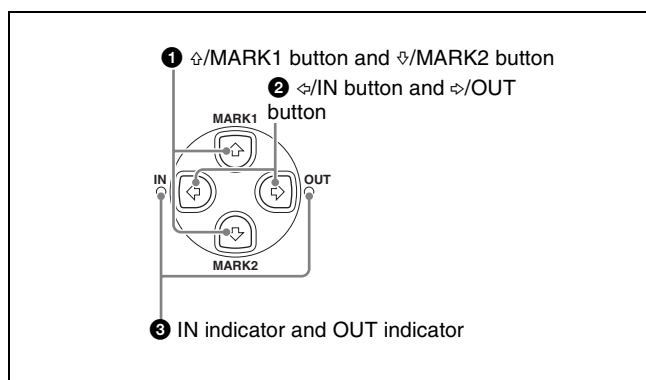

1 ⇧/MARK1 button and ⇩/MARK2 button

When the THUMBNAIL button (see page 13) is lit, you can use these for thumbnail selection.

During recording and playback, the ⇧/MARK1 and ⇩/MARK2 buttons can be pressed with the SET button held down to record a shot mark 1 or shot mark 2 as an essence mark.

To delete or change essence marks, use the supplied PDZ-1 Proxy Browsing Software.

2 ⇐/IN button and ⇒/OUT button

When the THUMBNAIL button (see page 13) is lit, you can use these for thumbnail selection.

An In or Out point is set when you press the SET button with the ⇐/IN or ⇒/OUT button held down. The In or Out point setting is deleted when you press the RESET button with the ⇐/IN or ⇒/OUT button held down.

3 IN indicator and OUT indicator

IN indicator: When an IN point is set, this lights.

If an attempt is made to set the IN point after a recorded OUT point, this flashes.

OUT indicator: When an OUT point is set, this lights.

If an attempt is made to set the OUT point before a recorded IN point, this flashes.

2-3 LCD Panel

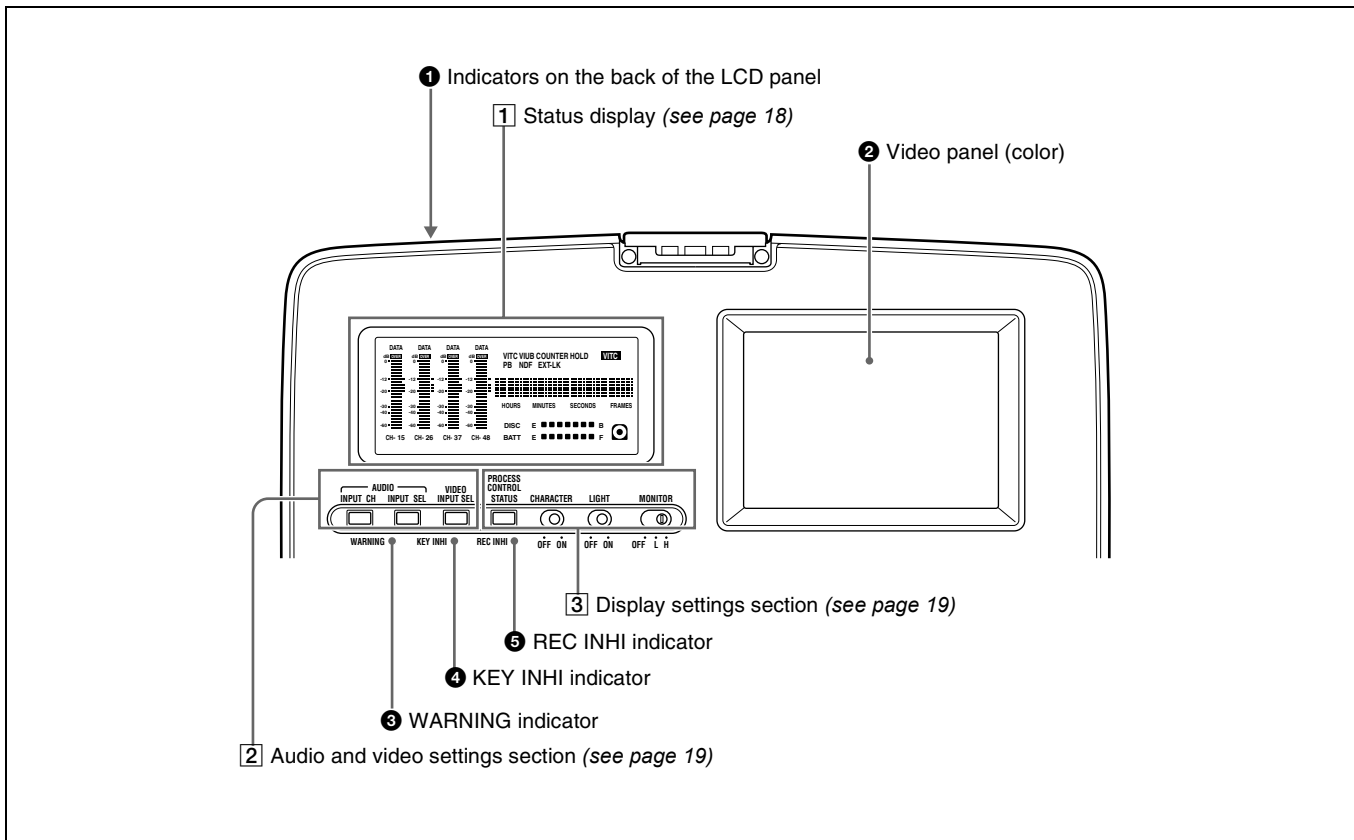

1 Indicators on the back of the LCD panel

There are two indicators, as follows.

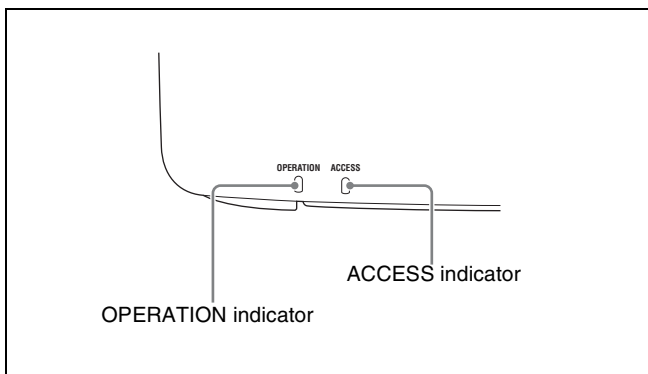

OPERATION indicator: Lights when the on/standby switch on the control panel is in the on (I) position.

ACCESS indicator: Lights when the disc is being accessed. If the on/standby switch is set to the  position while this indicator is lit, access to the disc is completed before the unit switches to the standby state.

Note

While the ACCESS indicator is lit, do not turn off the AC power switch, disconnect the power cord, or remove the battery. This could lead to a loss of data from the disc.

2 Video panel (color)

In recording, playback and editing operations, this shows recording and playback video, thumbnails, and other images. A status screen appears here when you press the STATUS button (see page 19).

3 WARNING indicator

This lights when condensation within the PDW-R1, a laser diode fault, or another hardware error is detected. It goes off when the error state is cleared. When this indicator is lit, the time data display and video panel show an error message.

For details, see 8-3 “Error Messages” (page 121) and 8-4 “Alarms” (page 122).

4 KEY INHI (key inhibit) indicator

This lights when the KEY INHI switch is set to on, with either “MON./INPUT SEL” or “CONTROL PANEL” set to “dis” in extended menu item 118 “KEY INHIBIT.”

5 REC INHI (recording inhibit) indicator

This lights in the following cases.

- When a disc with recording inhibited is loaded.
- When extended menu item 310 “REC INHIBIT” is set to “on.”
- The format of the recorded part of the disc does not match the settings of the PDW-R1 (number of recorded channels, TV system (525/625 selection), and recording format (DVCAM/IMX50/IMX40/IMX30 selection)).

1 Status display

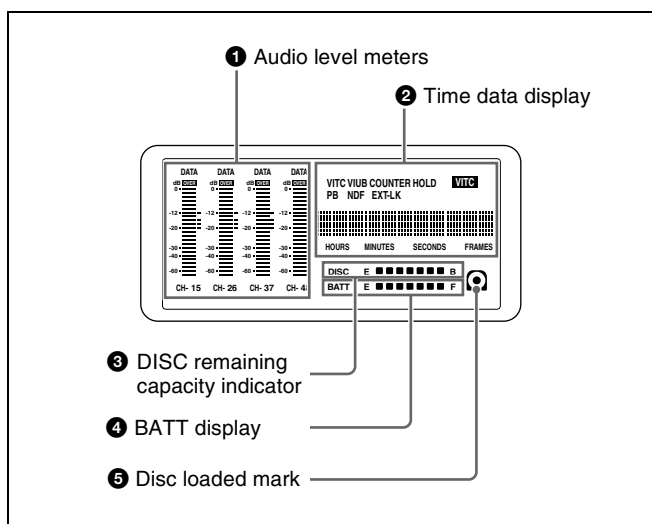

1 Audio level meters

Depending on the setting of the AUDIO METER SEL button (see page 15), these show the audio recording levels (during recording) or audio playback levels (during playback) of channels 1 to 4 or channels 5 to 8. If an audio level exceeds 0 dB, the OVER indicator lights.

The DATA indicator lights when non-audio signals are played back.

By means of a maintenance menu setting, you can display a reference level indicator (“-”) to the right of each meter when recording.

For details of the maintenance menu, see 7-4 “Maintenance Menu” on page 112.

2 Time data display

Normally, this shows the disc playback time, time code, or user bit information, as selected by the COUNTER SEL button (see page 13) and extended menu item 629 “TC SELECT.”

It is also used for error messages, setup menus, and other displays.

The following indicators are located above the time data display.

COUNTER indicator: This lights when a counter value (hours, minutes, seconds, and frames, resettable) is displayed in the time data display.

HOLD indicator: This lights when the internal time code generator (TCG) is stopped. Does not light when the output of the time code reader (TCR) is being displayed during playback and stop.

TC/VITC (time code type) indicator: This lights when the COUNTER SEL button (see page 13) is set to TC. The time data display shows the time code.

When extended menu item 629 “TC SELECT” is set to “tc,” this shows “TC,” and when “vitc” is selected, it shows “VITC.”

UB/VIUB (user bit type) indicator: This lights when the COUNTER SEL button is set to UB. The time data display shows the user bits.

When extended menu item 629 “TC SELECT” is set to “tc,” this shows “UB,” and when “vitc” is selected it shows “VIUB.”

VITC indicator: This lights in the following cases.

- In playback mode, when VITC is being read. (Regardless of what the time data display is showing.)
- When VITC is being recorded, or in E-E mode¹⁾ when VITC is recorded due to one of the following conditions.
 - Extended menu item 619 “VITC” is set to “on.”
 - There is VITC in the selected video input signal, and that line has been set to “thru” with extended menu item 723 “INPUT VIDEO BLANK.”

PB (playback) indicator: This lights when the output of the time code reader (TCR) is being displayed.

NDF (non-drop-frame) indicator: This lights in E-E mode when extended menu item 628 is set to “ndf,” and during playback when the clip on the disc has non-drop-frame time code.

EXT-LK (external synchronization) indicator: This lights when the internal time code generator is locked to an external signal input to the TC IN connector.

1) E-E mode: Abbreviation of Electric to Electric mode. The mode in which input video and audio signals are output after passing only through the electrical circuits.

3 DISC remaining capacity indicator

This shows the amount of free capacity on the current disc, as follows.

■■■■■■■■ (7 segments lit): All capacity is available. As clips are recorded, the number of lit LED segments decreases.

“DISC” flashing: The disc is almost full.

“DISC” and “E” flashing: The disc is full (it must be replaced).

4 BATT (battery) status display

This shows the amount of charge left in the battery, as follows.

■■■■■■■■ (7 segments lit): Adequately charged. As the battery discharges, the number of lit LED segments decreases.

“BATT” flashing: Almost exhausted. Operation of the PDW-R1 continues.

“**BATT**” and “**E**” flashing: Exhausted (charging required). Operation of the PDW-R1 stops.

5 Disc loaded mark

This lights while a disc is loaded in the PDW-R1. It flashes as the disc is inserted, and while it is being ejected.

2 Audio and video settings section

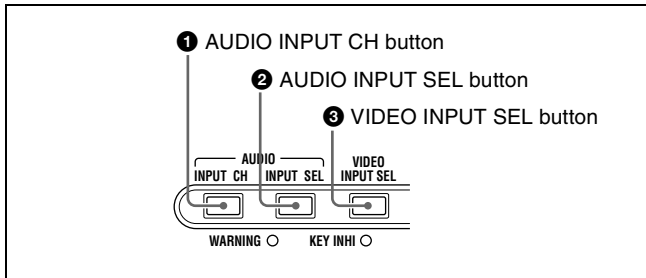

1 AUDIO INPUT CH (channel) button

This selects the channel to which the audio input signal selection applies.

Each press of this button selects the next audio input channel, in the following order.

CH1 → CH2 → CH3 → CH4

The selected channel appears in the time data display and video panel.

You can use the AUDIO INPUT SEL button to select the audio input signal for the selected channel.

When audio is in eight-channel mode

On channels 5 to 8, you can input only the audio signals embedded in an SDI signal.

2 AUDIO INPUT SEL (selection) button

This selects the input signal to the channel selected with the AUDIO INPUT CH button described above.

Each press of this button selects the next audio input signal, and the audio input indications in the time data display and video panel change to reflect this.

ANALOG: Analog audio signal input to the AUDIO IN connector

SDI: SDI audio signal input to the SDI IN connector

AES/EBU: AES/EBU format digital audio signal input to the DIGITAL AUDIO (AES/EBU) IN connector

SG: Audio test signal generated by the internal signal generator

3 VIDEO INPUT SEL (selection) button

Pressing this button cycles through the following selections of the video input signal.

- SDI video signal input to the SDI IN connector
- Composite video signal input to the VIDEO IN connector
- Test video signal from the internal signal generator
- i.LINK-compliant DVCAM format digital signal (i.LINK input comprising both video and audio signals) input to the iS400 (i.LINK) connector

Signals are selected in the following order. The video input indication in the video panel changes to reflect this.

SDI → COMPOSITE → SG → i.LINK

Note

Input signals (AV/C) from the iS400 (i.LINK) connector cannot be recorded when the basic menu item 031 “RECORDING FORMAT” is set to “IMX 50,” “IMX40,” or “IMX 30.” E-E video display and audio output are also not possible.

Select a signal other than “i.LINK” to record IMX format video signals. When i.LINK input signals are selected, set basic menu item 031 “RECORDING FORMAT” to “DVCAM.”

See 7-2-2 “Basic Menu Operations” (page 94) for more information about how to make basic menu settings.

3 Display settings section

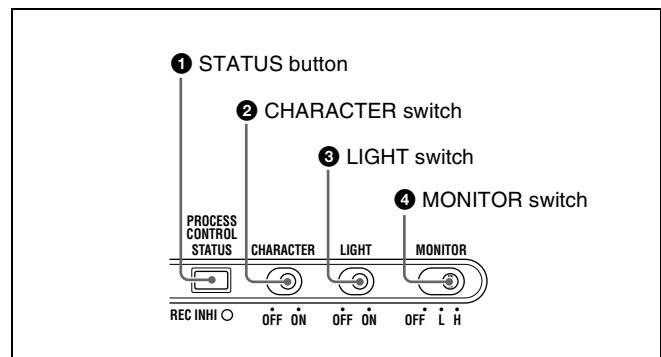

1 STATUS button

Displays information about the current settings of this unit in the video panel.

The displayed information changes in the following order with each press of the button.

Page 1 → Page 2 → Display off

Items displayed on page 1

Item	Description
525, 625	Line mode selected with basic menu item 013
IMX50, IMX40, IMX30, DVCAM	Video recording format selected with basic menu item 031
8ch, 4ch	Number of audio recording channels (When the format is IMX50/40/30, this is the number of channels specified by maintenance menu item “AUDIO CONFIG” - “DATA LENGTH.” When the format is DVCAM, this is always 4ch.)
VIN	The video input signal selected with the VIDEO INPUT SEL button (setting values: SDI, COMPST, SG, i.LINK)
AINn (n: channel number 1 to 4)	The audio input signal selected with the AUDIO INPUT SEL button (setting values: SDI, AES/EBU, SG, ANALOG)



Item	Description
PROC	This appears when at least 1 video processing parameter has been set to "VAR (VARIABLE)."
DISC ^{a)}	The line mode of the current clip on the disc (setting values: 525, 625), the video recording format (setting values: IMX50, IMX40, IMX30, DVCAM), and the number of audio recording channels (setting values: 8ch, 4ch)
RMT	When the remote control switch is set to REMOTE, the control interface selected with extended menu item 214 (setting values: 9PIN, i.LINK, — — —) ^{b)}
PARA	This appears when the parallel recording with camcorder function is enabled.
AC IN DC IN ???.?V BATT ??% (???.?V)	The type of power supplied to this unit (AC IN: AC power, DC IN: DC power, BATT: battery pack). The voltage (units: V) appears when DC power is used, and the remaining battery charge (unit: % or V) appears when the battery pack is used.
??MIN	Free capacity remaining on disc (unit: minutes)
???	Playback order number of clip being played back
??h??m??s??	Duration of clip being played back

a) This appears when a disc is loaded, and the format of a clip recorded on the disc is different from the format specified by basic menu item 031 or the setting of the "AUDIO CONFIG" - "DATA LENGTH" item in the maintenance menu.

b) 9PIN: When extended menu item 214 is set to "9PIN"
i.LINK: When extended menu item 214 is set to "i.LINK" and menu item 215 is set to "AV/C"
— — —: When extended menu item 214 is set to "i.LINK" and menu item 215 is set to "FAM" (remote control from a device connected to the  S400 (i.LINK) connector is not possible when this combination of settings is in force)

Items displayed on page 2

Item	Description
VIDEO INPUT	Same as VIN on page 1
AUDIO INPUT n (n: channel number 1 to 4)	Same as AINn on page 1
AUDIO OUTPUT	
MONITOR L/R	Audio channels selected with AUDIO MONITOR SEL button (setting values: tr1/2, tr3/4, tr5/6, tr7/8, MENU)
(MONITOR) L/ST/R	Monitor channel selected with SHIFT + AUDIO MONITOR SEL button (setting values: STEREO, R, L)
ANALOG 1/2	Audio channels (setting values: tr1/2, tr3/4, tr5/6, tr7/8) assigned to the AUDIO OUT 1/3, 2/4 connectors with extended menu item 824

Item	Description
AES/EBU 1/2	Audio channels (setting values: tr1/2, tr3/4, tr5/6, tr7/8) assigned to the DIGITAL AUDIO (AES/EBU) OUT 1/2 connectors with sub item 1 of extended menu item 827
(AES/EBU) 3/4	Audio channels (setting values: tr1/2, tr3/4, tr5/6, tr7/8) assigned to the DIGITAL AUDIO (AES/EBU) OUT 3/4 connectors with sub item 2 of extended menu item 827
SDI/DV 1/2	Audio channels (setting values: tr1/2, tr3/4, tr5/6, tr7/8) assigned to channels 1 and 2 of the SDI OUT (SUPER) and  S400 (i.LINK) connectors with sub item 1 of extended menu item 828
(SDI/DV) 3/4	Audio channels (setting values: tr1/2, tr3/4, tr5/6, tr7/8) assigned to channels 3 and 4 of the SDI OUT (SUPER) and  S400 (i.LINK) connectors with sub item 2 of extended menu item 828

When you press this button with the SHIFT button held down, the process control screen appears in the video panel. You can use this screen to adjust the following parameters.

- Video output level
- Chroma output level
- Setup/black level
- Chroma phase
- Output signal sync phase
- Output signal subcarrier phase

See "Adjusting video processing parameters" (page 49) for more information about how to make the adjustments.

2 CHARACTER switch

Selects whether or not to superimpose the time code, menu settings, alarm messages, or other text information on the video signals output from the side panel SDI OUT (SUPER) and VIDEO OUT 2 (SUPER) connectors and also on the unit's video panel.

ON: Superimpose character information.

OFF: Do not superimpose character information.
The factory default setting is ON.

3 LIGHT switch

Selects whether the status display backlight is on or off.

ON: On.

OFF: Off.

The factory default setting is ON.

4 MONITOR switch

Selects whether to display video in the video panel.

H: Display with high brightness.

L: Display with low brightness.

OFF: Do not display.

The factory default setting is H.

2-4 Connectors

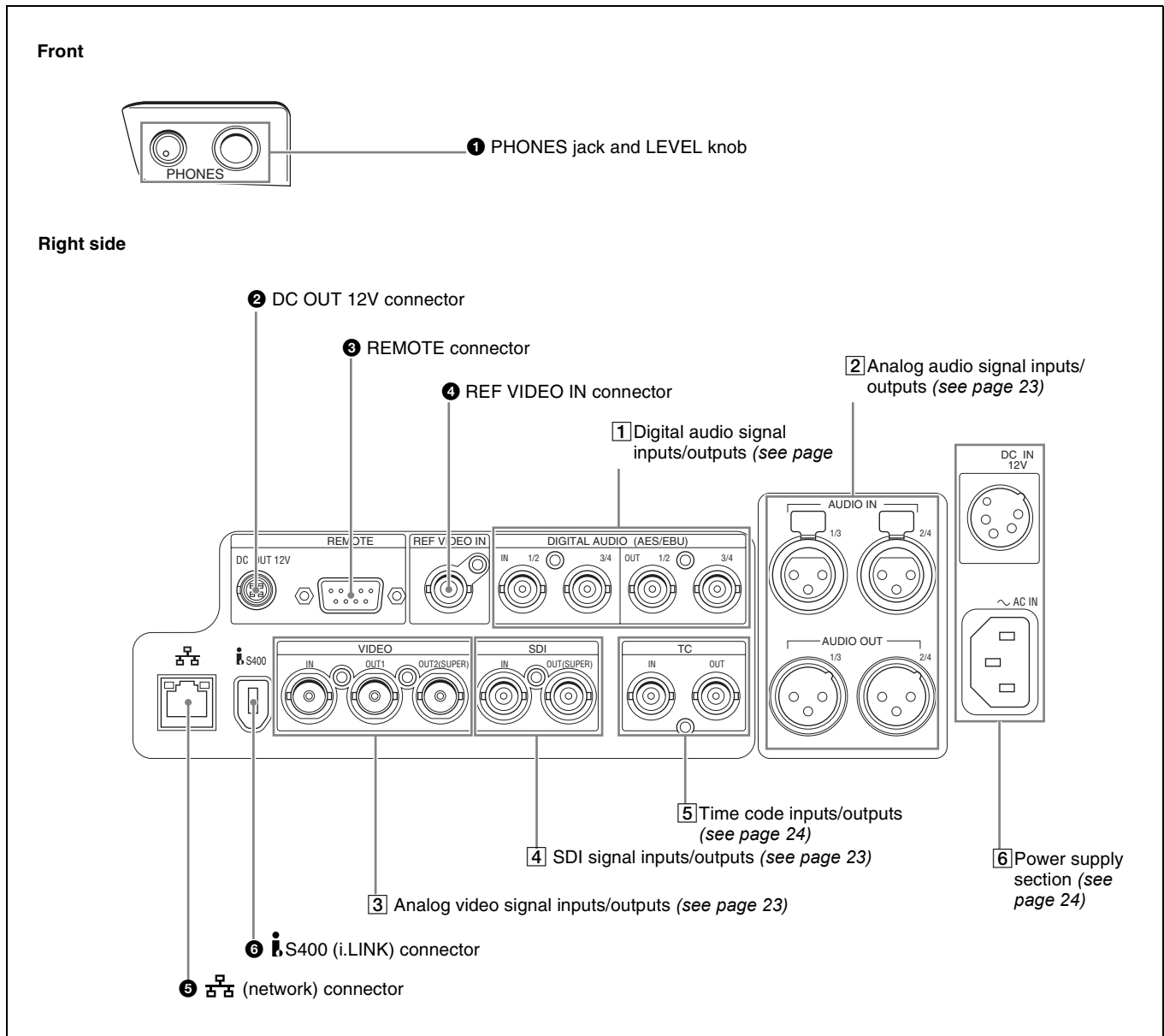

1 PHONES jack and LEVEL knob

The jack is a standard stereo jack. Connect stereo headphones with an impedance of 8 ohms, to monitor the audio during playback. (Non-audio signals are muted.) The channels monitored are selected by the AUDIO MONITOR SEL button.

Adjust the volume with the LEVEL knob. When extended menu item 820 “AUDIO OUTPUT CH1/CH2 SELECT” is set to “moni,” you can also cause this to simultaneously adjust the output volume from the AUDIO OUT 1/3 and 2/4 connectors on the side panel. To do this, in the setup menu, set extended menu item 114 “AUDIO MONITOR OUTPUT LEVEL” to “var.”

When no headphones are connected, you can listen to audio through the built-in speaker (monaural).

2 DC OUT (DC power output) 12V connector (4-pin, female)

Supplies power to the BVR-3 Remote Control Unit (not supplied) and the RM-280 Editing Controller (not supplied). (Max. 5 W)

Note

Do not connect to any external device except those listed above.

3 REMOTE (remote control signal) connector (D-sub 9-pin)

To control the PDW-R1 from a controller or VTR supporting the RS-422A Sony 9-pin VTR protocol, connect the device to this connector.

4 REF VIDEO IN (reference video signal input) connector (BNC type)

Input a reference video signal.

5 (network) connector (RJ-45 type)

This is a 10Base-T/100Base-TX connector for network connection.

To transfer files between an external device and the PDW-R1, connect a network cable to this connector and the external device.

Caution

For safety, do not connect the connector for peripheral device wiring that might have excessive voltage to this port. Follow the instructions in this manual when making connections.

ATTENTION

Par mesure de sécurité, ne raccordez pas le connecteur pour le câblage de périphériques pouvant avoir une tension excessive à ce port. Suivez les instructions pour ce port.

ACHTUNG

Aus Sicherheitsgründen nicht mit einem Peripheriegerät-Anschluss verbinden, der zu starke Spannung für diese Buchse haben könnte. Folgen Sie den Anweisungen für diese Buchse.

6 (i.LINK) connector (6-pin, IEEE1394 compliant)

Connect a DV device, computer, or similar, using an i.LINK cable. To prevent the connector from coming loose, we recommend that you secure the cable in the cable clamp as shown in the following figure.

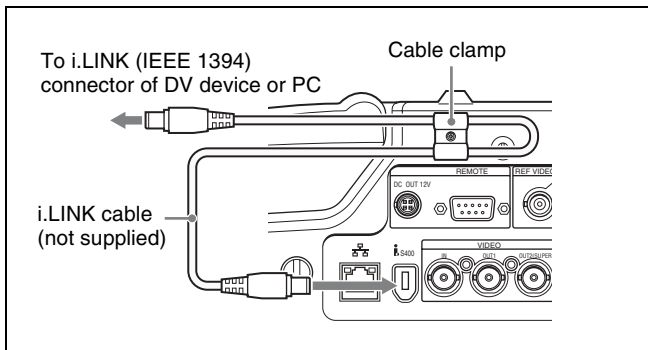

When the unit is shipped from the factory, the audio output signal is set to 16 bit/48 kHz/2ch mode. You can change the audio mode and output channel settings with extended

menu item 831 “DV OUT AUDIO MODE” and extended menu item 828 “SDI/DV AUDIO OUTPUT SELECT.”

See 7-3-2 “Extended Menu Operations” (page 108) for more information about how to make these settings.

Notes

- If video or audio signals from an external device connected with the  S400 (i.LINK) connector are not output, disconnect the i.LINK cable and connect it again, pushing it straight in.
- When the PDW-R1 is connected to a device with a 6-pin i.LINK connector by an i.LINK cable, before unplugging the i.LINK cable, first power off the device and disconnect the power plug from the outlet. If the i.LINK cable is unplugged with the device power plug still connected, a current from an excessive voltage (8 to 40 V) output from the i.LINK connector of the device flows into the PDW-R1. This may cause a failure of the PDW-R1.
- When connecting the PDW-R1 to a device with a 6-pin i.LINK connector, connect to the 6-pin i.LINK connector of the other device first.
- Except in playback mode (jog and shuttle modes, etc.), if you are monitoring the audio signal output from this connector on another device, the audio signal may sound differently from the audio signal played back on the PDW-R1.

1 Digital audio signal inputs/outputs

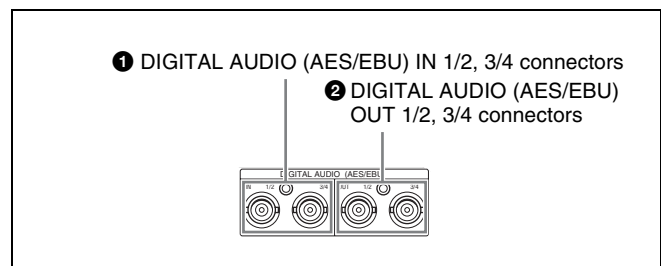

1 DIGITAL AUDIO (AES/EBU) IN (digital audio input) 1/2, 3/4 connectors (BNC type)

These input AES/EBU format digital audio signals. The left connector (1/2) corresponds to audio channels 1 and 2, and the right connector (3/4) corresponds to audio channels 3 and 4.

2 DIGITAL AUDIO (AES/EBU) OUT (digital audio output) 1/2, 3/4 connectors (BNC type)

These output AES/EBU format digital audio signals. When the unit is shipped from the factory, the 1/2 connector is set to audio channel 1/2, and the 3/4 connector is set to audio channel 3/4. You can change these settings with extended menu item 827 “AES/EBU AUDIO OUTPUT SELECT.”

To treat the input and output signals of these connectors as non-audio signals, set the maintenance menu item “AUDIO CONFIG”-“NON-AUDIO INPUT” (recording) and extended menu item 823 “NON-AUDIO FLAG PB” (playback).

See 7-3-2 “Extended Menu Operations” (page 108) for more information about how to make extended menu settings.

See 7-4-2 “Maintenance Menu Operations” (page 114) for more information about how to make maintenance menu settings.

2 Analog audio signal inputs/outputs

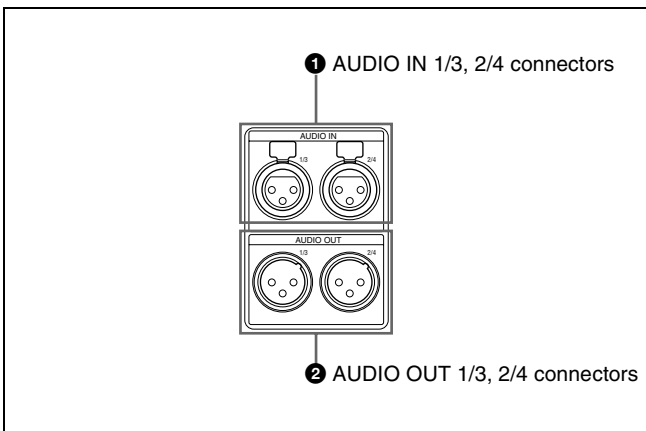

1 AUDIO IN (analog audio signal input) 1/3, 2/4 connectors (XLR 3-pin, female)

These input analog audio signals. With the AUDIO INPUT SEL button (see page 19), you can select whether the signal input to connector 1/3 is assigned to audio channel 1 or 3, and whether the signal input to connector 2/4 is assigned to audio channel 2 or 4. You can set the reference input level with the maintenance menu item “AUDIO CONFIG.” (Factory default setting: +4 dB)

For details of the maintenance menu, see 7-4 “Maintenance Menu” on page 112.

2 AUDIO OUT (analog audio signal output) 1/3, 2/4 connectors (XLR 3-pin, male)

These output analog audio signals. When the unit is shipped from the factory, the 1/3 connector is set to audio channel 1, and the 2/4 connector is set to audio channel 2. You can change these settings with extended menu item 824 “ANALOG LINE OUTPUT SELECT.”

You can set the output level with the maintenance menu item “AUDIO CONFIG.” (Factory default setting: +4 dB) Non-audio signals are muted.

You can also output audio monitor signals by setting extended menu item 820 “AUDIO OUTPUT CH1/CH2 SELECT” to “moni.”

See 7-3-2 “Extended Menu Operations” (page 108) for more information about how to make these settings.

For details of the maintenance menu, see 7-4 “Maintenance Menu” on page 112.

3 Analog video signal inputs/outputs

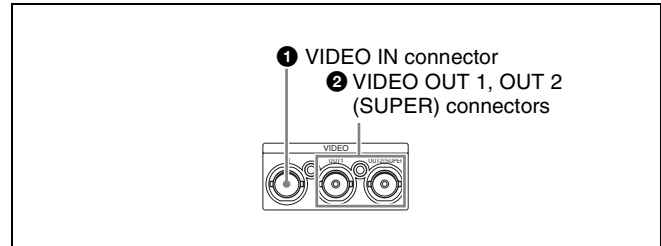

1 VIDEO IN (analog video input) connector (BNC type)

This inputs a composite video signal.

2 VIDEO OUT 1, OUT 2 (SUPER) (analog video output 1, output 2 (superimpose)) connector (BNC type)

These output composite video signals.

The output from the VIDEO OUT 2 (SUPER) connector can have time code, menu settings, alarm messages, and other text information superimposed.

4 SDI signal inputs/outputs

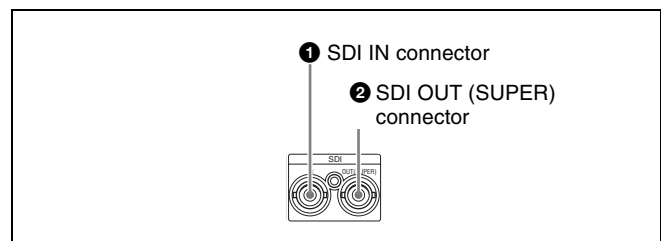

1 SDI IN (SDI signal input) connector (BNC type)

This inputs an SDI format video/audio signal.

2 SDI OUT (SUPER) (SDI signal output (superimpose)) connector (BNC type)

This outputs an SDI format video/audio signal.

When the unit is shipped from the factory, audio signal output is 8 channels with no switching, and RP188 time code output is set to on. You can change these settings with extended menu item 828 “SDI/DV AUDIO OUTPUT SELECT” and extended menu item 920 “SD-SDI H-ANC CONTROL.”

The output can have time code, menu settings, alarm messages, and other text information superimposed. To turn superimposition off, set the maintenance menu item “OTHERS”-“SDI SUPER” to “OFF.”

To treat the input and output signals of these connectors as non-audio signals, set the maintenance menu item

“AUDIO CONFIG”-“NON-AUDIO INPUT” (recording) and extended menu item 823 “NON-AUDIO FLAG PB” (playback).

See 7-3-2 “Extended Menu Operations” (page 108) for more information about how to make extended menu settings.

See 7-4-2 “Maintenance Menu Operations” (page 114) for more information about how to make maintenance menu settings.

5 Time code inputs/outputs

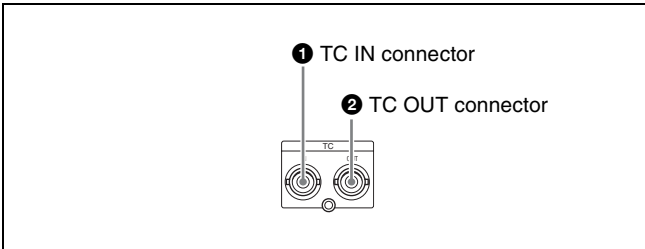

1 TC IN connector (BNC type)

This inputs an SMPTE time code generated by an external device.

2 TC OUT connector (BNC type)

This outputs the following time code, depending on the operating state of the PDW-R1.

During playback: playback time code

During recording: the time code from the internal time code generator or the time code input to the TC IN connector.

When extended menu item 611 “TC OUTPUT PHASE IN EE MODE” is set to “muting,” no time code is output.

6 Power supply section

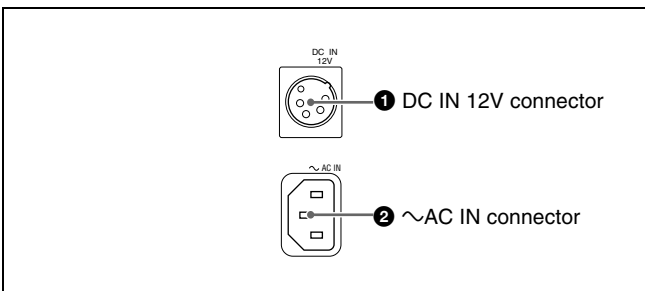

1 DC IN (DC power input) 12V connector (XLR type, 4-pin, male)

Connect DC power to this connector.

2 ~AC IN (AC power input) connector

Connect to an AC power supply, using an optional power cord (see page 133).

3-1 Connections and Settings

Note

Production of some of the peripherals and related devices described in this chapter has been discontinued. For advice about choosing devices, please contact your Sony dealer or a Sony sales representative.

3-1-1 Connecting an External Monitor

Connecting a Sony LCD monitor to the VIDEO OUT 1, VIDEO OUT 2 (SUPER), or SDI OUT (SUPER) connector of this unit enables you to see the output video on the monitor screen.

To superimpose text information, for example, time code and alarm messages, use the VIDEO OUT 2 (SUPER) or SDI OUT (SUPER) connector. You can select the kind of text information to display using basic menu item 005 “DISPLAY INFORMATION SELECT.”

For detailed information about basic menu items and how to make menu settings, see 7-2 “Basic Setup Menu” on page 90.

Connect a video monitor as example ① or ② shown in the following figure.

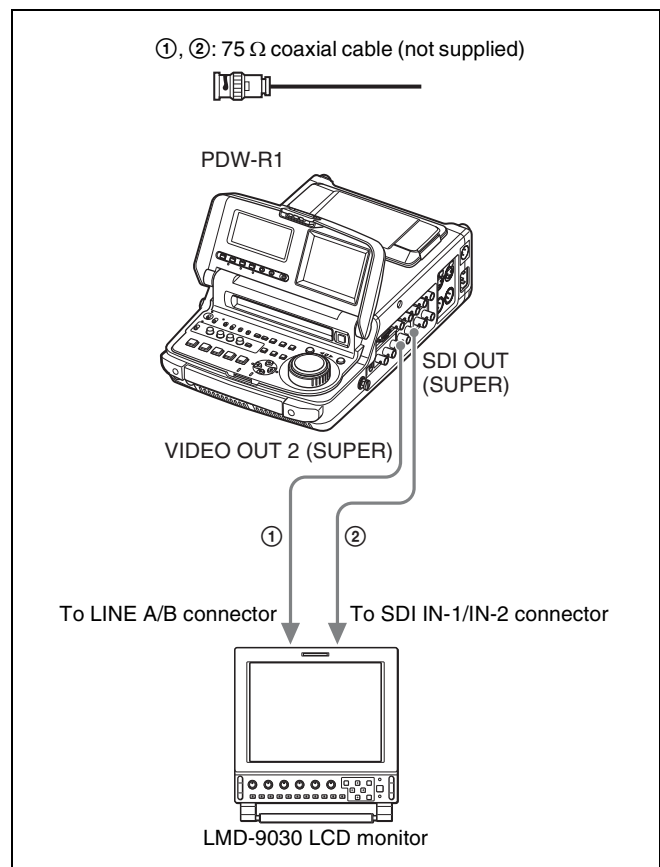

3-1-2 Connections for Using PDZ-1 Proxy Browsing Software

Using the supplied PDZ-1 Proxy Browsing Software, you can carry out simple editing with proxy AV data.

For an overview of PDZ-1 and how to install the software, see 5-4 “Using PDZ-1 Proxy Browsing Software” on page

For information about how to use the software, refer to the Help provided in the software.

Using the (network) connector (FTP connection)

The following shows an example of an FTP (File Transfer Protocol) connection.

Note

To use PDZ-1 requires the PDW-R1 IP address and other network-related settings to be made beforehand.

For details of the network-related settings, see “To change network settings” (page 115).

Connecting this unit directly to a laptop computer

①: Network cable (not supplied) ^{a)}

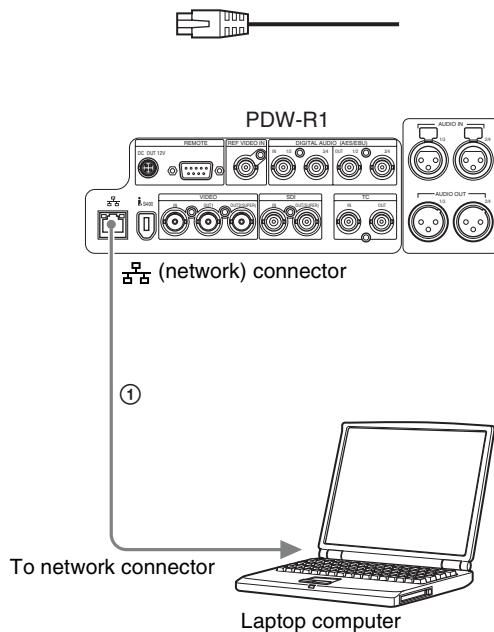

Make sure the remote control switch (see page 12) is set to “NETWORK” and extended menu item 257 “NETWORK ENABLE” is set to “net.”

a) Use a cross cable.

Connecting three PDW-R1 units to a laptop computer via a LAN.

①: Network cable (not supplied) ^{a)}

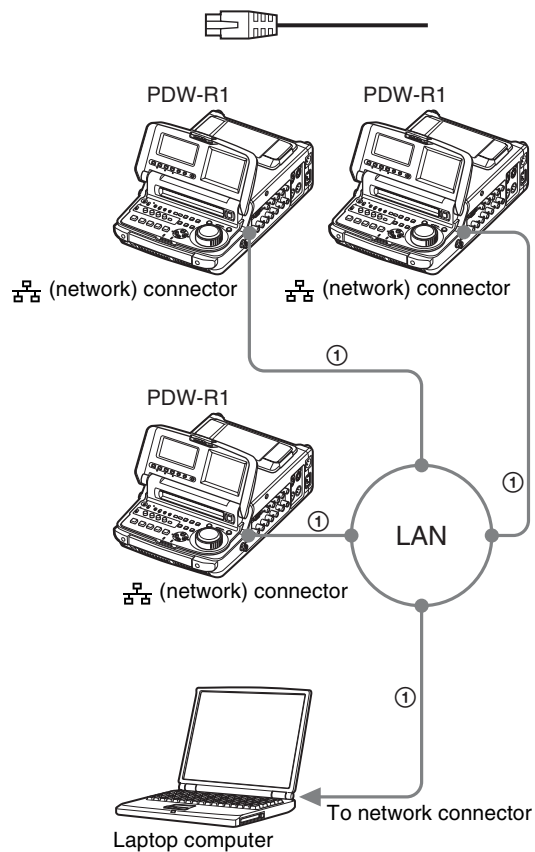

Make sure the remote control switch (see page 12) is set to “NETWORK” on each of the three PDW-R1 units and extended menu item 257 “NETWORK ENABLE” is set to “net.”

a) Use a straight cable.

Using the S400 (i.LINK) connector (FAM connection)

The following shows an example of a FAM (file access mode) connection.

Note

The PDZ-1 Proxy Browsing Software must be installed in advance.

The required FAM driver is also installed when you install the PDZ-1 software.

See 5-4 “Using PDZ-1 Proxy Browsing Software” (page 71) for more information about installing the PDZ-1 software.

Some limitations apply to FAM connections. For details, see 6-2 “File Access Mode File Operations” (page 78).

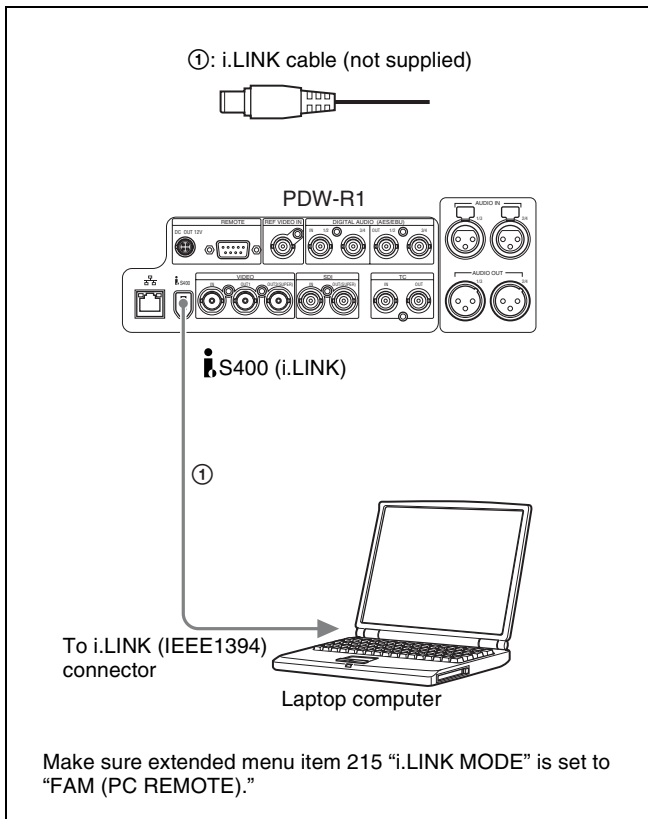

3-1-3 Connecting to a Nonlinear Editing System

You can send video/audio signals (AV/C data) from this unit to a nonlinear editing system connected to the i.S400 (i.LINK) connector. The following figure shows an example connection.

Notes

- The i.S400 (i.LINK) connector of this unit outputs video/audio signals in DVCAM format. Data recorded in MPEG IMX format is output after being converted into DVCAM format.
- The nonlinear editing system to be used being connected to this unit requires editing software (not supplied) supporting DVCAM format.

- Make the following settings before transferring video/audio signals (AV/C data) from this unit to a nonlinear editing system.

Audio mode selection

Use extended menu item 831 "DV OUT AUDIO MODE" to select either of the following.

4ch: 12 bit/32 kHz/4ch

2ch: 16 bit/48 kHz/2ch (Factory default setting)

Audio output channel selection

Select the audio output channels with extended menu item 828 "SDI/DV AUDIO OUTPUT SELECT."

For information about how to make extended menu item settings, see 7-3-2 "Extended Menu Operations" on page 108.

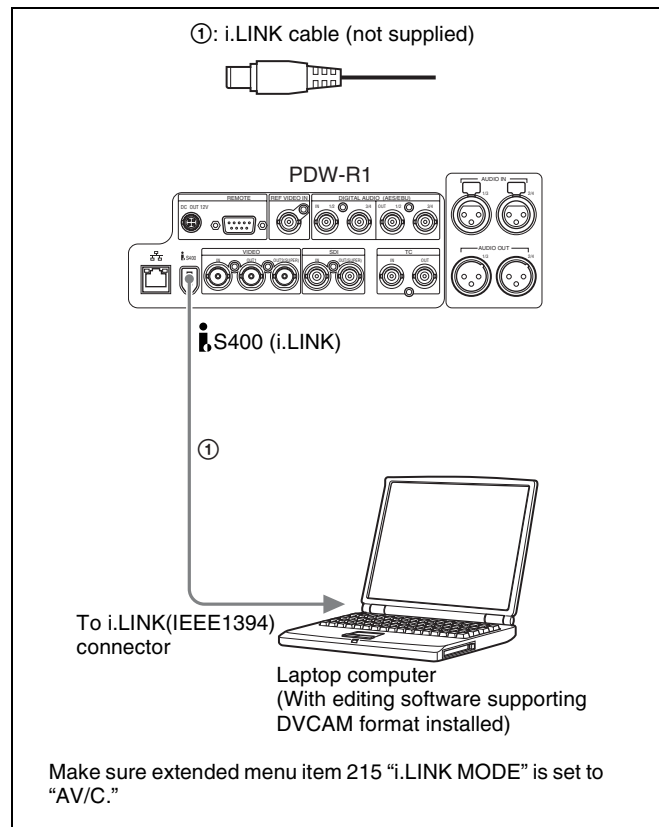

For the method of transferring video/audio signals (AV/C data) to a nonlinear editing system, refer to the manual provided with the editing software to be used.

3-1-4 Connections for Recording in Parallel With a Camcorder

You can start and stop recording on this unit at the same time that recording starts and stops on a camcorder. This allows you to make a backup recording of the video and audio shot by the camcorder. The following figure shows an example of the connections to make.

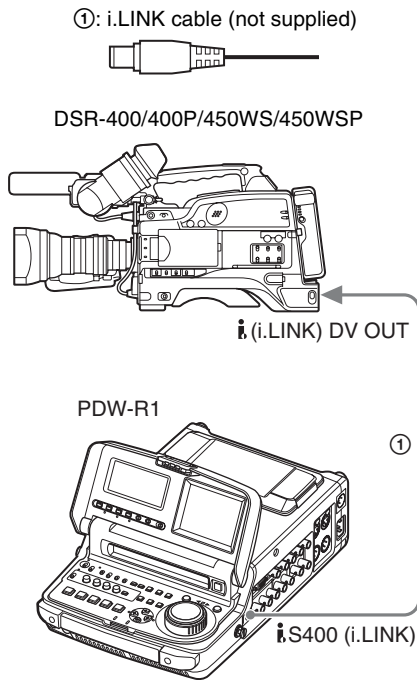

DSR-400/400P/450WS/450WSP settings

REC TRIGGER switch: INT ONLY
 "REC FORMAT" on the VTR MODE page of the
 MAINTENANCE menu: DVCAM

PDW-R1 settings

Remote control switch (*see page 12*): REMOTE
 VIDEO INPUT SEL button (*see page 19*): select i.LINK
 Basic menu item 031 "RECORDING FORMAT": DVCAM
 Extended menu item 214 "REMOTE INTERFACE": i.LINK
 Extended menu item 215 "i.LINK MODE": AV/C
 Extended menu item 216 "PARALLEL RECORDING MODE":
 on

3-1-5 Connections for Cut Editing

By connecting this unit to a VTR (for example, MSW-M2000/M2000P or DSR-2000/2000P) and an editing control unit, you can make up a cut editing system. Some example connections are shown in the following.

When making the connections, also refer to the manuals provided with the equipment to be connected. See page 32 for more information about editing control unit settings.

When using an editing control unit

Cut editing system comprising this unit as a player, an MSW-M2000/M2000P unit as a recorder, and a BVE-700 editing control unit.

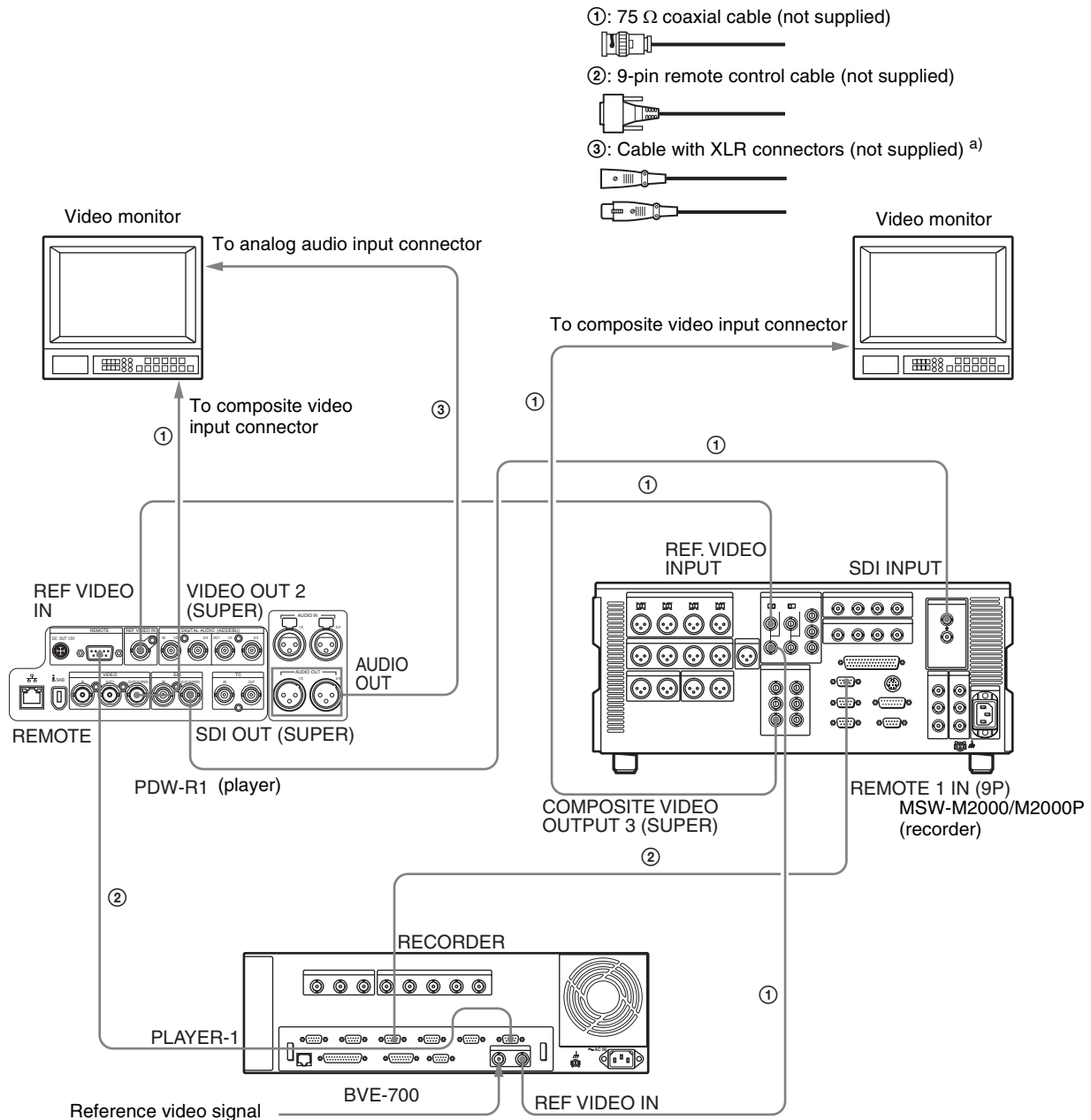

PDW-R1 (player) settings

Remote control switch (see page 12): REMOTE
 Extended menu item 214 "REMOTE INTERFACE": 9PIN
 Extended menu item 820 "AUDIO OUTPUT CH1/CH2 SELECT":
 moni

MSW-M2000/M2000P (recorder) settings

REMOTE 1(9P) button: Lit

For details about the settings of the MSW-M2000/M2000P, refer to the operation manual for the unit.

a) Use an XLR/pin converter plug (not supplied) as required.

When using the editing functions of the recorder

Connections using the REMOTE connector (D-sub 9-pin):
 Cut editing system comprising this unit as a player and an MSW-M2000/M2000P unit as a recorder. For cut editing, the system uses the editing functions of the recorder.

- ①: 75 Ω coaxial cable (not supplied)
- ②: 9-pin remote control cable (not supplied)
- ③: Cable with XLR connectors (not supplied) ^{a)}

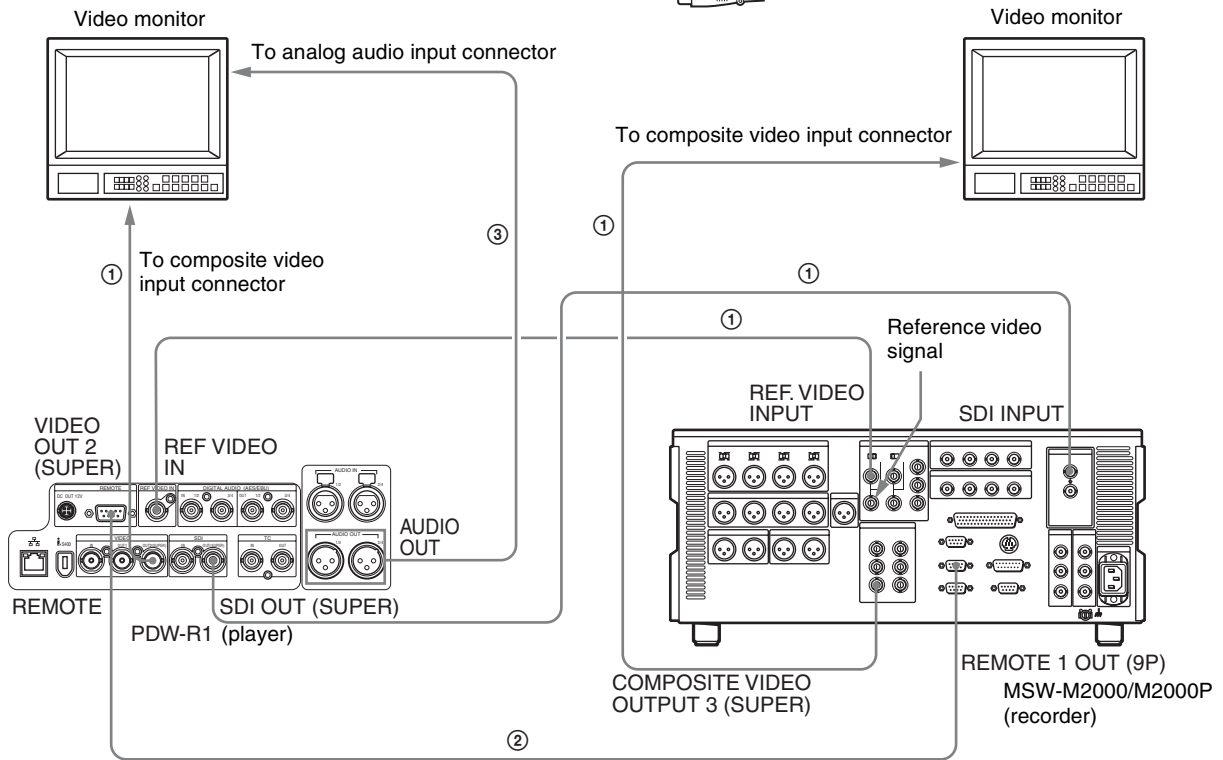

PDW-R1 (player) settings

Remote control switch (see page 12): REMOTE
 Extended menu item 214 "REMOTE INTERFACE": 9PIN
 Extended menu item 820 "AUDIO OUTPUT CH1/CH2 SELECT":
 moni

a) Use an XLR/pin converter plug (not supplied) as required.

MSW-M2000/M2000P (recorder) settings

REMOTE 1(9P) button: Unlit

For details about the settings of the MSW-M2000/M2000P, refer to the operation manual for the unit.

Connections using the i.S400 (i.LINK) connector:

Cut editing system comprising this unit as a player and a DSR-2000/2000P unit as a recorder. For cut editing, the system uses the editing functions of the recorder. In this system, all signals such as the video/audio signals and control signals are transferred through the i.S400 (i.LINK) connector.

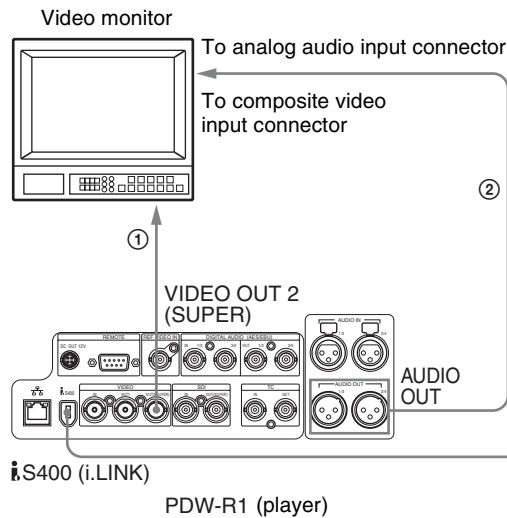
**PDW-R1 (player) settings**

Remote control switch (see page 12): REMOTE
 Extended menu item 214 "REMOTE INTERFACE": i.LINK
 Extended menu item 820 "AUDIO OUTPUT CH1/CH2 SELECT":
 moni

a) Use an XLR/pin converter plug (not supplied) as required.

①: 75 Ω coaxial cable (not supplied)



②: Cable with XLR connectors (not supplied) ^{a)}

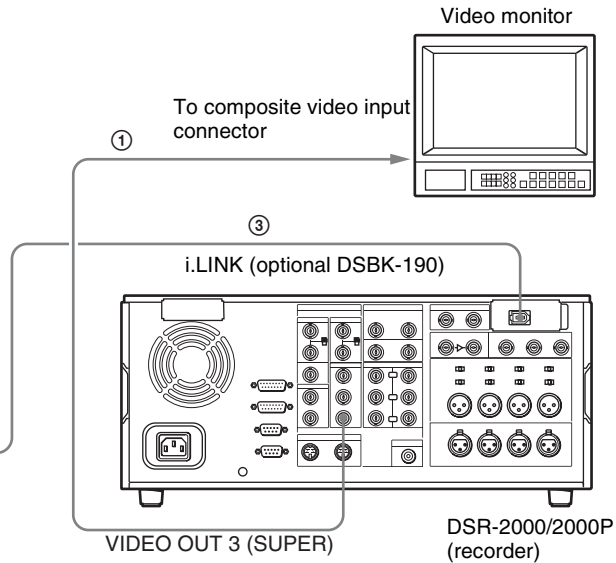

③: i.LINK cable (not supplied)

**DSR-2000/2000P (recorder) settings**

i.LINK button: Lit
 SDT/i.LINK button: i.LINK

For details about the settings of the DSR-2000/2000P, refer to the operating instructions for the unit.

3-1-6 Using the RM-280 Editing Controller

You can connect an RM-280 Editing Controller to this unit and use it as an editor or as a remote controller.

Using the RM-280 as an editor

You can perform assemble and insert editing by connecting this unit, a VTR, and an RM-280 Editing Controller.

When configuring an editing system that includes this unit and another VTR, use this unit as the player (feeder).

For information about connections, refer to the Operation Manual for the RM-280.

RM-280 settings

EDITOR/REMOTE CONTROL switch: EDITOR

Setup menu item 11 "P ST DLY": LEARN

For settings on the recorder VTR, refer to the Operation Manual for the RM-280.

PDW-R1 settings

Remote control switch (see page 12): REMOTE
 Extended menu item 214 "REMOTE INTERFACE":
 9PIN

Note

The RM-280 has not memorized the start delay of this unit. Before editing, have the RM-280 memorize the start delay of this unit. (Use the learn function of the RM-280.)

Using the RM-280 as a remote controller

You can connect this unit to the RM-280 with an optional 9-pin remote cable to perform editing operations such as thumbnail search, scene selection, and essence mark

recording from the RM-280 (when XDCAM mode is selected).

RM-280 settings

EDITOR/REMOTE CONTROL switch: REMOTE CONTROL

Setup menu item 19 “FNC MODE”: XDCAM

For information about function assignments to PF keys in XDCAM mode, refer to the Operation Manual for the RM-280.

PDW-R1 settings

Remote control switch (see page 12): REMOTE

Extended menu item 214 “REMOTE INTERFACE”:
9PIN

Line mode	7	6	5	4	3	2	1	0
525/60	OFF	–	–	OFF	–	–	–	–
625/50	OFF	–	–	OFF	–	–	–	–

- Right switch

Line mode	7	6	5	4	3	2	1	0
525/60	OFF	–	OFF	ON	OFF	OFF	ON	ON
625/50	ON	–	OFF	ON	OFF	OFF	ON	ON

PVE-500

No settings required.

3-1-7 Editing Control Unit Settings

When connecting an editing control unit to use with this unit, make the following settings, depending on the editing control unit model.

BVE-600/700/900/910/2000/9100

Set VTR constants as follows.

Line mode	VTR CONSTANT 1							
	1	2	3	4	5	6	7	8
525/60	A0	92	00	96	05	05	03	80
625/50	A1	92	00	7D	05	05	03	80

Line mode	VTR CONSTANT 2							
	1	2	3	4	5	6	7	8
525/60	0A	07	FE	00	80	5A	FF	5A
625/50	0A	07	FE	00	80	4C	FF	4B

FXE-100/120

Set VTR constants as follows.

Line mode	1	2	3	4	5	6	7	8
525/60	A0	92	00	96	05	05	03	80
625/50	A1	92	00	7D	05	05	03	80

Line mode	9	10	11	12	13	14	15
525/60	0A	07	FE	00	80	5A	FF
625/50	0A	07	FE	00	80	4C	FF

RM-450

Set the DIP switches as follows.

- Left switch

3-2 Power Preparations

This unit can be powered by a battery pack, DC power, or AC power.

3-2-1 Using AC Power

Connect an AC power source (100 V to 240 V AC, 50/60 Hz) to the ~ AC IN connector on the right side of the unit with an AC power cord (not supplied, *see page 133*).

3-2-2 Using DC Power

Connect a DC power source to the DC IN 12V connector on the right side of the unit.

3-2-3 Using a Battery Pack

Usable battery packs

The battery packs usable with this unit are as follows.
BP-GL95, BP-GL65, BP-L80S, BP-L60S

To attach a battery pack

Proceed as follows.

- 1 Remove the cover of the battery pack shoe.

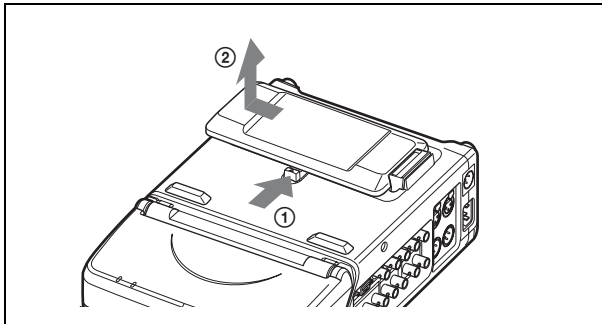

- 2 Fit the battery pack.

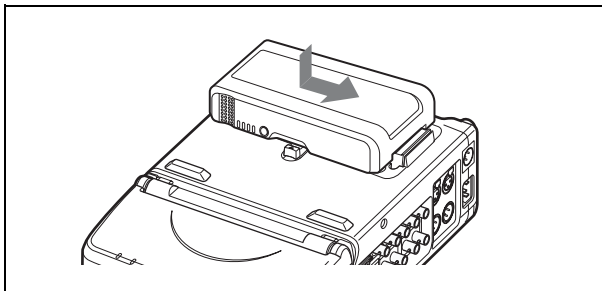

To remove the battery pack

Follow the above procedure in the reverse flow. After the battery pack is removed, replace the cover of the battery pack shoe.

When several power sources are connected

The following table shows the automatically selected power source that drives this unit.

Power types			Power that drives this unit
AC power	DC power	Battery pack	
Connected	Connected	Mounted	AC power ^{a)}
Connected	Connected	—	AC power ^{a)}
Connected	—	Mounted	AC power ^{b)}
—	Connected	Mounted	DC power ^{c)}

- a) Switches to DC power immediately if AC power supply is interrupted.
 b) Switches to battery pack power immediately if AC power supply is interrupted.
 c) Does not switch to battery pack power, even if DC power supply is interrupted. To drive this unit from the battery pack, disconnect the DC power connector from the DC IN 12V connector.

3-3 Setup

The principal setup operations before operating this unit can be carried out using setup menus. The setup menus of this unit comprise a basic setup menu and an extended setup menu. The contents of these menus are as follows.

Basic setup menu:

- Items relating to the hours meter
- Items relating to operation
- Items relating to menu banks

Extended setup menu:

- Items relating to control panels
- Items relating to the remote control interface
- Items relating to editing operations
- Items relating to preroll
- Items relating to disc protection
- Items relating to the time code, metadata, and UMID
- Items relating to video control
- Items relating to audio control
- Items relating to digital processing

For detailed information about the items, except for the basic menu items relating to the hours meter, of these menus and how to use them, see Chapter 7 “Menus” (page 89). For detailed information about menu operations relating to the hours meter, see 8-1-1 “Digital Hours Meter” (page 120).

This unit allows four different sets of menu settings to be saved in what are termed “menu banks” numbered 1 to 4. Saved sets of menu settings can be recalled for use as required.

For more information about the menu banks, see “Menu bank operations (menu items B01 to B13)” (page 96) and the description of maintenance menu item “SETUP MAINTENANCE” — “SETUP BANK4” (page 113).

3-4 Setting the Date and Time

When using this unit for the first time, you should set the date and time as follows.

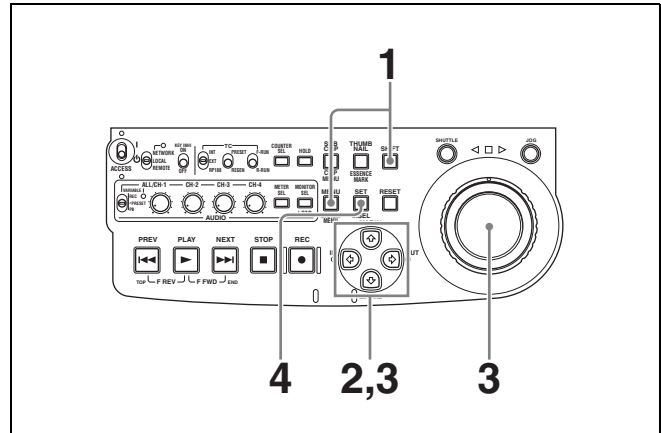

- 1 Holding down the SHIFT button, press the MENU button.
- 2 Select “DATE/TIME PRESET” using the \updownarrow button or \updownarrow button, then press the \rightarrow button.

The system menu appears on the video panel.

The date and time setting screen appears on the monitor, allowing you to set the following items.

- YEAR: Calendar year
- MONTH: Month
- DAY: Day
- TIME: Time
- TIME ZONE: Time zone (Difference from UTC)

- 3 Set the date, time and time zone.

You can change the setting of the flashing digits.

To change the flashing digits

Use the arrow buttons (\leftarrow , \rightarrow).

To increase or decrease the values of the flashing digits

Use the arrow buttons (\updownarrow , \updownarrow) or jog dial.

- 4 Press the SET button.

The date, time and time zone settings are stored.

To return to the previous menu page

Press the MENU button.

To exit the menu

Press the MENU button twice in succession.

Note

The time zone is reset to the factory default when you execute the maintenance menu item “RESET ALL SETUP.” You will need to set it again. The date and time are not reset.

3-5 Superimposed Text Information

The video signal output from the VIDEO OUT 2 (SUPER) connector or the SDI OUT (SUPER) connector contains superimposed text information, including time code, menu settings, and alarm messages.

Adjusting the text display

You can adjust the position, size and type of the superimposed text using basic menu items 002, 003, 005, 009, 011, and 012.

For details, see 7-2-1 “Items in the Basic Setup Menu” (page 90).

Information displayed

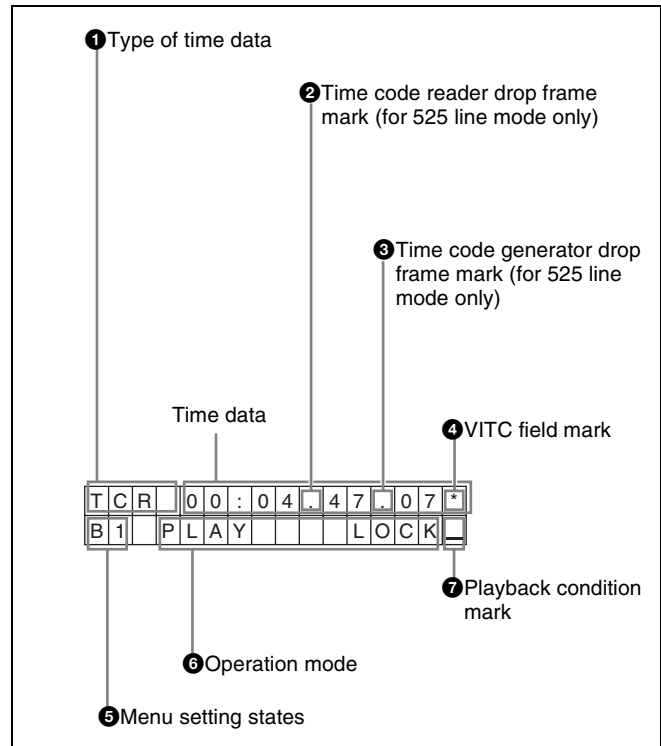
**Note**

The display shown above corresponds to the factory default settings of the unit. You can change the type of information to be displayed in the lower line of the display by changing the setting of basic menu item 005 “DISPLAY INFORMATION SELECT.”

For details, see 7-2-1 “Items in the Basic Setup Menu” (page 90).

1 Type of time data

Display	Meaning
CNT	Counter data
TCR	TC reader time code data
UBR	TC reader user bits data
TCR.	VITC reader time code
UBR.	VITC reader user bits data
TCG	TC generator time code
UBG	TC generator user bits data
IN	IN point time data
OUT	OUT point time data
DUR	Duration between IN point and OUT point

Note

If the time data or user's bits cannot be read correctly, they will be displayed with an asterisk. For example, "T*R", "U*R", "T*R." or "U*R."

2 Time code reader drop frame mark (for 525 line mode only)

“.”: Indicates drop frame mode
 “:”: Indicates non-drop-frame mode

3 Time code generator drop frame mark (for 525 line mode only)

“.”: Indicates drop frame mode (factory default setting)
 “:”: Indicates non-drop-frame mode

4 VITC field mark

“ ” (blank): Fields 1 and 3 (for 525/60 mode) or fields 1, 3, 5 and 7 (for 625/50 mode)
 “ * ”: Fields 2 and 4 (for 525/60 mode) or fields 2, 4, 6 and 8 (for 625/50 mode)

5 Menu setting states

Display	Description
B1	The current menu settings are the same as the settings in menu bank 1.
B2	The current menu settings are the same as the settings in menu bank 2.
B3	The current menu settings are the same as the settings in menu bank 3.
B4	The current menu settings are the same as the settings in menu bank 4.
DF	The current menu settings are the same as the factory defaults.
No display	The current menu settings are different from all of the above.

6 Operation mode

The field is divided into two blocks as shown below.

- Block A displays the operation mode.

- Block B displays the servo lock status or playback speed.

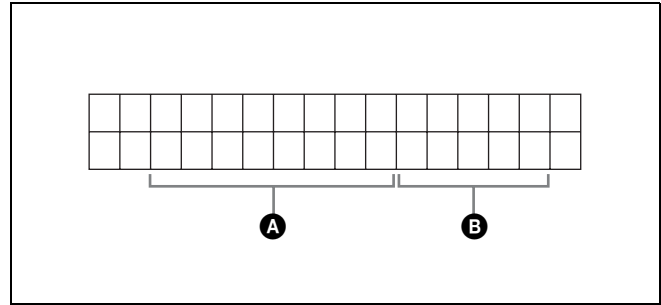

Display		Operation mode
Block A	Block B	
DISC OUT		Disc is not loaded.
LOADING		Disc is being loaded.
UNLOADING		Disc is being unloaded.
STANDBY OFF		Standby off mode
STOP		Stop mode
NEXT		Cuing up to the first frame of the next clip.
PREV		Cuing up to the first frame of the current clip.
F.FWD		Fast forward search
F.REV		Fast reverse search
PLAY		Playback mode (servo unlocked)
PLAY	LOCK	Playback mode (servo locked)
REC		Record mode (servo unlocked)
REC	LOCK	Record mode (servo locked)
JOG	STILL	A still picture in jog mode
JOG	FWD	Jog mode in forward direction
JOG	REV	Jog mode in reverse direction
SHUTTLE	STILL	A still picture in shuttle mode
SHUTTLE	(Speed)	Shuttle mode
TOP 001/xxx		Cuing up to the first frame of the first clip.
END xxx/xxx		Cuing up to the last frame of the last clip.
PREROLL		Cuing up during thumbnail search

7 Playback condition mark

One of three channel condition marks is displayed when the ACCESS indicator is lit during any mode except recording. The three channel condition marks indicate the following three stages.

Display	Name	Description
—	Green condition	There is no problem with the playback condition. This unit and the disc can be used just as they are. This corresponds to the “green” channel condition indicator of a VTR.
=	Yellow condition	The playback condition has deteriorated to some degree. There are no read errors, but you should take the action described in the next section. This corresponds to the “yellow” channel condition indicator of a VTR.
≡	Red condition	The playback condition has deteriorated. There are no read errors, ^{a)} but you should take the action described in the next section. This corresponds to the “red” channel condition indicator of a VTR.

a) Read errors will occur if the playback condition continues to deteriorate. If a read error occurs, a “Disc Error!” alarm appears in the time data display, the picture freezes, and audio is muted.

To display playback condition marks, set basic menu item 012 “CONDITION DISPLAY ON VIDEO MONITOR” to “ena,” and set basic menu item 005 “DISPLAY INFORMATION SELECT” to “T&sta.”

For details about operation, see 7-2-2 “Basic Menu Operations” (page 94).

Playback condition displays

You can be alerted in advance to deteriorating playback conditions and to error correction rates which are approaching their limits.

Deteriorating playback may be due to the following causes.

- Scratches and dust on the disc surface
This includes fingerprints, dust from the air, tar from cigarette smoke, and so on.
Scratches and soiling which occur before recording are not a problem because they are registered in advance as defects, and recording avoids them. However, scratches and soiling which occur after recording can lead to deteriorating playback conditions.
- Aging of disc recording layers
Over several decades, the recording layers of optical discs can age and cause deteriorating playback conditions.
You can use this function to check archival discs and other discs which have been stored for extended periods, so that you can take action before the deterioration progresses further.

- Deteriorating laser diodes performance
The performance of the laser diodes used in optical heads can worsen with age, leading to deteriorating playback conditions.
You can use the digital clock to check the total optical output time of optical heads.

For details, see 8-1-1 “Digital Hours Meter” (page 120) about this setting.

Refer to the Maintenance Manual for an approximate guide to when it is time to replace optical heads.

To prevent playback conditions from deteriorating

Pay attention to the following points when handling discs.

- Do not open disc cartridges and touch discs directly with your hands.
- Do not store for long periods in locations which are dusty or exposed to air circulated by fans.
- Do not store for long periods under high temperatures or in locations exposed to direct sunlight.

If playback conditions have deteriorated

If a yellow or red playback condition mark appears, check the following points.

Whether the disc displays the same playback condition

on other XDCAM devices: If so, the surface of the disc may be dirty or scratched, or the performance of the recording layers on the disc may have worsened due to age. Do not use discs with these symptoms.

Whether every disc inserted into an XDCAM device

displays the same playback conditions: If so, the performance of the laser diodes may have deteriorated. Check the total optical output time.

3-6 Handling Discs

3-6-1 Discs Used for Recording and Playback

This disc recorder uses the following disc for recording and playback: PFD23 Professional Disc ¹⁾ (capacity 23.3 GB)

1) Professional Disc is a trademark of Sony Corporation.

Note

It is not possible to use the following discs for recording or playback:

- Blu-ray Disc
- Professional Disc for Data

3-6-2 Notes on Handling

Handling

The Professional Disc is housed in a cartridge, and is designed to allow handling free of risk from dust or fingerprints. However, if the cartridge is subjected to a severe shock, for example by dropping it, this can result in damage or scratching of the disc. If the disc is scratched, it may be impossible to record video/audio, or to play back the content recorded on the disc. The discs should be handled and stored carefully.

- Do not touch the surface of the disc itself within the cartridge.
- Deliberately opening the shutter may cause damage.
- Do not disassemble the cartridge.
- The supplied adhesive labels are recommended for indexing discs. Apply the label in the correct position.

Storage

- Do not store discs where they may be subjected to direct sunlight, or in other places where the temperature or humidity is high.
- Do not leave cartridges where dust may be able to gain ingress.
- Store cartridges in their cases.

Care of the discs

- Remove dust and dirt on the outside of a cartridge using a soft dry cloth.
- If condensation forms, allow ample time to dry before use.

3-6-3 Write-Protecting Discs

To protect the content recorded on the disc from accidental erasure, move the Write Inhibit tab on the lower surface of

the disc in the direction of the arrow, as shown in the following figure.

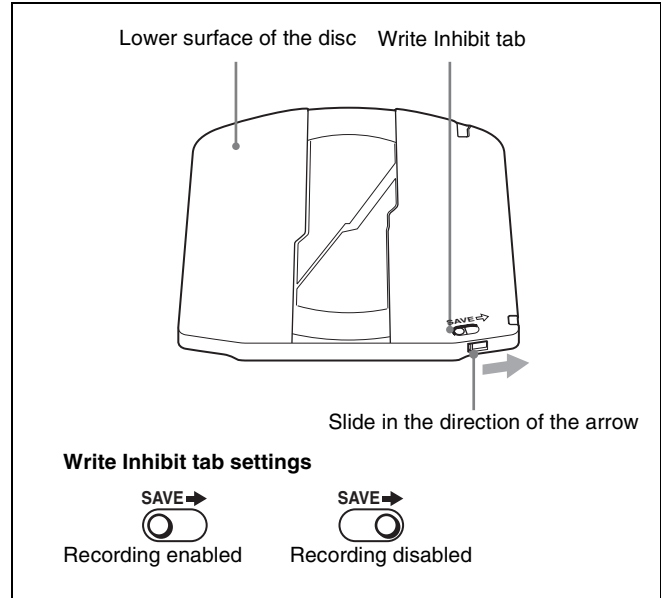

You can lock individual clips to prevent them from being deleted. For details, see “Locking clips” (page 55).

3-6-4 Loading and Unloading a Disc

When the on/standby switch indicator is lit green, you can load and unload a disc as shown in the following figure.

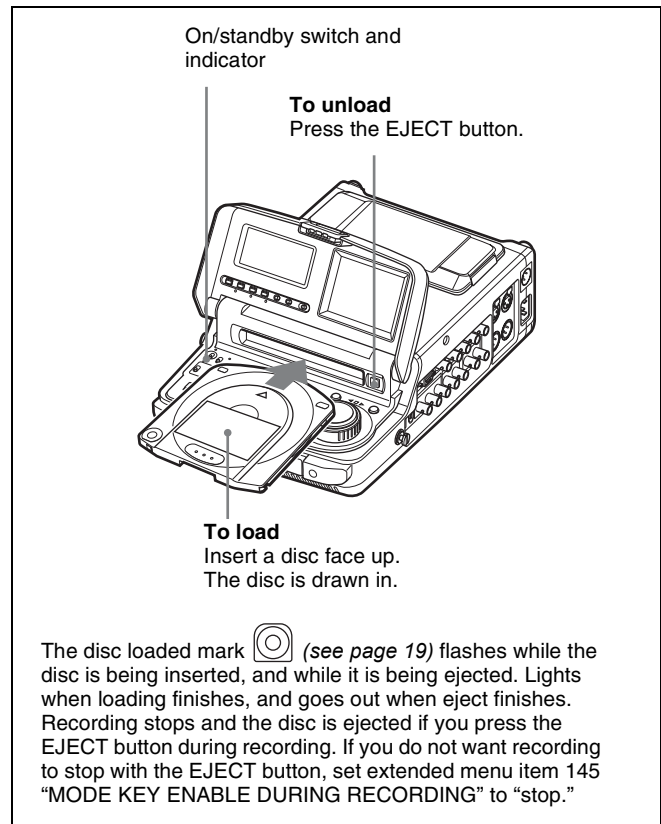

If message “HUMID!” appears in the time data display

There is moisture condensation in the unit.

For the steps to take when the message appears, see 8-2 “Condensation” (page 121).

3-6-5 Formatting a Disc

An unused disc requires no formatting operation. The disc is automatically formatted when loaded into this unit. To format a recorded disc, load the disc into the unit, then proceed as follows.

Note

When a recorded disc is formatted, all the data on the disc is erased. (Locked clips (see page 55) are also erased.)

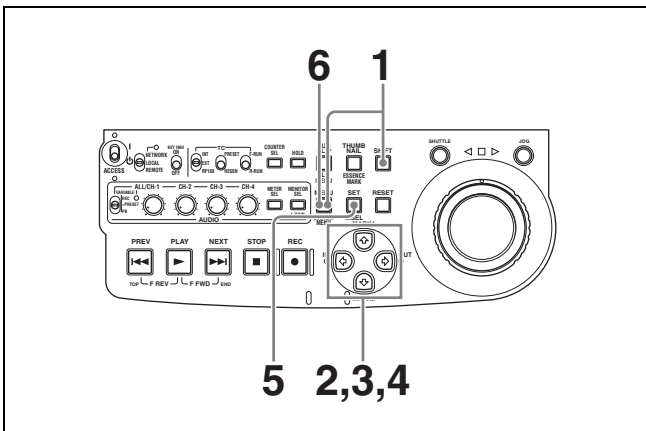

- 1** Holding down the SHIFT button, press the MENU button.
The system menu appears on the monitor screen.
- 2** Select “DISC MENU” using the \updownarrow button or \leftarrow button, then press the \rightarrow button.
The menu item “FORMAT” is displayed.
- 3** Select “FORMAT” using the \updownarrow button or \leftarrow button, then press the \rightarrow button.
The menu item “QUICK FORMAT” is selected.
- 4** Press the \rightarrow button.
The message “QUICK FORMAT OK?” appears.

To return to the previous menu page without formatting the disc

Press the RESET button.

- 5** Press the SET button.
Formatting is completed and the message “FORMAT COMPLETED.” appears.

- 6** Press the MENU button.

This exits the menu.

To format several discs in succession

- 1** Carry out steps **1** to **5** in the previous procedure, and then press the EJECT button to eject the disc.
- 2** Insert the next disc that you want to format.
The message “QUICK FORMAT OK?” appears.
- 3** Press the SET button.
- 4** When the message “FORMAT COMPLETED.” appears, press the EJECT button to eject the disc.
- 5** Repeat steps **2** to **4** for all of the discs that you want to format.

3-6-6 To Eject Discs With the Unit Powered Off

When battery power is low and at other times, it may not be possible to eject discs by pressing the EJECT button. In these situations, you can use the following as an emergency procedure to eject a disc manually.

- 1** Power the unit off.
- 2** Open the rubber cover and, using a Phillips screwdriver, rotate the red screw in the counterclockwise direction.

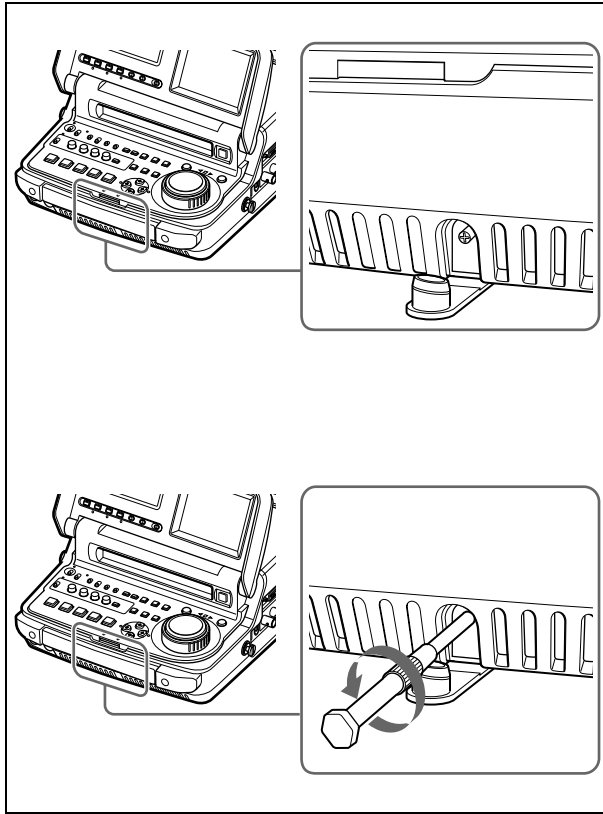

The disc is ejected.

After removing the disc, you do not need to return the screw to its original position. Normal operation will resume when the unit is powered on again.

3 Close the rubber cover firmly.

3-6-7 Handling of Discs When Recording Does Not End Normally (Salvage Function)

Recording processing does not end normally when the primary power ¹⁾ of this unit is lost during recording. Because the file system is not updated, video and audio data recorded in real time is not recognized as files and clip contents recorded up to that point are lost. However, this unit has a salvage function which can hold losses to the minimum by reconstructing clips on such discs.

Note that no recorded clip contents are lost when the on/standby switch on the control panel is set to standby, because the unit does not enter standby mode until after the end of recording processing.

1) Primary power is lost when the AC power switch on the rear panel is turned off, the AC power cord is disconnected, DC power is turned off, the battery pack is exhausted, the battery pack is removed, and so on.

Notes

- Do not turn this unit's primary power off until recording processing has finished and the ACCESS indicator has gone out.
- This function salvages as much recorded material as possible after an unforeseen accident, but 100% restoration cannot be guaranteed.
- Even when this function is used, it is not possible to recover data from immediately before the interruption of recording. The amount of data lost is as follows.
 - Quick salvage: From 2 to 4 seconds of data before the interruption of recording.
 - Full salvage: From 4 to 6 seconds of data before the interruption of recording.

Quick salvage

When the unit is powered on again after a recording interruption due to power off, with the disc still loaded in the unit, clips are reconstructed on the basis of backup data stored in nonvolatile memory and markers recorded on the disc.

Processing time is about 5 seconds.

Full salvage

When a disc that was manually ejected from a device subjected to a recording interruption due to power off is loaded into this unit, clips are reconstructed on the basis of markers recorded on the disc. Nonvolatile memory cannot be used, so processing takes longer than for a quick salvage (about 30 seconds, although it depends on the state of the disc).

Proceed as follows to perform a full salvage.

- 1 Insert the disc on which recording did not end normally.

The message "Salvage ?" appears.

- 2 Do one of the following.

To salvage

Press the SET button.

Processing begins and the message "Executing." appears.

Notes

- If the REC INHI indicator (*see page 18*) is lit, the message "EJECT?" appears. Eject the disc, set the Write Inhibit tab to the recording enable position, and insert the disc again.
- This operation cannot be cancelled once it begins.

The message "Complete" appears when processing finishes. If the message reads "Incomplete!," the clips that failed were lost.

To exit without salvaging

Press the RESET button.

The state of section where recording was interrupted is saved, but no salvage processing is done.

Sections which were recorded normally can be played back, but no new recording can be done on the disc. (A quick format can be done on the disc, although all of its contents will be lost.)

Note

Unless clips are salvaged, the message “Salvage ?” appears again the next time the disc is inserted or the unit is powered on.



4-1 Recording

This section describes video and audio recording on the unit.

4-1-1 Preparations for Recording

Button/switch settings

Before beginning recording, make any necessary button/switch settings.

For details of the settings of the buttons/switches, see the pages indicated in parenthesis.

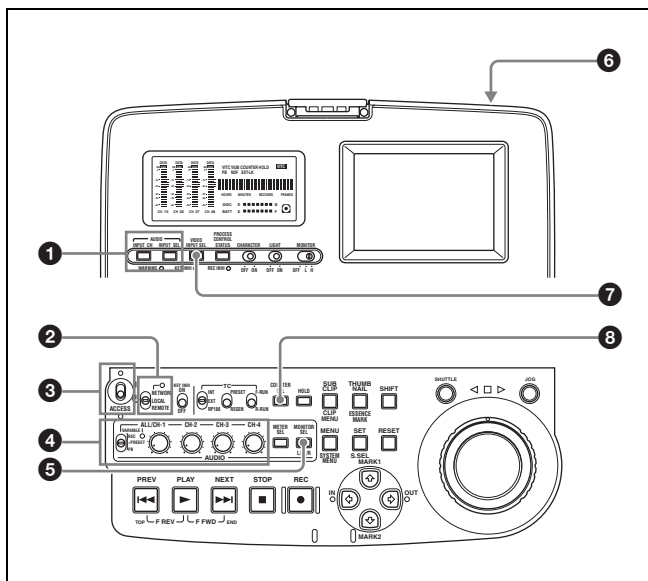

1 AUDIO INPUT CH button (page 19) and AUDIO INPUT SEL button (page 19)

Select the input audio signal.

2 Remote control switch (page 12)

Set to LOCAL.

3 On/standby switch (page 12)

Indicator (I) lit green.

4 VARIABLE switch (page 15) and ALL/CH-1, CH-2 to CH-4 adjustment knobs (page 15)

Adjust the audio recording levels (page 43).

5 AUDIO MONITOR SEL button (page 15)

Select the audio channels to monitor.

6 AC power switch (rear panel) (page 11)

Set to the I (on) position.

If you are using DC power or a battery pack, connect the DC power or mount the battery pack on the battery pack shoe before recording.

7 VIDEO INPUT SEL button (page 19)

Select the input video signal.

8 COUNTER SEL button (page 13)

Select the data (elapsed recording time, time code value or user bit data) to show in the time data display. When displaying the time code value, select TC or VITC with extended menu item 629 "TC SELECT."

Setting the recording format

Before recording, it is necessary to set the recording format for each of video and audio.

Note

It is not possible to combine different recording formats on a single disc. When the format of previously recorded sections on the disc does not match the current recording format of this unit, the disc is record inhibited and the REC INHI lights.

To set the video recording format

Use basic menu item 031 “RECORDING FORMAT” to select the video recording format from MPEG IMX 50 Mbps, MPEG IMX 40 Mbps, MPEG IMX 30 Mbps, and DVCAM.

The factory default setting is IMX50.

For details of the basic menu operations, see 7-2-2 “Basic Menu Operations” on page 94.

To set the audio recording format

When using the MPEG IMX 50Mbps/40Mbps/30Mbps for video: Use the maintenance menu item “AUDIO CONFIG” to select 16 bits/8 channels or 24 bits/4 channels.

The factory default setting is 16 bits/8 channels.

When using the DVCAM format for video: Selection is not necessary. The format of 16 bits/4 channels is selected automatically.

For details of the maintenance menu operations, see 7-4-2 “Maintenance Menu Operations” on page 114.

File writing formats with FAM and FTP connections

It is not necessary to set the video recording format (IMX50/IMX40/IMX30/DVCAM) and the audio recording format (16bit × 8ch/24bit × 4ch) before writing files.

The file formats which can be written to the disc depend on whether clips are already recorded on the disc.

When you insert a disc with no recorded clips: Files in all of the above formats can be written.

When you insert a disc with recorded clips: Files in the same video and audio formats as the clips on the disc can be written.

Making thumbnail image settings

As required, you can select which frame to display as a clip’s thumbnail image. (When the unit is shipped from the factory, it is set up to display the first frame as the thumbnail.)

For example, if all clips have the same image in their first frames, you can specify a frame a few seconds after the start of the clip, so that thumbnails will not all show the same image.

To specify the frame to use as the thumbnail image

Set extended menu item 143 “INDEX PICTURE POSITION” to a number in the range from 0 to 10, in units of 1 second.

See 7-3-2 “Extended Menu Operations” (page 108) for more information about how to make extended menu settings.

To adjust the audio recording levels

When carrying out audio recording at a reference level

Set the VARIABLE switch (*see page 15*) to PRESET. The audio signals will be recorded at a preset reference level. Use the maintenance menu item “AUDIO CONFIG” to set the audio input level and reference level.

For details of the maintenance menu operations, see 7-4-2 “Maintenance Menu Operations” on page 114.

Manually adjusting the audio recording levels

Set the VARIABLE switch (*see page 15*) to REC and adjust the ALL/CH-1 and CH-2 to CH-4 adjustment knobs so that the audio level indications on the audio level meters (*see page 18*) do not exceed 0 dB for a maximum volume. Carry out the adjustment in E-E mode.

To select the E-E mode, see extended menu item 108 “AUTO EE SELECT.”

To adjust the audio recording levels for channels 1 to 8 simultaneously, set extended menu item 131 “AUDIO VOLUME” to “all” and turn the ALL/CH-1 adjustment knob.

4-1-2 Recording Time Code and User Bit Values

There are the following four ways of recording time code:

- Internal Preset mode, which records the output of the internal time code generator, set beforehand to an initial value. The following run modes can be selected.
 - Free Run: Time code advances continually.
 - Rec Run: Time code advances only during recording.
- Internal Regen mode, which records the output of the internal time code generator, initialized to time code following continuously upon the time code of the last frame of the last clip on the disc.
- External Regen mode, which records the output of the internal time code generator, synchronized to an external time code generator. As the external input, the time code input to any of the following connectors can be selected.
 - TIME CODE IN connector: LTC
 - VIDEO IN connector: VITC

- S400 (i.LINK) connector: TC or VITC
- SDI IN connector: SMPTE RP188 LTC
- External Preset mode, which directly records the input of an external time code generator. As the external input, the time code input to any of the following connectors can be selected.
 - TIME CODE IN connector: TC
 - S400 (i.LINK) connector: TC
 - SDI IN connector: SMPTE RP188 LTC

As shown in the following table, you can switch between different time code recording modes by combining switch settings in the time data settings section with the selection of a video input signal and settings of extended menu item 629.

Time code recording mode	Time data settings section switch			VIDEO INPUT SEL button	Item 629	Reference	
	INT/EXT/ RP188	PRESET/ REGEN	F-RUN/ R-RUN				
Internal Preset Free Run	INT	PRESET	F-RUN	–	–	"To record time code after setting an initial value" (page 44)	
Internal Preset Rec Run			R-RUN	–	–		
Internal Regen	INT	REGEN	–	–	–	"To record time code that follows sequentially upon the last recorded time code" (page 46)	
External Regen (TC IN connector: LTC)	EXT	REGEN	–	SDI/ COMPOSITE/ SG	tc	"To record with the internal time code generator synchronized to external time code" (page 46)	
External Regen (VIDEO IN connector: VITC)					vitc		
External Regen (i.LINK connector: TC)					i.LINK		tc
External Regen (i.LINK connector: VITC)					vitc		
External Regen (SDI IN connector: SMPTE RP188 LTC)	RP188	REGEN	–	SDI	–		
External Preset (TC IN connector: TC)	EXT	PRESET	–	SDI/ COMPOSITE/ SG	–	"To record external time code directly" (page 47)	
External Preset (i.LINK connector: TC)					i.LINK		–
External Preset (SDI IN connector: SMPTE RP188 LTC)					RP188		PRESET

To record time code after setting an initial value

Set the following switches beforehand.

- INT/EXT/RP188 switch: INT
- PRESET/REGEN switch: PRESET
- F-RUN/R-RUN switch: F-RUN or R-RUN

See 7-3-2 "Extended Menu Operations" (page 108) for more information about how to make extended menu settings.

Then set an initial value as described below, and carry out recording (see page 48).

To set an initial value

Proceed as follows.

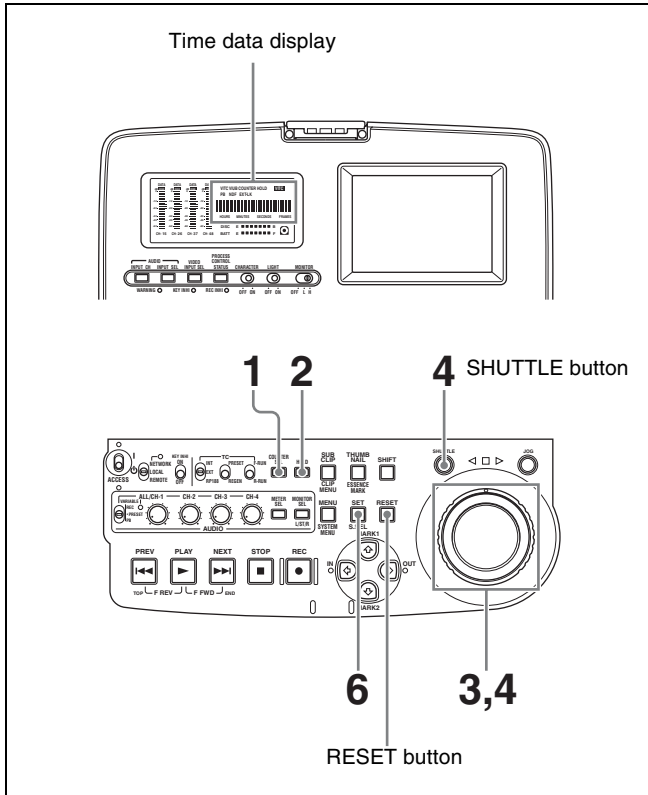

- 1 Watching the indicators above the time data display, press the COUNTER SEL button to select TC.
- 2 Press the HOLD button.
The SHUTTLE button lights and the first two digits of the time code shown in the time data display start flashing.

To set all digits to 0

Press the RESET button.

- 3 Select the digits to set by rotating the shuttle dial or jog dial.
The flashing digits change to the next two digits on the right when you rotate the shuttle dial or jog dial clockwise, and to the next two digits on the left when you rotate it counterclockwise.
- 4 Set the value for the flashing digits by rotating the shuttle dial or jog dial while holding the SHUTTLE button.
- 5 Repeat steps 3 and 4 until you finish setting all digits.
- 6 Press the SET button.
 - An initial time code value is set and the monitor returns to the time code display before the HOLD button was pressed in step 2.

- If the F-RUN/R-RUN switch is set to F-RUN, the time code starts advancing from the initial value immediately.

To set time code to the time of the internal clock

You can record time code synchronized to the time of the internal clock.

To do so, set the INT/EXT/RP188 switch to INT, set the PRESET/REGEN switch to PRESET, and then proceed as follows.

- 1 Carry out steps 1 and 2 of the previous section, “To record time code after setting an initial value.”
- 2 With the SHUTTLE button held down, rotate the jog dial in the counterclockwise direction. Stop rotating when “CLOCK” appears in the time data display and the video panel.
- 3 Press the SET button.

To set user bits

You can record up to eight hexadecimal digits of information (date, time, clip name, etc.) in the time code track.

Proceed as follows.

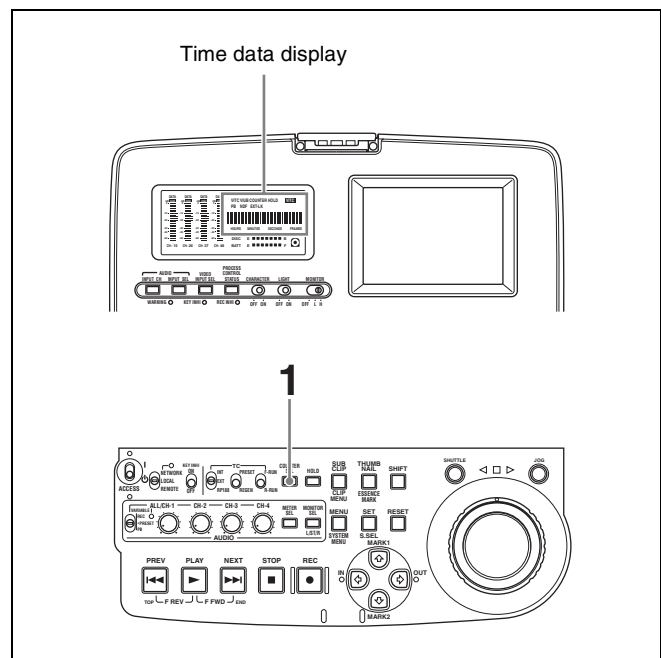

- 1 Watching the indicators above the time data display, press the COUNTER SEL button to select UB.
- 2 Carry out steps 2 to 6 of the section “To set an initial value” (page 44).

Settings are made in hexadecimal (0, 1, 2,... 8, 9, A, B,... E, F).

To record time code that follows sequentially upon the last recorded time code

You can record time code so that it is continuous from one clip to the next on the disc.

Set the INT/EXT/RP188 switch to INT and the PRESET/REGEN switch to REGEN beforehand. When this setting is in force, the unit reads the time code of the last frame of the last recorded clip on the disc before starting to record, and internally generates time code that follows upon the recorded time code.

In this case, the setting of extended menu item 628 “DF MODE” is ignored. New time code is recorded in the drop-frame mode of the last recorded time code on the disc.

To record with the internal time code generator synchronized to external time code

You can record with the internal time code generator synchronized to time code input from an external device. Use this method to synchronize the time code generators of a number of recorders, or to carry out recording maintaining the synchronization between the source video and time code.

In this case, the settings of the F-RUN/R-RUN switch and extended menu item 628 “DF MODE” are ignored.

You can synchronize the internal time code generator to one of the following external time codes.

- TC input to this unit’s TC IN connector
- VITC in a video signal input to this unit
- SMPTE RP188 LTC in an SDI signal input to this unit
- i.LINK TC input to this unit’s **i**S400 (i.LINK) connector
- i.LINK VITC input to this unit’s **i**S400 (i.LINK) connector

Use the following procedure to synchronize the internal time code generator according to the type of external time code.

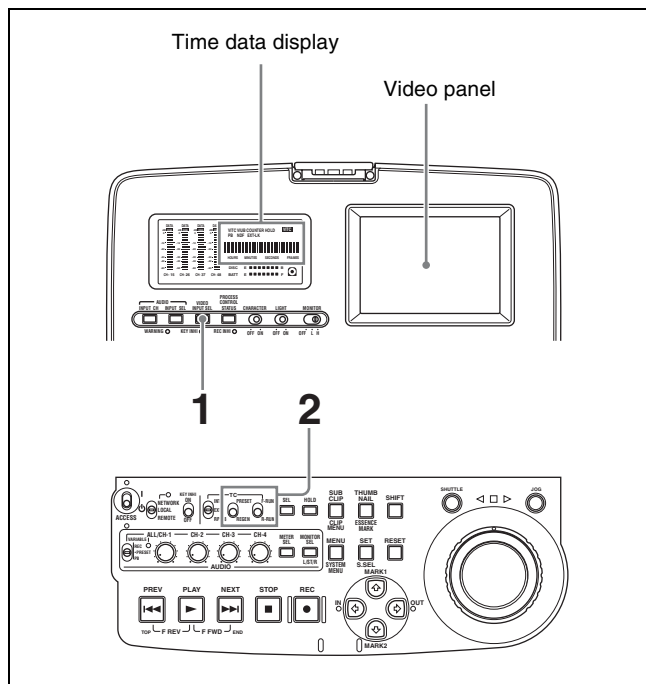

- 1 Make either of the following connections and settings.

To synchronize to time code input to the TC IN connector

Connect the time code output from the external device to the TC IN connector. Press the VIDEO INPUT SEL button and, while viewing the time data display or the video panel, select one of SDI, COMPOSITE, or SG.

To synchronize to VITC in an input video signal

Connect a video signal containing VITC to the VIDEO IN connector or the SDI IN connector. Press the VIDEO INPUT SEL button and, while viewing the time data display or the video panel, select COMPOSITE or SDI.

To synchronize to SMPTE RP188 LTC in an SDI signal

Connect an SDI signal containing SMPTE RP188 LTC to the SDI IN connector.

To synchronize to i.LINK TC

Connect an i.LINK signal to the **i**S400 (i.LINK) connector. Press the VIDEO INPUT SEL button and, while viewing the time data display or the video panel, select i.LINK.

To synchronize to i.LINK VITC

Connect an i.LINK signal to the **i**S400 (i.LINK) connector. Press the VIDEO INPUT SEL button and, while viewing the time data display or the video panel, select i.LINK.

- 2 Make the following settings.

To synchronize to time code input to the TC IN connector

- Set the INT/EXT/RP188 switch to EXT and the PRESET/REGEN switch to REGEN.
- Set extended menu item 629 “TC SELECT” to “tc.”

To synchronize to VITC in an input video signal

- Set the INT/EXT/RP188 switch to EXT and the PRESET/REGEN switch to REGEN.
- Set extended menu item 629 “TC SELECT” to “vitc.”

To synchronize to SMPTE RP188 LTC in an SDI signal

Set the INT/EXT/RP188 switch to RP188 and the PRESET/REGEN switch to REGEN.

To synchronize to i.LINK TC

- Set the INT/EXT/RP188 switch to EXT and the PRESET/REGEN switch to REGEN.
- Set extended menu item 629 “TC SELECT” to “tc.”

To synchronize to i.LINK VITC

- Set the INT/EXT/RP188 switch to EXT and the PRESET/REGEN switch to REGEN.
- Set extended menu item 629 “TC SELECT” to “vitc.”

For details of menu setting operations, see Chapter 7 “Menus” on page 89.

This starts the internal time code generator running in synchronization with the external time code generator. Once the internal time code generator is synchronized with the external time code generator, even if the external time code generator connection is removed, the internal time code generator continues to run.

Notes

- When the input video signal selected is i.LINK or SDI, setting the INT/EXT/RP188 switch to EXT and the PRESET/REGEN switch to REGEN automatically synchronizes the internal time code generator to the time code received through the iS400 (i.LINK) connector or SDI IN connector.
- When the INT/EXT/RP188 switch is set to EXT and the PRESET/REGEN switch is set to REGEN, the internal time code advance mode and frame count mode (for 525 line mode only) are automatically set as follows.
Advance mode: free running
Frame count mode (for 525 line mode only): the same as the external time code signal (drop frame or non-drop frame)

To check the synchronization to the external signal

Press the STOP button to stop this unit, then press the REC button.

Check that the time code value shown in the time data display coincides with the external time code value.

To record external time code directly

You can record both of the following types of external time code directly.

- TC input to the TC IN connector of this unit
- i.LINK TC input to the iS400 (i.LINK) connector of this unit
- SMPTE RP-188 LTC in an SDI signal input to the SDI IN connector of this unit

When you use this method, the internal time code generator advances without being affected by the external time code.

To record the playback time code of external VTRs, the methods described above in “To record with the internal time code generator synchronized to external time code” are recommended.

Use the following procedure to record external time code directly, according to the type of external time code.

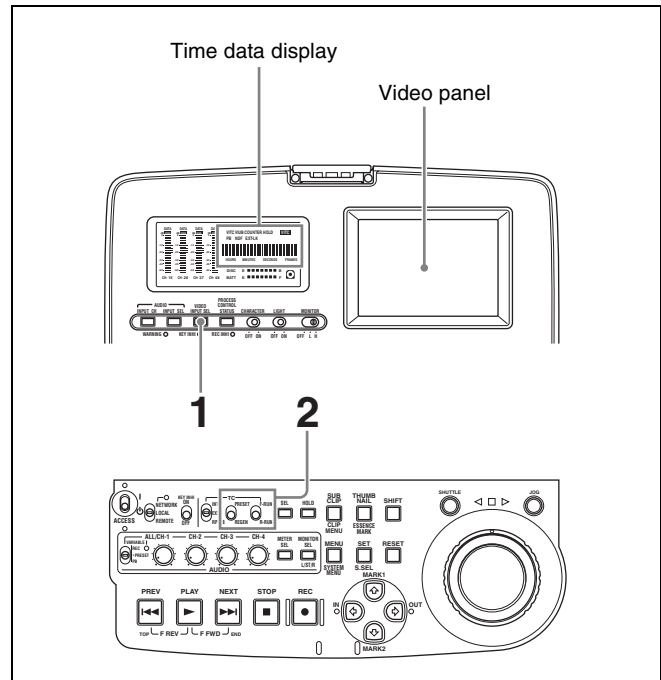

- 1 Make either of the following connections and settings.

To directly record TC input to the TC IN connector

Connect the time code output from the external device to the TC IN connector. Press the VIDEO INPUT SEL button and, while viewing the time data display or the video panel, select one of SDI, COMPOSITE, or SG.

To directly record i.LINK TC

Connect an i.LINK signal to the iS400 (i.LINK) connector. Press the VIDEO INPUT SEL button and, while viewing the time data display or the video panel, select i.LINK.

To directly record SMPTE RP-188 LTC in an SDI signal

Connect an SDI signal containing SMPTE RP188 LTC to the SDI IN connector. Press the VIDEO INPUT SEL button and, while viewing the time data display or the video panel, select SDI.

- 2 Set the PRESET/REGEN switch to PRESET, and set the INT/EXT/RP188 to one of the following.

To record TC input to the TC IN connector, or
i.LINK TC: EXT

To record SMPTE RP188 LTC: RP188

For details of menu setting operations, see Chapter 7 “Menus” (page 89).

4-1-3 Recording Operation

To record, proceed as follows.

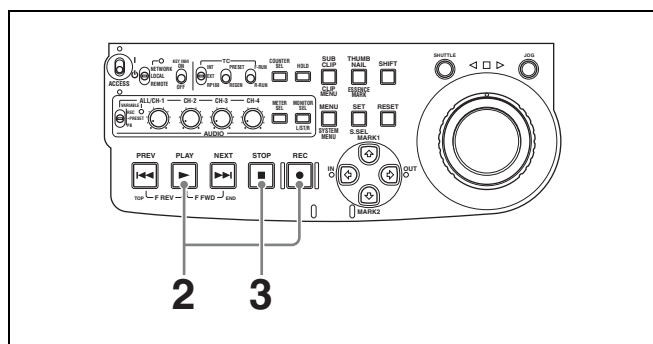

- 1 Insert a disc.

For details, see 3-6-4 “Loading and Unloading a Disc” on page 38.

- 2 Hold down the REC button, and press the PLAY button.

Recording starts.

- 3 To stop recording, press the STOP button.

If the disc becomes full

Recording stops and the message “ALARM DISC END.” appears on the video panel.

Notes

- The shortest clip that can be recorded is 2 seconds long. Even if recording start and stop operations are performed within 2 seconds, a 2-second clip is recorded.
- The maximum number of clips that can be recorded is 300. If the loaded disc already contains 300 clips, recording with the REC button is not possible. (The message “Disc Full!” appears in the time data display.)

- Do not allow the unit’s primary power to be lost during recording.¹⁾ This could cause the clip being recorded to be lost. (See 3-6-7 “Handling of Discs When Recording Does Not End Normally (Salvage Function)” on page 40.)

1) Primary power is lost when the AC power switch on the rear panel is turned off, the AC power cord is disconnected, DC power is turned off, the battery pack is exhausted, the battery pack is removed, and so on.

To record essence marks

A shot mark 1 essence mark or shot mark 2 essence mark is recorded if you hold down the ⚡/MARK1 or ⚡/MARK2 button and press the SET button during recording.

4-1-4 Auto Clip List Recording for Automatic Inclusion of Recorded Clips in Clip Lists

Auto clip list recording is a function for automatically including the clips generated by recording operations in a selected clip list. The updated clip list is saved to the disc. Proceed as follows.

- 1 Insert a disc.
- 2 Load a clip list from the disc.
 - To create a new clip list, load a NEW FILE (empty) clip list.
 - To add clips to an existing clip list, load that clip list.

For operations, see 5-3-1 “Loading a Clip List From Disc Into Unit Memory” (page 68).

- 3 Press the SUBCLIP button, turning it on.

The unit enters auto clip list recording mode, and the number of the clip list which is loaded in the current clip list appears.

- 4 Press the REC button to start recording.

A clip is generated automatically from the video and audio recorded in the interval from start to stop of recording, and added as a sub clip to the current clip list. When recording stops, the updated clip list is written to disc.

- 5 Repeat the process of recording and stopping until you have included all the required clips. To change the registered clip list, repeat step 2 to load the desired clip list.

To exit auto clip list recording mode

Press the SUBCLIP button, turning it off.

4-2 Playback

This section describes playback of video and audio.

Disc playback start position

Although this unit uses optical discs, it is designed to offer the most convenient features of tape playback by VTRs. One of these is the playback start position, which works in the same way as tape, as described below.

After playback stop

The unit stops at the position where the STOP button was pressed.

Press the PLAY button to resume playback at the stop position.

After recording

The unit stops at the position where recording ended.

To play back a clip, press the PREV button to move to the start frame of any clip, or press the PREV button with the PLAY button held down to move to any position.

After disc insertion

The unit stops at the position of the disc when it was most recently ejected.

Press the PLAY button to resume playback at the most recent position.

The playback position is saved to the disc when the disc is ejected, which allows playback to start at that position whenever it is loaded into any XDCAM player.

Note

This function is not available when the Write Inhibit tab of the disc is set to the recording disabled position, and when extended menu item 310 “REC INHIBIT” is set to “on.” The REC INHI indicator may light when neither of the above are true if the format of recorded sections on the disc is not the same as the recording settings of this unit. In this case, the playback position can be saved to the disc.

4-2-1 Preparations for Playback

Button/switch settings

Before beginning playback, make any necessary button/switch settings.

For details of the settings of the buttons/switches, see the pages indicated in parenthesis.

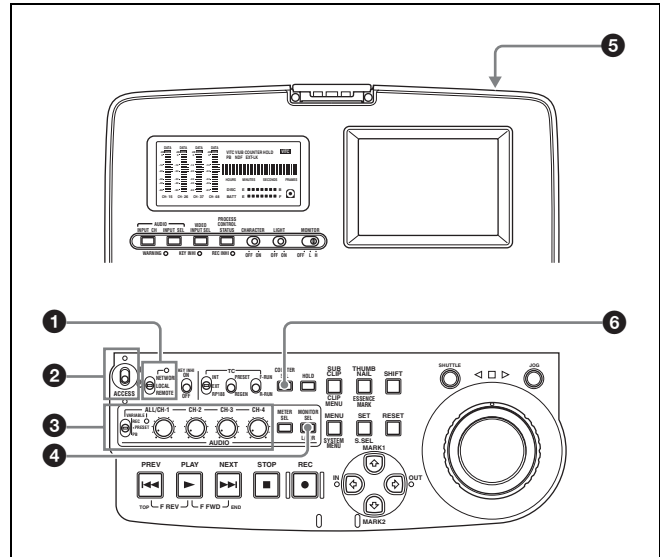

1 Remote control switch (page 12)

Set to LOCAL.

2 On/standby switch (page 12)

Indicator (I) lit green.

3 VARIABLE switch (page 15) and ALL/CH-1, CH-2 to CH-4 adjustment knobs (page 15)

Adjust the audio playback levels.

4 AUDIO MONITOR SEL button (page 15)

Select the audio channels to monitor.

5 AC power switch (rear panel) (page 11)

Set to the I (on) position.

If you are using DC power or a battery pack, connect the DC power or mount the battery pack on the battery pack shoe before playback.

6 COUNTER SEL button (page 13)

Select the data (elapsed playback time, time code value or user bit data) to be displayed in the time data display.

When displaying the time code value, select TC or VITC with extended menu item 629 “TC SELECT.”

Adjusting video processing parameters

You can adjust the following video processing parameters.

- Video output level
- Chroma output level
- Setup/black level
- Chroma phase
- Output signal sync phase
- Output signal subcarrier phase

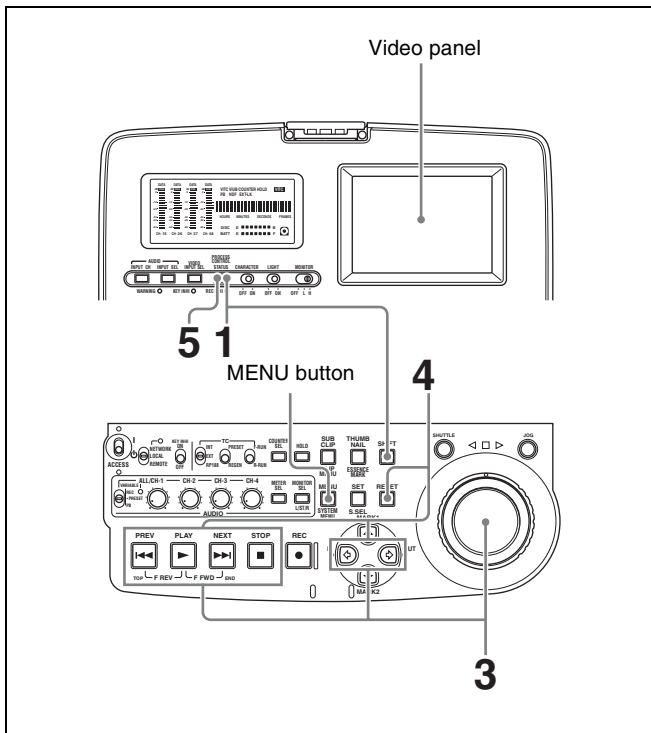

1 With the **SHIFT** button held down, press the **STATUS** button.

The process control screen ¹⁾ appears in the video panel.

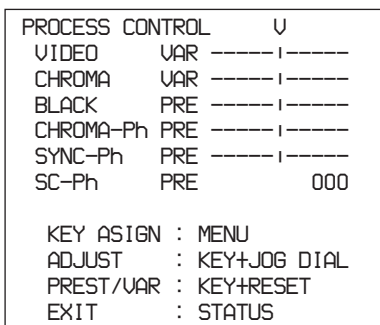

1) When the line mode is 525(U)/525(J), SETUP appears instead of BLACK.

Notes

- Do the following operations within 30 seconds. The screen returns to the normal screen if no operation is done for 30 seconds.
- The process control screen does not appear if either of the following is true.
 - The unit is being controlled from a device connected to the REMOTE connector, and basic menu item 006 “LOCAL FUNCTION ENABLE” is set to “dis” or “st&ej.”
 - The unit is connected to a computer by FAM or FTP, and the computer is logged in to this unit.

To check the assignments to buttons which select parameters

A list of button assignments appears at the bottom of the screen when you keep the MENU button pressed.

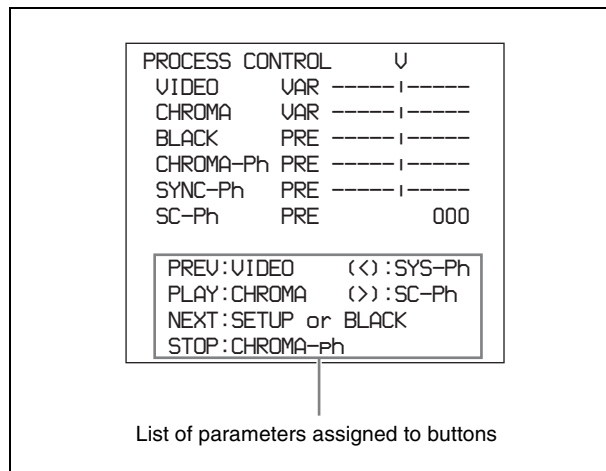

2 Hold down the following buttons and press the **RESET** button to select “PRE” (PRESET: factory preset setting) or “VAR” (VARIABLE: adjustable setting). Each press of the button switches between “PRE” and “VAR.”

Button	Parameter	Adjustment range ^{a)}
PREV	Video output level	-512 to <u>Q</u> to 511
PLAY	Chroma output level	-512 to <u>Q</u> to 511
NEXT	Setup/black level	-512 to <u>Q</u> to 511
STOP	Chroma phase	-128 to <u>Q</u> to 127
⇐	Output signal sync phase	-128 to <u>Q</u> to 127
⇒	Output signal subcarrier phase	<u>Q</u> to 511

a) Underlined values are the factory defaults.

The figure below is an example of the screen that appears when you hold the PLAY button down.

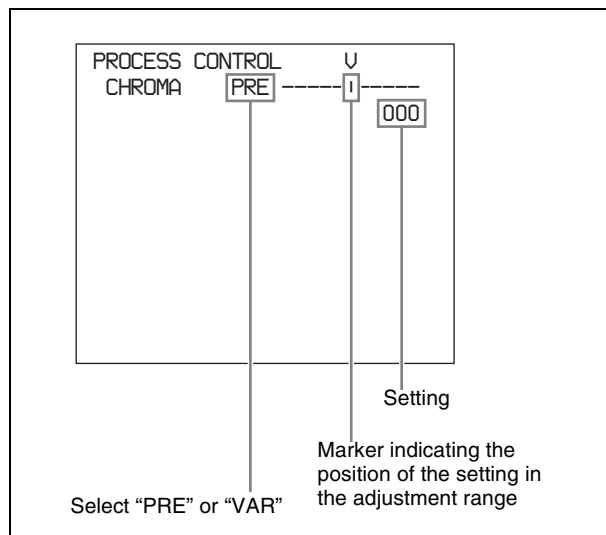

- 3** If you selected “VAR” in step 2, set the parameter value by holding down the corresponding button and rotating the jog dial, while viewing the video.

Setting values vary with the rotation speed of the jog dial.

- 4** Repeat steps 2 and 3 as required to set other parameters.
- 5** Press the STATUS button to return to the normal screen.

4-2-2 Playback Operation

This section describes the following types of playback:

- Normal playback
Playback at normal (± 1) speed
- Playback in jog mode
Variable speed playback, with the speed determined by the speed of turning the jog dial
- Playback in shuttle mode
Variable speed playback, with the speed determined by the angular position of the shuttle dial

Normal playback

First insert a disc.

For details of how to insert a disc, see 3-6-4 “Loading and Unloading a Disc” on page 38.

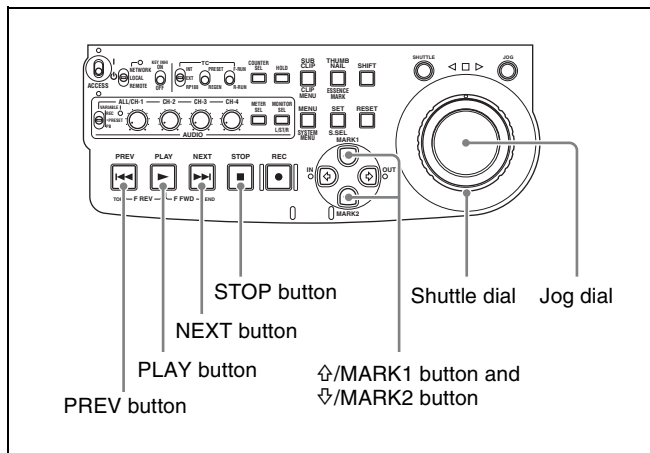

To start playback

Press the PLAY button.

Playback starts.

When two or more clips are recorded on the disc, they are played back continuously.

Note

No audio is output when non-audio signals are played back.

To jump to the next or previous clip, then start playback

Use the PREV button, NEXT button, jog dial, or shuttle dial.

For information about the functions of these buttons, see “5 Recording and playback control section” on page 16. For details of the jog and shuttle dials, see “3 Jog/shuttle control block” on page 14.

To stop playback

Press the STOP button.

If you play back to the end of the last clip

Playback automatically stops.

If, in this state, you press the PLAY button, the message “ALARM DISC END.” appears on the monitor.

To carry out playback again, move back to the desired clip using the PREV button, jog dial or shuttle dial.

To record an essence mark

While playing back a disc, you can record essence marks such as shot mark 1 and shot mark 2 in desired frames.

To record a shot mark 1 or shot mark 2, hold down the \curvearrowright /MARK1 or \curvearrowleft /MARK2 button and press the SET button.

Note

To erase or change essence marks, use the supplied PDZ-1 Proxy Browsing Software.

Playback in jog mode

In jog mode, you can control the speed of playback by the speed of turning the jog dial. The playback speed range is ± 1 times normal speed.

To carry out playback in jog mode, proceed as follows.

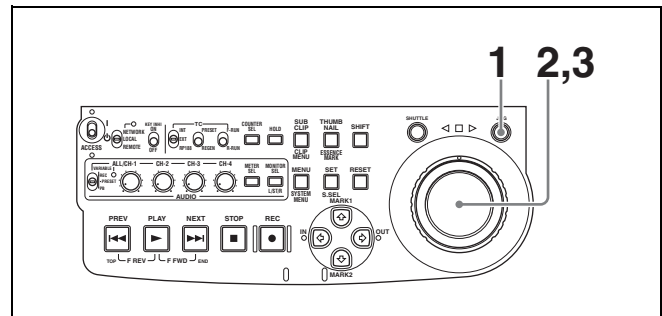

- 1** Press the JOG button, turning it on.
- 2** Turn the jog dial in the desired direction, at the speed corresponding to the desired playback speed.
Playback in jog mode starts.
- 3** To stop playback in jog mode, stop turning the jog dial.

When extended menu item 101 “SELECTION FOR SEARCH DIAL ENABLE” is set to “dial” (factory default

setting), just turning the jog dial with the JOG button off starts playback in jog mode.

Playback in shuttle mode

In shuttle mode, you can control the speed of playback by the angular position of the shuttle dial. The range of playback speed is ± 20 times normal speed. To carry out playback in shuttle mode, proceed as follows.

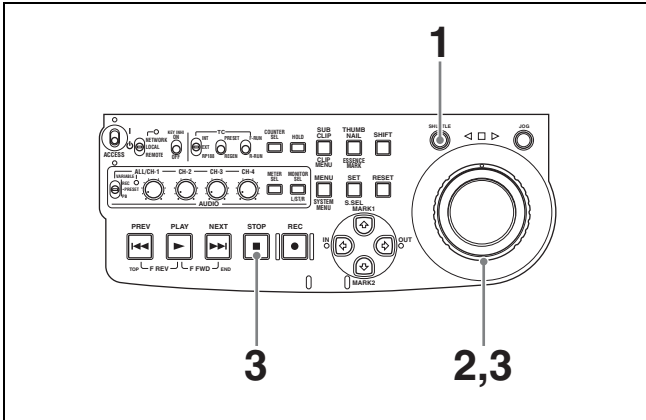

- 1 Press the SHUTTLE button, turning it on.
- 2 Turn the shuttle dial to the desired angle corresponding to the desired playback speed.
Playback in shuttle mode starts.
- 3 To stop playback in shuttle mode, return the shuttle dial to the center position, or press the STOP button.

When extended menu item 101 “SELECTION FOR SEARCH DIAL ENABLE” is set to “dial” (factory default setting), just turning the shuttle dial with the SHUTTLE button off starts playback in shuttle mode.

To alternate between normal-speed playback and shuttle mode playback

Set the shuttle dial to the position corresponding to the desired shuttle playback speed, then switch between normal-speed playback and shuttle playback by pressing the PLAY and SHUTTLE buttons alternately. For intermittent shuttle mode playback, press the STOP and SHUTTLE buttons alternately.

4-2-3 Thumbnail Search

Cuing up a desired clip

To display the thumbnail images of all clips on the disc, and cue up a desired clip, proceed as follows.

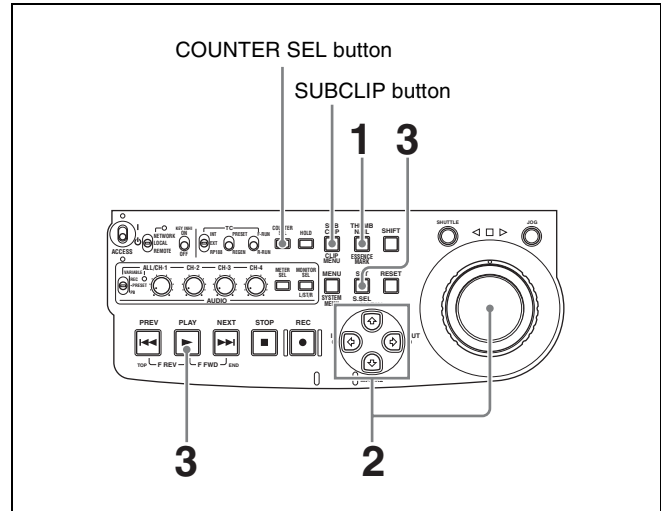

- 1 With the SUBCLIP button off, press the THUMB button, turning it on.
The thumbnails of clips on the disc appear.

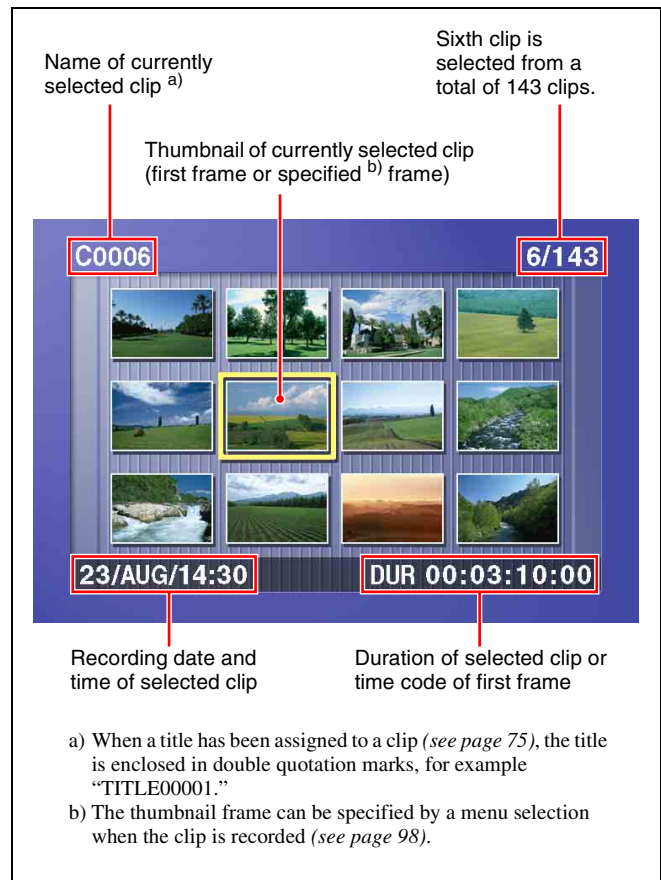

To switch between duration and time code display in the thumbnail display

Press the COUNTER SEL button. Each press of the button toggles between duration display and time code display.

To escape from the thumbnail display to the full-screen display

Press the THUMBNAIL button, turning it off.

- Use the arrow buttons or the jog dial to select the desired clip.

You can select clips with the following operations.

Press the PREV or NEXT button: Move to the previous or next clip.

Press the PREV or NEXT button with the SHIFT button held down: Move to the first or last clip.

Press the \uparrow or \downarrow button with the SHIFT button held down: Switch to the previous or next page.

- To cue up the selected clip, press the SET button. To start playback from the selected clip, press the PLAY button.

Cuing up a frame including an essence mark

Proceed as follows.

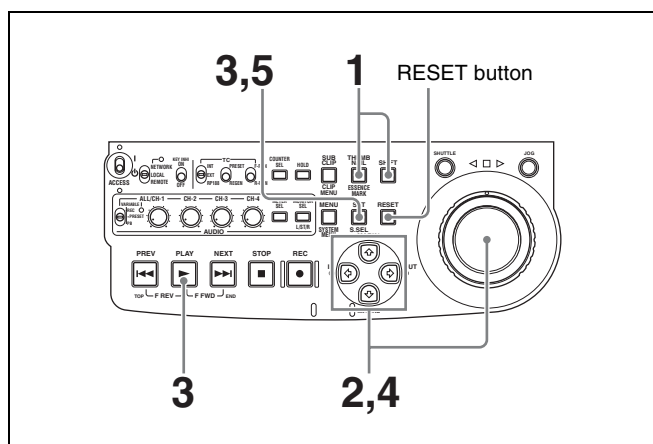

- Hold down the SHIFT button, and press the THUMBNAIL button, turning it on.

The essence mark selection screen appears.



To escape from the essence mark selection screen to the previous screen

Press the RESET button.

- Use the arrow buttons or the jog dial to select the desired essence mark.

You can select essence marks with the following operations.

Press the PREV or NEXT button: Move to the previous or next essence mark.

- Press the SET button.

Thumbnails of the frames including the selected essence mark appear.

(The example shows the case where SHOTMARK1 is selected as the essence mark.)

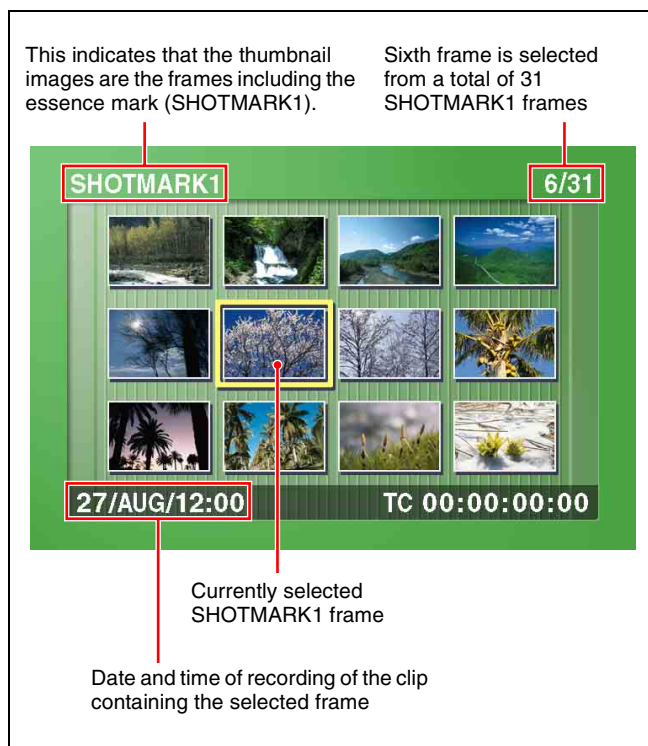

- Use the arrow buttons or the jog dial to select the desired frame.

You can select frames with the following operations.

Press the PREV or NEXT button: Move to the previous or next frame.

Press the PREV or NEXT button with the SHIFT button held down: Move to the first or last frame.

Press the \uparrow or \downarrow button with the SHIFT button held down: Switch to the previous or next page.

- Press the SET button to cue up the selected clip.

To start playback from the selected frame, press the PLAY button.

4-2-4 Clip List Playback

You can play back clips in the order of clip lists created with the scene selection function (see page 58).

Playing back in clip list order

Proceed as follows.

- 1 If the clip list that you want to play exists on the disc, load it into the current clip list.

About the current clip list, see page 60.

For the clip list loading operation, see 5-3-1 “Loading a Clip List From Disc Into Unit Memory” (page 68).

- 2 Press the SUBCLIP button, turning it on.

- 3 Press the PLAY button.

Playback begins from the first sub clip in the current clip list.

Note

Depending on the length of sub clips in the clip list and their arrangement on the disc, playback may freeze momentarily between sub clips.

Cuing up with sub clip thumbnails

With the desired clip list loaded in the current clip list, proceed as follows.

- 1 Press the SUBCLIP button and the THUMBNAIL button, turning them on.

Thumbnails of the first frames in the sub clips appear.

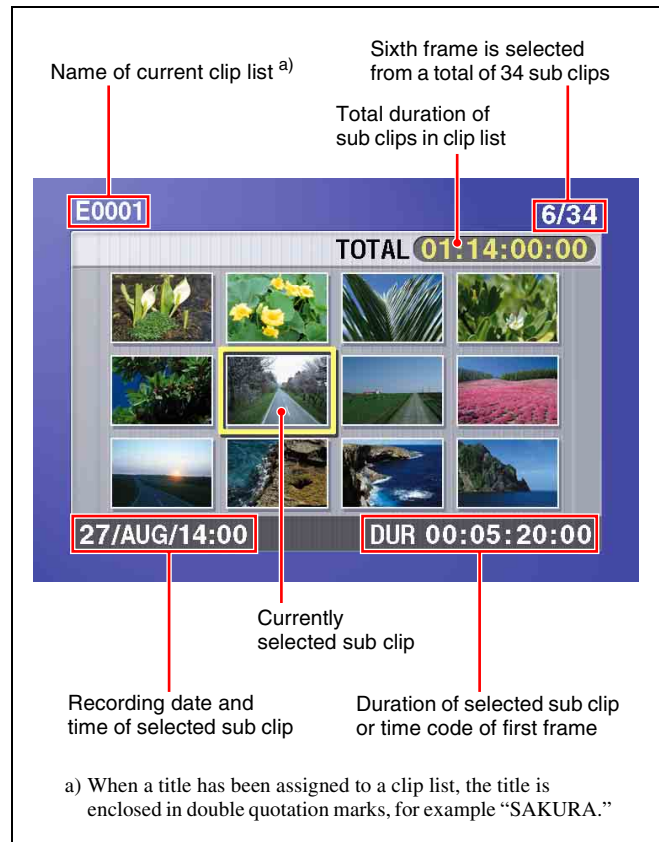

To switch between duration and time code display in the thumbnail display

Press the COUNTER SEL button. Each press of the button toggles between duration display and time code display.

To escape from the thumbnail display to the full-screen display

Press the THUMBNAIL button, turning it off.

- 2 Use the arrow buttons or the jog dial to select the sub clip you want to cue up.

You can select sub clips with the following operations.

Press the PREV or NEXT button: Move to the previous or next sub clip.

Press the PREV or NEXT button with the SHIFT button held down: Move to the first or last sub clip.

Press the ⬅ or ➡ button with the SHIFT button held down: Switch to the previous or next page.

- 3 To cue up the selected sub clip, press the SET button. To start playback from the selected sub clip, press the PLAY button.

4-2-5 Repeat Playback

You can perform repeat playback for normal and clip list playback.

To perform repeat playback, set extended menu item 142 “REPEAT MODE” to “play,” and then proceed as follows.

- 1 Insert a disc.
To perform repeat playback for normal playback, proceed to step 3.
- 2 To perform repeat playback for clip list playback, press the SUBCLIP button.
- 3 Press the PLAY button.

Playback starts from the saved playback position.

Normal playback: When playback of the last clip finishes, it resumes from the start of the disc, repeatedly playing from the first through the last clip on the disc.

Clip list playback: When playback of the last sub clip finishes, it resumes from the start of the clip list, repeatedly playing from the first through the last sub clip in the clip list.

If extended menu item 142 “REPEAT MODE” is set to “play,” repeat playback starts from the first clip automatically whenever you power the unit on with a disc loaded. Clip list playback starts from the first sub clip in the clip list.

To start repeat playback from the device connected to the REMOTE connector

Set extended menu item 142 “REPEAT MODE” to “play,” and then send a repeat playback command from the external device.

For details of commands, refer to REMOTE (9-pin) Protocol Manual for the PDW series.

To stop repeat playback

Do one of the following.

- Operate any of the playback buttons except the PLAY button, or operate the jog or shuttle dial.
- From the external device connected to the REMOTE connector on this unit, send a command other than the repeat playback start command to this unit.

The unit executes the operation for the button press, jog or search dial operation, or remote command that stops playback. (The unit enters search mode when you conduct a search, and stop mode at the end of the disc.)

To disable repeat playback

Set extended menu item 142 “REPEAT MODE” to “off.”

4-2-6 Locking and Deleting Clips

In the thumbnail screen, you can delete selected clips or lock them so that they cannot be deleted.¹⁾

1) This is supported from firmware version 1.5.

Locking clips

Locking prevents the following operations on clips.

- Deletion
- Renaming by FAM or FTP

Notes

- Locked clips are erased along with other clips when you format a disc.
- Clips cannot be locked or unlocked when the Write Inhibit tab of the disc is set to the recording disabled position, or when extended menu item 310 “REC INHIBIT” is set to “on.”

- 1 With the SUBCLIP button off, press the THUMBNAIL button, turning it on.

The thumbnails of the clips on the disc appear.

- 2 Use the arrow buttons or the jog dial to select the clip to lock.

You can select clips with the following operations.

Press the PREV or NEXT button: Move to the previous or next clip.

Press the PREV or NEXT button with the SHIFT button held down: Move to the first or last clip.

Press the \triangle/∇ button with the SHIFT button held down: Switch to the previous or next page.

- 3 With the SHIFT button held down, press the SUBCLIP button. Or press the MENU button.

The THUMBNAIL MENU appears.



To escape from the THUMBNAIL MENU to the previous screen

Press the RESET button.

- 4 With LOCK/UNLOCK CLIP selected, press the SET button.

You return to the thumbnail screen, and a lock icon appears on the thumbnail of the selected clip to show that it is locked.

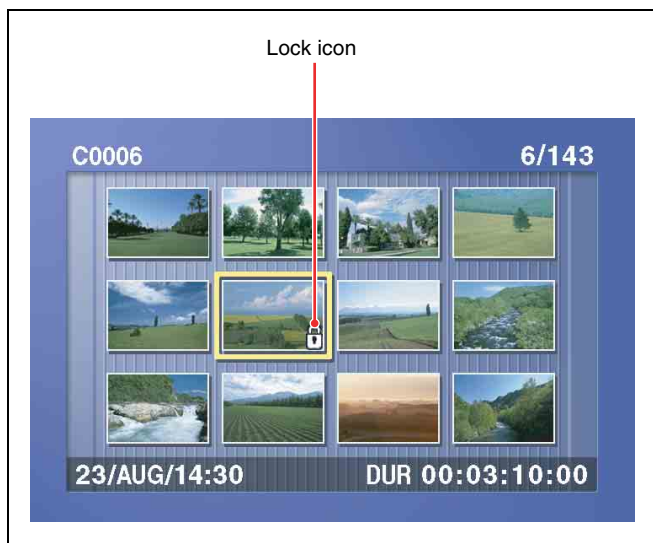

Locked clips cannot be deleted or renamed. Unlock the clip if you want to perform any of these operations.

To lock clips without displaying the THUMBNAIL MENU

After carrying out step 2 in the procedure, press the STOP button with the SHIFT button held down (shortcut operation).

To unlock clips

Carry out step 2 of “Locking clips” to select a locked clip (one with the lock icon displayed on its thumbnail). Then do one of the following.

- Carry out steps 3 and 4 of “Locking clips.”
- Press the STOP button with the SHIFT button held down (shortcut operation).

To lock all clips

- 1 Carry out steps 1 and 3 of “Locking clips” to display the THUMBNAIL MENU.
- 2 Use the arrow buttons or the jog dial to select LOCK ALL CLIPS, and then press the SET button.

A confirmation screen appears.

To cancel the lock operation and return to the thumbnail screen

Do one of the following.

- Use the ← or → button to select “CANCEL,” and then press the SET button.
 - Press the RESET button.
- 3 Use the ← or → button to select “OK,” and then press the SET button.

All clips are locked, and you return to the thumbnail screen.

To unlock all clips

Carry out the procedure in “To lock all clips,” selecting UNLOCK ALL CLIPS in step 2.

Deleting clips

Notes

- Clips cannot be deleted when the Write Inhibit tab of the disc is set to the recording disabled position, or when extended menu item 310 “REC INHIBIT” is set to “on.”
- Locked clips cannot be deleted.
- When the target clip is referenced in a clip list, the clip list that references the clip will also be deleted.

You can use the DISC MENU to delete the last clip or all clips. For details, see page 118.

- 1 With the SUBCLIP button off, press the THUMBNAIL button, turning it on.
The thumbnails of the clips on the disc appear.
- 2 Use the arrow buttons or the jog dial to select the clip to delete.

You can select clips with the following operations.

Press the PREV or NEXT button: Move to the previous or next clip.

Press the PREV or NEXT button with the SHIFT button held down: Move to the first or last clip.

Press the ⇐/⇒ button with the SHIFT button held down: Switch to the previous or next page.

- 3 With the SHIFT button held down, press the SUBCLIP button. Or press the MENU button.

The THUMBNAIL MENU appears (*see step 3 of “Locking clips” (page 55)*).

To escape from the THUMBNAIL MENU to the previous screen

Press the RESET button.

- 4 Use the arrow buttons or the jog dial to select DELETE CLIP, and then press the SET button.

Thumbnails of four frames in the target clip appear.

One of the following messages appears in a confirmation dialog, depending on whether the target clip is referenced in a clip list.

When the target clip is not referenced in a clip list: “DELETE CLIP?”

When the target clip is referenced in a clip list:

“DELETE CLIP & CLIP LIST?” (The clip list that references the clip will also be deleted.)



To go to the clip deletion screen without displaying the THUMBNAIL MENU

After step 2, press the RESET button with the SHIFT button held down (shortcut operation).

To cancel the deletion and return to the thumbnail screen

Do one of the following.

- Use the ⬆ or ⬇ button to select “CANCEL,” and then press the SET button.
- Press the RESET button.

- 5** Use the ⬆ or ⬇ button to select “OK,” and then press the SET button.

The clip is deleted and you return to the thumbnail screen.

To delete all clips

- 1** Carry out steps 1 and 3 of “Deleting clips” to display the THUMBNAIL MENU.
- 2** Use the arrow buttons or the jog dial to select DELETE ALL CLIPS, and then press the SET button.

A confirmation screen appears.

To cancel the deletion and return to the thumbnail screen

Do one of the following.

- Use the ⬆ or ⬇ button to select “CANCEL,” and then press the SET button.
- Press the RESET button.

- 3** Use the ⬆ or ⬇ button to select “OK,” and then press the SET button.

All clips are deleted, and you return to the thumbnail screen.

5-1 Overview

What is scene selection?

Scene selection is a function which allows you to select material (clips) from the material recorded on a disc and perform cut editing. You can do this by operating on this unit only.

- Scene selection is a convenient way to perform cut editing in the field and in other offline situations.
- Clip lists (edit data) created with the scene selection function can be used on XPRI and other full-feature nonlinear editing systems.

Flow of scene selection editing

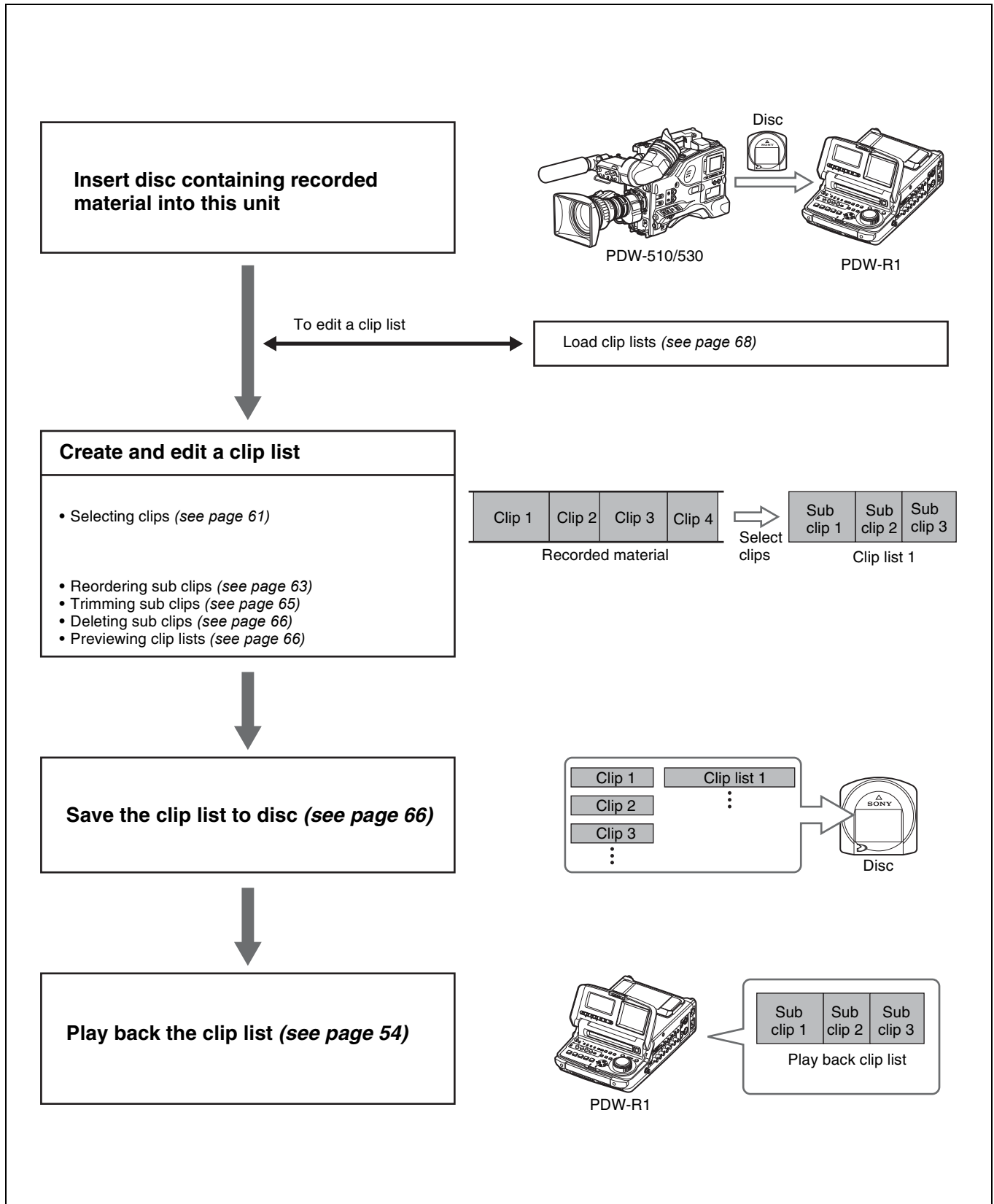

Clips

Material recorded on a disc with this unit is managed in units called “clips.” A clip contains the material between a recording start point (In point) and a recording end point (Out point).

Clips have names beginning with “C” for example “C0001.”

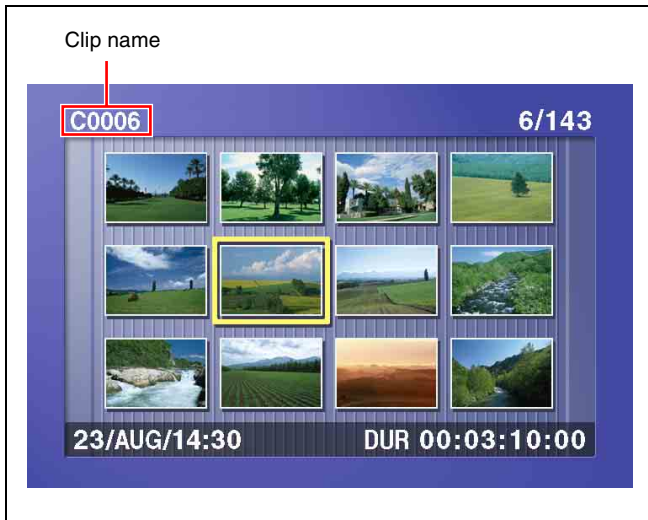
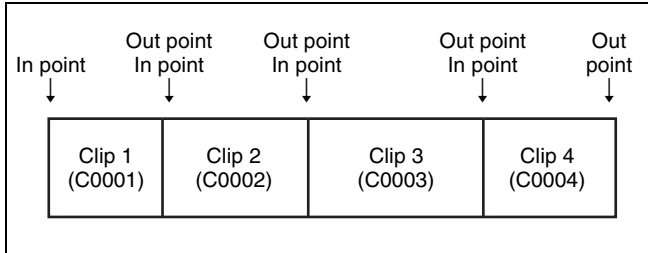

Clip lists

Data called a “clip list” is created when you use the scene selection function to select desired clips from the clips stored on a disc.

Clip lists have names beginning with “E” for example “E0001.” You can save up to 99 clip lists on a disc.

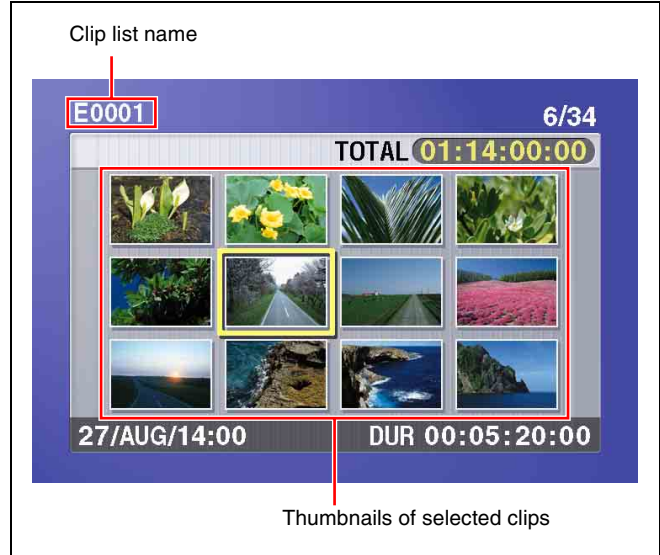

Sub clips (clips in clip lists)

The specified clips (or parts of clips) in a clip list are called “sub clips.” Sub clips are virtual data specifying ranges in the original clips. Clip data in the original clips is not overwritten.

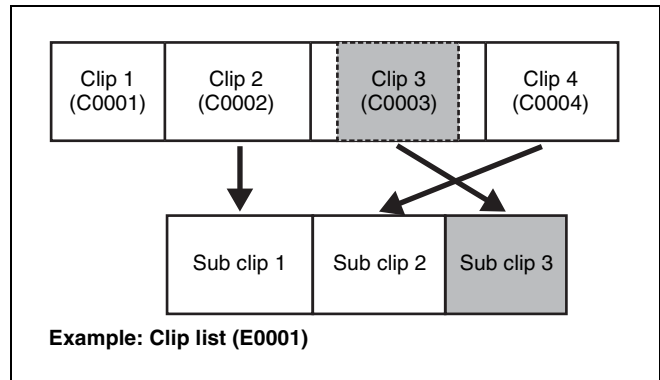

Clip list editing (current clip list)

Clip lists cannot be edited on disc. To edit clip lists, you need to load them, one at a time, into the unit memory. The clip list which is currently loaded into the unit memory is called the “current clip list.”

The current clip list is always the target of sub clip creation and editing. Clip list playback also uses the current clip list.

After creating and editing a clip list, you need to save it to disc.

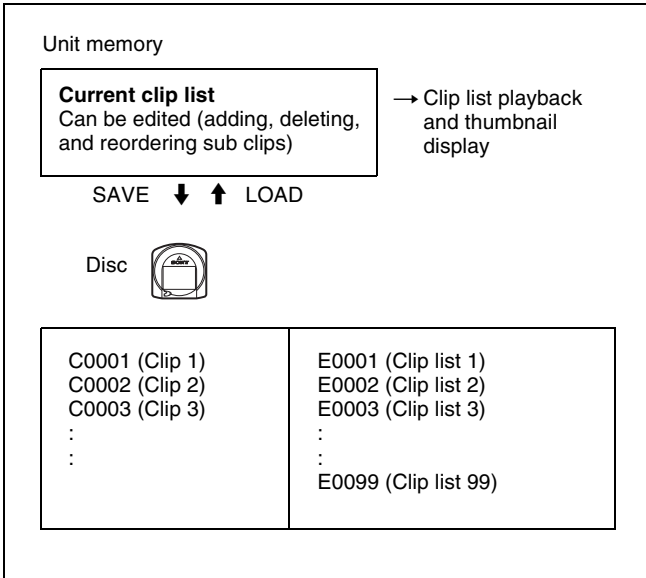

Clip list playback

Clips and clip lists are saved together on a disc.
Clips are played back according to clip list data.

5-2 Creating Clip Lists

Before starting

Insert a disc containing recorded clips into the unit.

5-2-1 Selecting Clips

There are two ways to select clips.

- Select from the thumbnail screen.
You can select the desired clips from the thumbnail screen.
- Select while playing back or searching.
You can select the scene to use while viewing the video.

The clips selected here are added to the current clip list as sub clips.

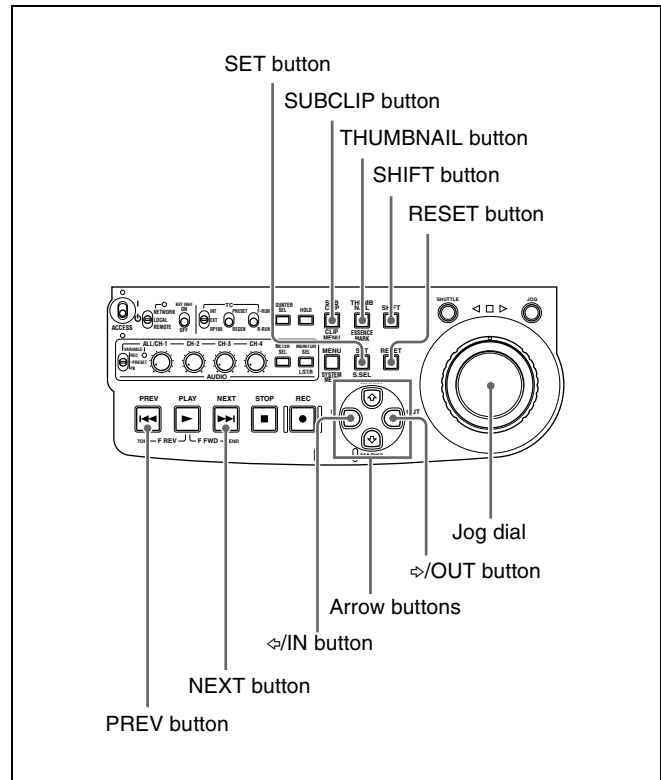

To select from the thumbnail screen

- 1 With the SUBCLIP button off, press the THUMBNAIL button, turning it on.

Thumbnails of the clips on the disc appear.



- 2 Use the arrow buttons or the jog dial to select the desired clip.

You can also select clips with the following operations.

Press the PREV or NEXT button: Moves to the previous or next clip.

Press the PREV or NEXT button with the SHIFT button held down: Moves to the first or last clip.

Press the ⬅ or ➡ button with the SHIFT button held down: Switches to the previous or next page. (Does not switch when there is only one page.)

- 3 With the SHIFT button held down, press the SET button.

The scene selection window appears.



To return to the original screen

Press the RESET button.

- 4 Press the SET button.

The selected clip is added to the current clip list as a sub clip.

At the same time, the scene selection window closes and you return to the original thumbnail screen.

- 5 Repeat steps 2 to 4 until you have added all of the desired clips to the current clip list.

You can select the same clip any number of times.

The scene selection window displays thumbnails of the sub clips that have been added to the current clip list. The cursor in the window indicates the position where the next sub clip will be added.

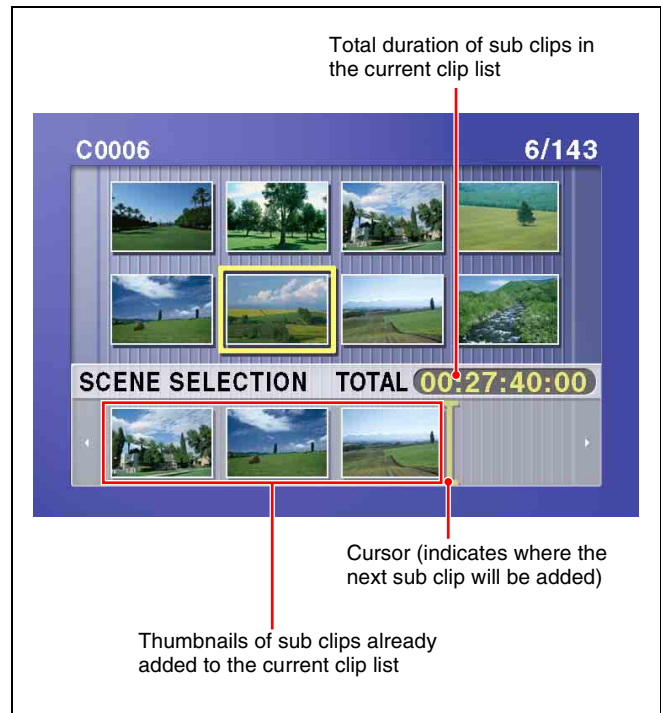

To move the cursor in the scene selection window

After carrying out step 3 to display the scene selection window, press the ⬅ or ➡ button.

- 6 When you have finished selecting all the clips you want, save the current clip list to disc.

See 5-2-6 “Saving the Current Clip List to Disc” (page 66).

To select while playing back and searching (quick scene selection)

- 1 With the SUBCLIP button off, and the clip displayed in full-screen mode, play back the clip or conduct a search to find the point that you want to set as the In point.

To display the desired clip in full-screen mode

If the thumbnail screen is displayed, use the arrow buttons or jog dial to select the clip to display in full-screen mode, and then press the SET button.



To search

Use the jog and shuttle dials.

- At the point you want to set as the In point, hold down the ⇐/IN button and press the SET button.

An In point is set, and the IN indicator lights.

- In the same way, search for the point you want to set as the Out point, and then hold down the ⇒/OUT button and press the SET button.

An Out point is set, and the OUT indicator lights.

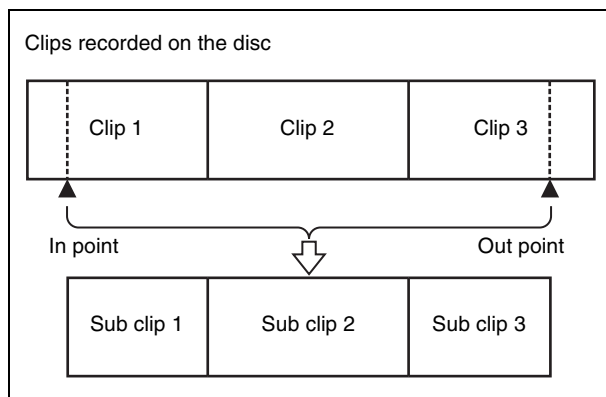

To check the duration

Press the ⇐/IN button and the ⇒/OUT button at the same time.

The duration appears on the screen.

To reset an In point or Out point

With the ⇐/IN button or ⇒/OUT button held down, press the RESET button.

- With the SHIFT button held down, press the SET button.

The section between the In point and Out point is added to the end of the current clip list as a sub clip.

When you set In and Out points stretching across several clips

One sub clip is created for each of the clips.

- Repeat steps 1 to 4 until you have added all of the clips you want to the current clip list.

- Save the current clip list to disc.

See 5-2-6 “Saving the Current Clip List to Disc” (page 66).

5-2-2 Reordering Sub Clips

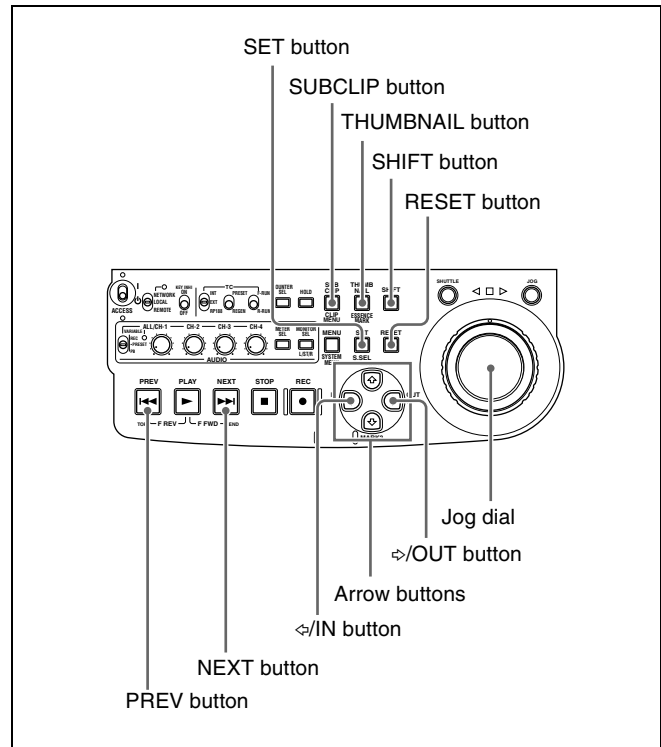

- Press the SUBCLIP button, turning it on.
- Press the THUMBNAIL button, turning it on.

Thumbnails of the sub clips in the current clip list appear.



If the clip list you want to edit is not the current clip list

Load the clip list from the disc into the unit memory (see page 68).

To return to the full-screen display

Press the THUMBNAIL button, turning it on.

- 3 Use the arrow buttons or the jog dial to select the desired sub clip.

You can also select sub clips with the following operations.

Press the PREV or NEXT button: Moves to the previous or next sub clip.

Press the PREV or NEXT button with the SHIFT button held down: Moves to the first or last sub clip.

Press the \uparrow or \downarrow button with the SHIFT button held down: Switches to the previous or next page. (Does not switch when there is only one page.)

- 4 With the SHIFT button held down, press the SET button.

The sub clip operation menu appears.



To return to the thumbnail screen without moving the sub clip

Do one of the following.

- Press the \uparrow or \downarrow button to select EXIT, and then press the SET button.
- Press the RESET button.

- 5 Use the \uparrow or \downarrow button to select MOVE, and then press the SET button.

The sub clip movement screen appears. The clip selected in step 3 appears surrounded by a frame.

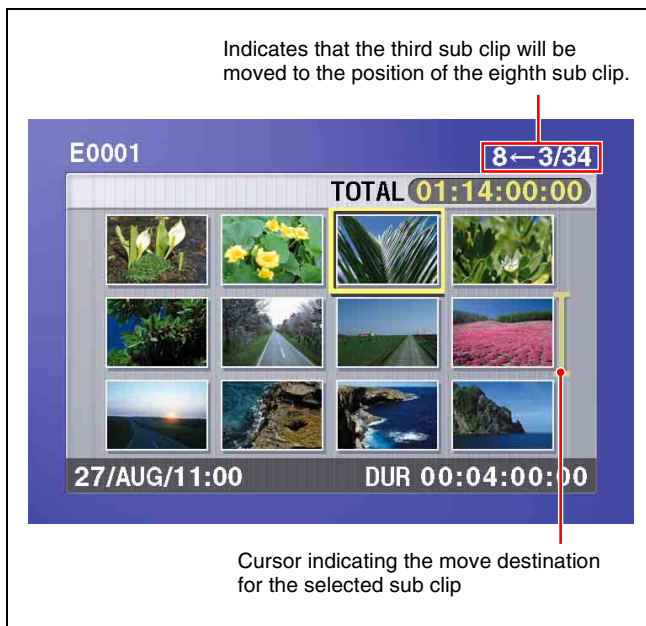

To return to the previous screen

Press the RESET button.

- 6 Use the arrow buttons or the jog dial to move the cursor to the position where you want to move the selected sub clip.

To return to the previous screen

Press the THUMBNAIL button.

- 7 Press the SET button.

The sub clip thumbnail screen appears, allowing you to check the results of the sub clip movement.



- 8 Save the current clip list to disc.

See 5-2-6 “Saving the Current Clip List to Disc” (page 66).

5-2-3 Trimming Sub Clips

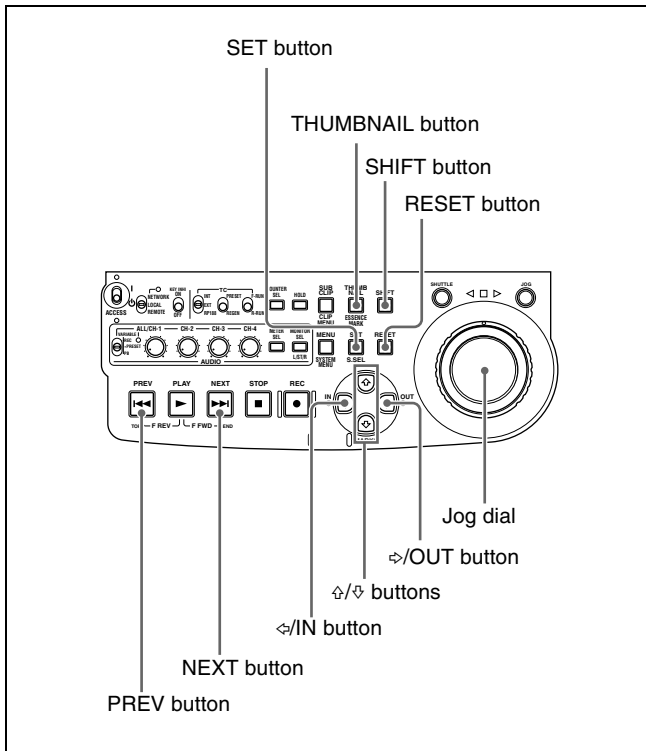

- 1 Carry out steps **1** to **4** of 5-2-2 “Reordering Sub Clips” to select a sub clip and display the sub clip operation menu.
- 2 Use the \updownarrow or $\leftarrow\rightarrow$ button to select TRIM, and then press the SET button.

The first frame of the selected sub clip appears. The first and last frames are set as provisional In and Out points, and the IN and OUT indicators light. In this state, you can play back and search the entire disc.

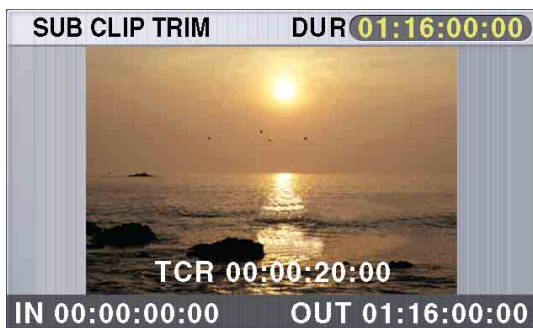

To cancel the trim and return to the previous screen

With the SHIFT button held down, press the SET button.

- 3 Play back and search the disc to find scenes to set new In and Out points.

- 4 At the scene where you want to set a new In or Out point, hold down the \leftarrow /IN button (to change the In point) or the \rightarrow /OUT button (to change the Out point) and press the SET button.

Depending on the button that you pressed, a new In or Out point is set.

To change both the In and Out points

Carry out steps **3** and **4** for both the In and Out points.

To reset the In or Out point

With the \leftarrow /IN button or \rightarrow /OUT button held down, press the RESET button. The In or Out point is restored to the value it had before the sub clip trim screen opened.

To cue up the In or Out point

With the \leftarrow /IN button held down, press the PREV button. Or with the \rightarrow /OUT button held down, press the NEXT button.

Note

You can escape from the sub clip trim screen to full-screen display without executing a trim if you press the THUMBNAIL button.

- 5 Once you have set the new In point or Out point, hold down the SHIFT button and press the SET button.

The trim is executed, and you return to the sub clip thumbnail display.



To cancel the trim

Reset the In or Out point to the value it had before you entered the sub clip trim screen, and then hold down the SHIFT button and press the SET button.

- 6 Save the current clip list to disc.

See 5-2-6 “Saving the Current Clip List to Disc” (page 66).

5-2-4 Deleting Sub Clips

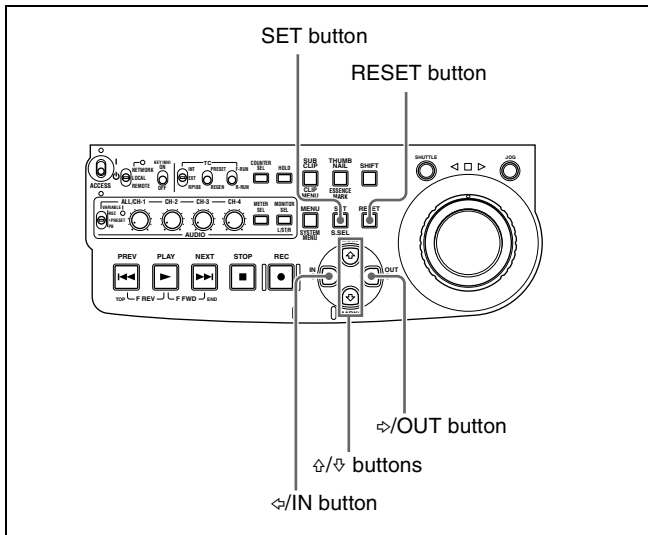

- 1 Carry out steps 1 to 4 of 5-2-2 “Reordering Sub Clips” to select a sub clip and display the sub clip operation menu.
- 2 Use the ⇐ or ⇨ button to select DELETE, and then press the SET button.

The sub clip deletion screen appears.

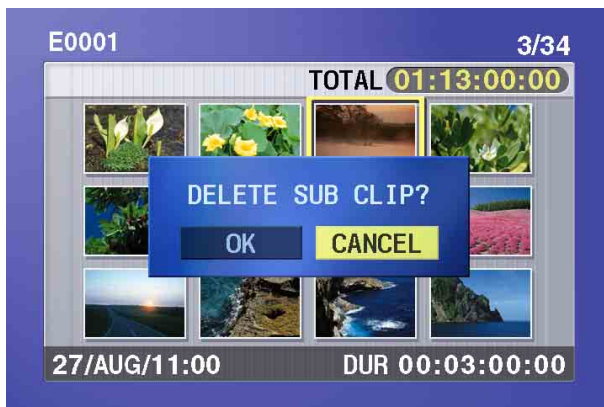

To cancel the deletion and return to the previous screen

Do one of the following

- Use the ⇐ or ⇨ button to select CANCEL, and then press the SET button.
- Press the RESET button.

The screen returns to the sub clip thumbnail display.

- 3 Use the ⇐ or ⇨ button to select OK, and then press the SET button.

The selected sub clip is deleted, and the screen returns to the sub clip thumbnail display.



- 4 Save the current clip list to disc.

See 5-2-6 “Saving the Current Clip List to Disc” (page 66).

5-2-5 Previewing the Current Clip List

Press the SUBCLIP button, turning it on, and then press the PLAY button.

When the THUMBNAIL button is lit, playback starts from the beginning of the selected sub clip.

When the THUMBNAIL button is not lit, playback starts from the first sub clip in the clip list.

5-2-6 Saving the Current Clip List to Disc

The current clip list is not saved to disc unless you carry out this procedure. After editing clip list data, you should always save it to disc.

Notes

- The current clip list is not saved to disc if the disc’s write protect tab is set to the recording disabled position.
- Unless you carry out this procedure, the unit does not enter the standby state even if you set the on/standby switch to the ⏻ position. Follow the message that appears and return the on/standby switch to the | side, and then save the clip list or, if you do not need it, clear it (see page 69).

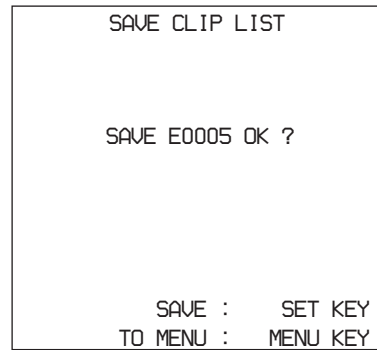
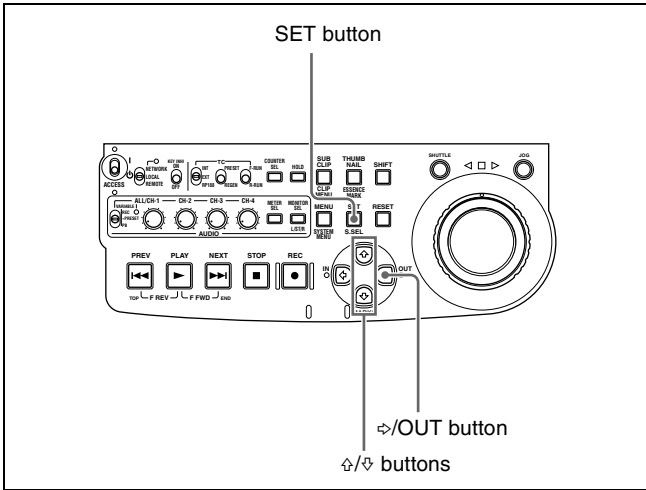

1 Display the CLIP menu.

See “To display the CLIP menu” (page 68).

2 Use the ⇧ or ⇩ button to move the cursor to SAVE, and then press the ⇨ button.

A list of clip lists appears.

“NEW FILE” is displayed for clip lists without any registered data.

The date of creation or the title is displayed for each clip list.

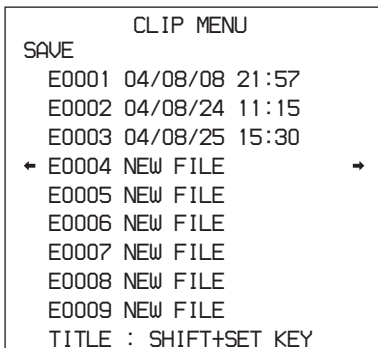

To switch between display of dates of creation, titles, and clip list names

With the SHIFT button held down, press the SET button.

With each press, the display changes as follows.

Dates of creation > titles > clip list names > dates of creation...

3 Use the ⇧ or ⇩ button or the jog dial to select the desired clip list, and then press the ⇨ button.

A confirmation message like the one shown below appears.

To cancel the save

Press the MENU button.

4 Press the SET button.

The current clip list is saved to disc.

To assign a title to a clip list

Use the supplied PDZ-1 Proxy Browsing Software.

For details, see the PDZ-1 online help.

5-3 Managing Clip Lists (CLIP Menu)

After you create a clip list, you can use the CLIP menu to save it to disc, load it from disc into the unit memory, and delete it from the disc.

The CLIP menu also allows you to clear and edit the current clip list.

Note

Carry out CLIP menu operations with the unit stopped. If the message “STOP ONCE, THEN EXECUTE.” appears, press the STOP button.

To display the CLIP menu

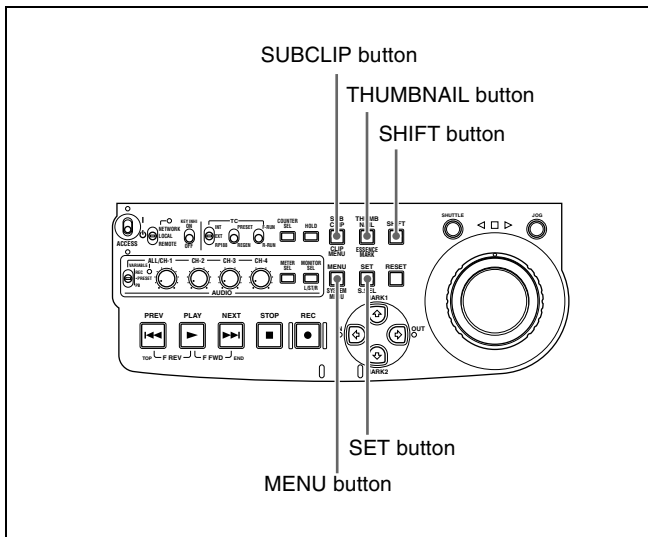

With the THUMBNAIL button off, hold down the SHIFT button and press the SUBCLIP button.

If the THUMBNAIL button is lit

Press the THUMBNAIL button to turn it off.

The CLIP menu appears.

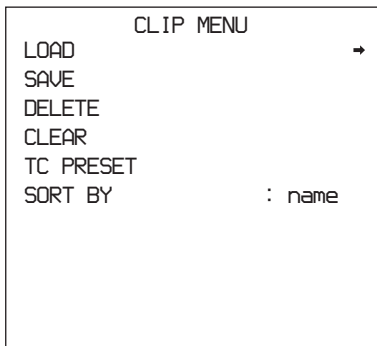

Item	Operation
LOAD	Load a clip list from the disc into the current clip list (see page 68)
SAVE	Save the current clip list to disc (see page 66)
DELETE	Delete a clip list from the disc (see page 69)
CLEAR	Clear the current clip list from the unit memory (see page 69)
TC PRESET	Preset the first time code in the current clip list (see page 69)
SORT BY	Sort clip lists by name or date of creation (see page 70)

To escape from the CLIP menu.

Press the MENU button.

5-3-1 Loading a Clip List From Disc Into Unit Memory

The clip list loaded with this procedure becomes the current clip list.

1 Display the CLIP menu.

See “To display the CLIP menu” (page 68).

2 Use the \uparrow button to move the cursor to LOAD, and then press the \Rightarrow button.

A list of clip lists appears.

The date of creation or the title is displayed for each clip list.

CLIP MENU	
LOAD	
E0001	04/08/08 21:57
E0002	04/08/24 11:15
E0003	04/08/25 15:30
\leftarrow E0004	NEW FILE \rightarrow
E0005	NEW FILE
E0006	NEW FILE
E0007	NEW FILE
E0008	NEW FILE
E0009	NEW FILE
TITLE : SHIFT+SET KEY	

To switch between display of dates of creation, titles, and clip list names

With the SHIFT button held down, press the SET button.

With each press, the display changes as follows.

Dates of creation > titles > clip list names > dates of creation...

- Use the \uparrow or \downarrow button or the jog dial to select the desired clip list, and then press the \rightarrow button

A confirmation message like the one shown below appears.

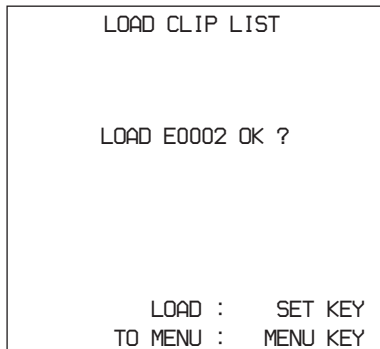

- Press the SET button.

The selected clip list is loaded into the unit memory as the current clip list.

If an unsaved current clip list exists in the unit memory

A warning message like the following appears.

“CLIP LIST IS NOT SAVED. OVERWRITE CLIP LIST?”

Press the SET button to overwrite the unsaved current clip list, or press the MENU button to quit without overwriting.

To display thumbnails of the sub clips in the newly loaded current clip list

Press the SUBCLIP button, and then press the THUMBNAIL button.

5-3-2 Deleting Clip Lists From a Disc

- Display the CLIP menu.

See “To display the CLIP menu” (page 68).

- Use the \uparrow or \downarrow button to move the cursor to DELETE, and then press the \rightarrow button.

A list of clip lists appears.

The date of creation or the title is displayed for each clip list. The date of creation is always displayed for clip lists without titles.

To switch between display of dates of creation, titles, and clip list names

With the SHIFT button held down, press the SET button.

With each press, the display changes as follows.

Dates of creation > titles > clip list names > dates of creation...

- Use the \uparrow or \downarrow button or the jog dial to select the desired clip list, and then press the \rightarrow button.

A confirmation message like the one shown below appears.



- Press the SET button.

The selected clip list is deleted from the disc.

5-3-3 Clearing the Current Clip List From the Unit Memory

This operation clears the current clip list, so that no clip list is loaded in the unit memory.

- Display the CLIP menu.

See “To display the CLIP menu” (page 68).

- Use the \uparrow or \downarrow button to move the cursor to CLEAR, and then press the \rightarrow button.

A message like the one shown below appears.

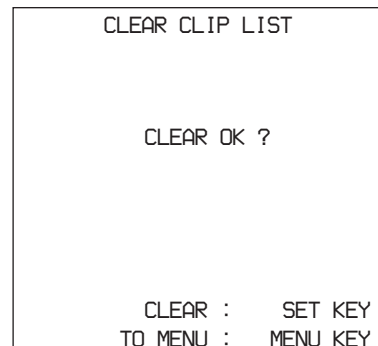

- Press the SET button.

The current clip list is cleared from the unit memory.

5-3-4 Presetting the Initial Time Code of the Current Clip List

When the unit is powered on, and when you insert a new disc, the initial time code of the current clip list is set to

“00:00.00.00.” You can set the initial time code to any value.

- 1 Load an existing clip list for which you want to set the initial time code into to the unit memory as the current clip list.

For details, see 5-3-1 “Loading a Clip List From Disc Into Unit Memory” (page 68).

- 2 Display the CLIP menu.

See “To display the CLIP menu” (page 68).

- 3 Use the ∇ button to select TC PRESET, and then press the \Rightarrow button.

A screen like the one shown below appears.

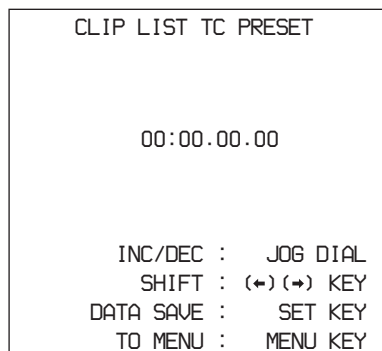

The time code shown in this screen is the current initial time code of the current clip list. If you have already set the initial time code for this clip list, that time code is displayed.

- 4 Repeat the following operations to set a time code value (LTC).
 - Press the \Leftarrow or \Rightarrow button to select the digit to replace.
 - Rotate the jog dial to set a value.
- 5 Press the SET button.

The initial time code (LTC) of the current clip list is set. When the clip list is played back, time code will start counting from that value.

To check the time code after setting it

Press the SUBCLIP button, turning it on. The initial time code of the current clip list appears in the TCR field.

- 6 Save the current clip list to disc.

See 5-2-6 “Saving the Current Clip List to Disc” (page 66).

5-3-5 Sorting Clip Lists

Proceed as follows to sort the existing clip lists by clip list name or by date of creation.

- 1 Display the CLIP menu.

See “To display the CLIP menu” (page 68).

- 2 Use the \uparrow or \downarrow button to select SORT BY, and then press the \Rightarrow button.

A screen like the one shown below appears.

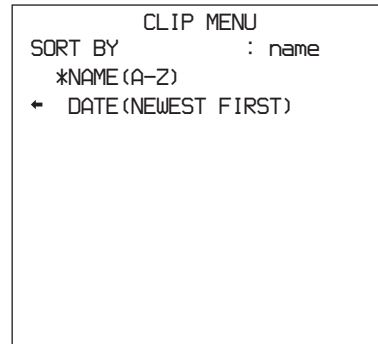

- 3 Use the \uparrow or \downarrow button to select NAME or DATE.

NAME: Sort in ascending order by clip list name (factory default setting).

DATE: Sort by date of creation, with the newest clip list first.

- 4 Press the \Leftarrow button to return to the CLIP menu screen.

The clip lists are sorted by the method you chose in step 3.

Unused clip lists are excluded from the sort.

5-4 Using PDZ-1 Proxy Browsing Software

When a computer with the PDZ-1 Proxy Browsing Software installed is connected to this unit, you can transfer the proxy AV data and metadata files recorded on a disc to the computer. On the computer side, PDZ-1 enables you to browse the proxy AV data, add or modify metadata (titles, comments, essence marks, etc.), or create a clip list. The modified metadata and the created clip list can then be written back to the disc loaded in this unit.

Live logging function

If you set extended menu item 258 “LIVE LOGGING” to “on,” you can use PDZ-1 to do the following during recording of high-resolution data: view proxy AV data, perform cut editing of the data, and enter metadata.

For more information about PDZ-1 functions and operations, refer to the PDZ-1 help.

System requirements

The following are required to use PDZ-1.

- Computer:
 - When using the live logging function:
PC with Intel Pentium 4 CPU, at least 2 GHz (installed memory: at least 512 MB)
 - When not using the live logging function:
PC with Intel Pentium III CPU, at least 1 GHz (installed memory: at least 512 MB)
- Operating system: Microsoft Windows 2000 Service Pack 4 or higher, or Microsoft Windows XP Professional Service Pack 1 or higher
- Web browser: Internet Explorer 6.0 Service Pack 1 or higher
- DirectX: DirectX 8.1b or higher

To install PDZ-1

Insert the supplied CD-ROM (PDZ-1 Proxy Browsing Software) in the CD-ROM drive of the computer and execute the Setup.exe file, then follow the installation instructions.

For details, refer to the ReadMe file contained on the CD-ROM disc.

Notes

- Make sure that the hard disk drive on which the work folder to store the material transferred from this unit has adequate free space. The amount of proxy AV data

transferred is about 1.4 GB per disc (when recording in the DVCAM format).

- To transfer files between the computer and this unit requires this unit’s IP address and other network-related settings to be made.

For details of the network-related settings, see “To change network settings” (page 115).

6-1 Overview

A remote computer can be connected to this unit and used to operate on recorded data which has been saved in data files, such as video and audio data files.

There are two ways to connect a remote computer.

- **FAM connection**
Connect the i.S400 (i.LINK) connector on this unit to the i.LINK (IEEE1394) connector on the remote computer, using an i.LINK cable (*see page 78*).
- **FTP connection**
Connect the network connectors on this unit and the remote computer, using a network cable (*see page 80*).

6-1-1 Directory Structure

The following figure shows the directory structure of discs visible to a remote computer.

Note

This structure is not the same as the actual structure recorded on the disc.

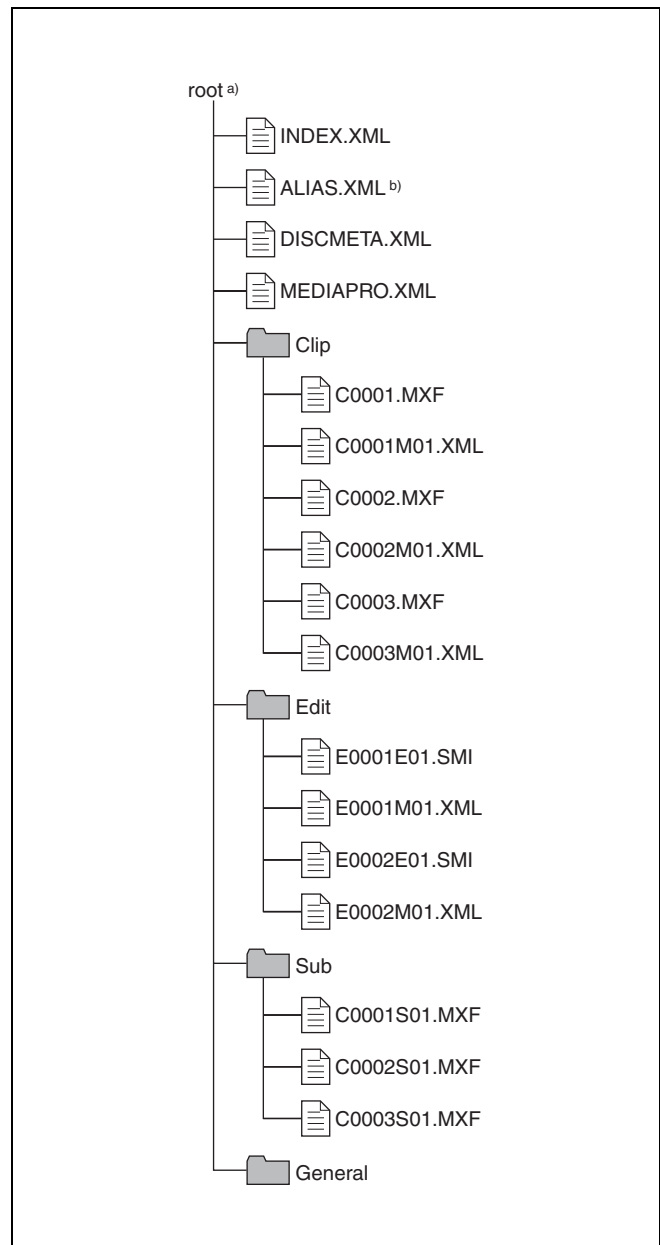

a) Root directory

b) Only when sub item "NAMING FORM" of basic menu item 036 is set to "free"

6-1-2 File Operation Restrictions

This section explains which operations are possible on files stored in each directory.

When required, the following operation tables distinguish reading and overwriting from partial reading and overwriting.

Read: Read data sequentially from the start to the end of the file.

Partial read: Read only a part of the data in the file.

Overwrite: Overwrite data sequentially from the start to the end of the file.

Partial overwrite: Overwrite data to a part of the file only.

Root directory

File name	Content	Operations				
		Read/ Partial read	Overwrite/ Partial overwrite	Rename	Create	Delete
INDEX.XML	Contains data for management of the audio/video material on the disc.	Yes	No	No	No	No
ALIAS.XML ^{a)}	Contains conversion tables for assigning user-defined names to clips and clip lists.	Yes	No	No	No	No
DISCMETA.XML	Contains metadata to indicate the disc properties.	Yes	Yes ^{b)}	No	No	No
MEDIAPRO.XML	Contains a list of audio/video material on the disc, basic properties, related information, and information about access methods.	Yes	No	No	No	No
Other files	Files other than the above	–	No	–	No	–

a) Only when sub item “NAMING FORM” of basic menu item 036 is set to “free”

b) Only files which can be overwritten by XDCAM

Notes

- Directories cannot be created in the root directory.
- The directories in the root directory (Clip, Edit, Sub, and General) cannot be deleted or renamed.

Clip directory

File name	Content	Operations				
		Read/ Partial read	Overwrite/ Partial overwrite	Rename	Create	Delete
C*.MXF ^{a)}	Clip file created by recording (MXF file) *: 0001 to 4999	Yes	No	No ^{b)}	Yes ^{c)}	Yes ^{d)}
C*M01.XML ^{a)}	Metadata file generated automatically when C*.MXF file is created. *: 0001 to 4999	Yes	Yes ^{e)}	No ^{f)}	No ^{g)}	No ^{h)}
Other files	Files other than the above	–	No	–	No	–

a) With firmware version 1.5 and higher, the unit can handle files with user-defined names in the “C*” part.

b) Possible with firmware version 1.5 and higher.

c) Only files which are 2 seconds or longer in length, in a format matching the line mode format (525/625) and recording format (IMX50/IMX40/IMX30/DVCAM) and number of audio channels of the recorded sections of the disc, and which can be overwritten by XDCAM.

d) Only when the write inhibit tab on the disc is set to enable recording, and when extended menu item 310 “REC INHIBIT” is set to “off.” With

firmware version 1.4x and lower, only the most recently recorded clip may be deleted. With firmware version 1.5 and higher, any clip may be selected and deleted.

e) Only files which can be overwritten by XDCAM

f) With firmware version 1.5 and higher, when the “C*” part of a C*.MXF file name is changed, a C*M01.XML with the same name in the “C*” part is also changed automatically.

g) When a C*.MXF file is created, a C*M01.XML file with the same name in the “C*” part is created automatically.

h) When a C*.MXF file is deleted, the C*M01.XML file with the same name in the “C*” part is also deleted automatically.

Notes

- Directories cannot be created in the Clip directory.
- When the following operations, supported by version 1.5 and higher XDCAM devices, are carried out on a disc, then it becomes impossible for version 1.4x and lower XDCAM devices to record new clips or delete existing

clips on that disc. (The only possible operations are playback and disc formatting.)

- Writing of clips with user-defined names
- Locking of clips
- Deletion of clips (except the last recorded clip)
- If you attempt to write a C*.MXF file which does not meet the conditions specified as remark c) on this table via a FAM connection, a Windows error message appears to the effect that the file or directory is corrupt and cannot be read.

Edit directory

File name	Content	Operations				
		Read/ Partial read	Overwrite/ Partial overwrite	Rename	Create	Delete
E*E01.SMI ^{a)}	Clip list file *: 0001 to 0099	Yes	Yes ^{b)}	No ^{c)}	Yes ^{d)}	Yes ^{e)}
E*M01.XML ^{a)}	Metadata file generated automatically when E*E01.SMI file is created. *: 0001 to 0099	Yes	Yes ^{b)}	No ^{f)}	No ^{g)}	No ^{h)}
Other files	Files other than the above	–	No	–	No	–

- a) With firmware version 1.5 and higher, the unit can handle files with user-defined names in the “E*E01” part.
- b) Only files which can be overwritten by XDCAM. Partial overwriting is not possible.
- c) Possible with firmware version 1.5 and higher.
- d) Only files which can be overwritten by XDCAM
- e) Only when the write inhibit tab on the disc is set to enable recording, and when extended menu item 310 “REC INHIBIT” is set to “off.”
- f) With firmware version 1.5 and higher, when the “E*E01” part of an E*E01.SMI file name is changed, an E*M01.XML file with the same name in the “E*” part is generated automatically.

- g) When an E*E01.SMI file is created, an E*M01.XML file with the same name in the “E*” part is created automatically.
- h) When an E*E01.SMI file is deleted, the E*M01.XML file with the same name in the “E*” part is also deleted automatically.

Note

Directories cannot be created in the Edit directory.

Sub directory

File name	Content	Operations				
		Read/ Partial read	Overwrite/ Partial overwrite	Rename	Create	Delete
C*S01.MXF ^{a)}	Proxy AV data (MXF) file generated automatically when a C*.MXF file is created. *: 0001 to 4999	Yes	No	No ^{b)}	No ^{c)}	No ^{d)}
Other files	Files other than the above	–	No	–	No	–

- a) With firmware version 1.5 and higher, the unit can handle files with user-defined names in the “C*” part.
- b) With firmware version 1.5 and higher, when the “C*” part of a C*.MXF file name is changed, a C*S01.MXF file with the same name in the “C*” part is generated automatically.
- c) When a C*.MXF file is created, a C*S01.XML file with the same name in the “C*” part is created automatically.
- d) When a C*.MXF file is deleted, the C*S01.XML file with the same name in the “C*” part is also deleted automatically.

Note

Directories cannot be created in the Sub directory.

General directory

File name	Content	Operations				
		Read/ Partial read	Overwrite/ Partial overwrite	Rename	Create	Delete
Any file		Yes	Yes	Yes ^{a)}	Yes	Yes ^{b)}

a) UTF-8 file names can be up to 63 bytes in length. (Depending on the character type, file names (including extension) may be limited to 21 characters.)

b) Only when the write inhibit tab on the disc is set to enable recording, and when extended menu item 310 "REC INHIBIT" is set to "off."

The following directory operations are possible in the General directory.

- Directory creation (up to 64 levels, including the General directory)
- Deletion and renaming of directories

Notes

- The maximum number of files which can be created on a disc, including directories, is 5,000.
- File names and directory names can use letters, numbers, and symbols from the Unicode 2.0 (UTF-8) character set. ¹⁾

However, the following control characters and symbols cannot be used.

- Control characters: U+0000 to U+001F, U+007F
- Symbols: ", *, /, :, <, >, ', ?, \, |

1) This is supported from firmware version 1.4. However, the following character codes cannot be used by FAM connections.
 U+010000, U+020000, U+030000, U+040000, U+050000, U+060000,
 U+070000, U+080000, U+090000, U+0A0000, U+0B0000, U+0C0000,
 U+0D0000, U+0E0000, U+0F0000, U+100000
 (There are no limits to characters which can be used by FTP connections.)

6-1-3 Assigning User-Defined Clip Titles

By default, clips on each disc are assigned names in the range C0001.MXF to C4999.MXF. For this reason, two discs can contain clips with the same names. The automatic title generation function allows you to assign titles to all of the clips on several discs, which facilitates clip management. For example, if the titles TITLE00001 to TITLE00020 are assigned to clips C0001.MXF to C0020.MXF on disc 1, then the titles TITLE00021 to TITLE00037 are assigned to clips C0001.MXF to C0017.MXF on disc 2.

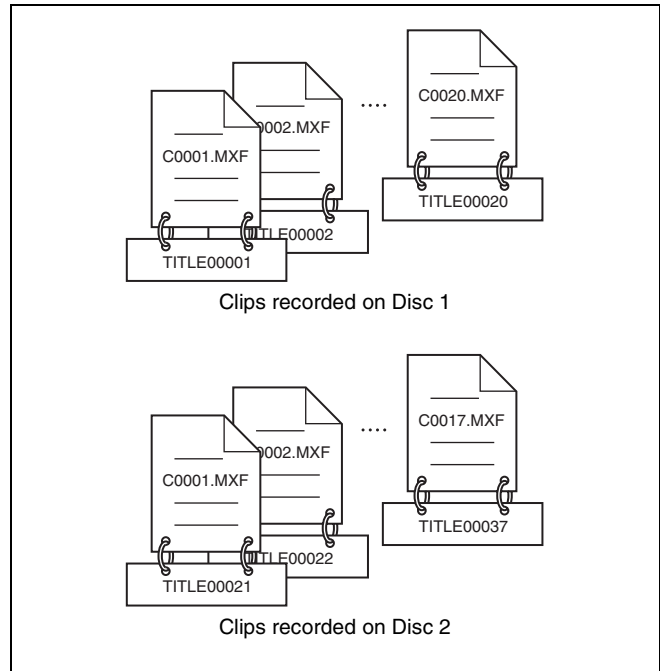

Proceed as follows to specify a title and assign it to recorded clips.

- 1 Press the MENU button.
- 2 Rotate the jog or shuttle dial to display menu item 035.
- 3 With the SHUTTLE button held down, rotate the jog or shuttle dial to select "on."
- 4 Press the SET button.

The clip title naming screen appears.

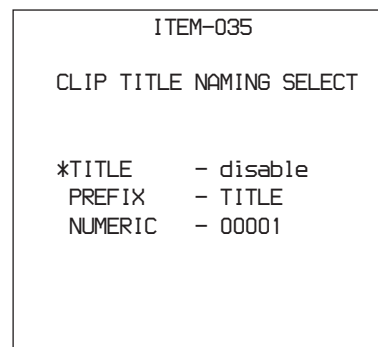

- 5** With the STOP button held down, rotate the jog or shuttle dial to move the asterisk (*) on the left of the menu items to “TITLE.”

The asterisk indicates the selected item.

- 6** With the SHUTTLE button held down, rotate the jog or shuttle dial to select “enable.”

The automatic title generation function is enabled.

- 7** With the STOP button held down, rotate the jog or shuttle dial to move the asterisk to the item that you want to set first.

PREFIX: A string of up to 10 characters. The allowable characters are alphanumeric characters, symbols (! # \$ % & ' () + , - . ; = @ [] ^ _ { } ~), and the space character.

NUMERIC: A five-digit number (00001 to 99999) to serve as the initial value of the serial number.

- 8** Rotate the jog or shuttle dial to select the character position to set.

- 9** With the SHUTTLE button held down, rotate the jog or shuttle dial to select the character to set.

- 10** Repeat steps **8** and **9** as required.

When you are setting the “NUMERIC” item, you can press the RESET button to return the initial value of the serial number to 00001 (factory default setting).

- 11** Carry out steps **7** to **10** to set the other item.

- 12** Press the SET button.

The title is saved.

To check the titles of recorded clips

Press the THUMBNAIL button to display the thumbnail screen, and select the clip whose title you want to check. The title of the selected clip appears at the upper left of the screen.

See “Cuing up a desired clip” (page 52) for more information about the thumbnail screen.

Notes

- The value of the serial number is incremented by 1 every time a title is generated. When the value reaches 99999, the next number restarts from 00001.
- Duplicate clip titles can be generated if you reset the serial number after recording several clips or the same is true depending on the value setting. Care should be taken when setting the serial number.
- The “PREFIX” setting is saved in memory banks, but the “NUMERIC” setting is not saved (see page 96).

6-1-4 Assigning User-Defined Clip and Clip List Names

The following standard format names are assigned automatically to clips and clip lists that are created or recorded by XDCAM devices.

Clips: C0001.MXF to C4999.MXF

Clip lists: E0001E01.SMI to E0099E01.SMI

This unit can handle clips and clip lists with user-defined names as well as names in the standard format.¹⁾

1) This is supported from firmware version 1.5.

Limitations

- Letters, numbers and symbols from the Unicode 2.0 character set can be used. However, the following control characters and symbols cannot be used.
 - Control characters: U+0000 to U+001F, U+007F
 - Symbols: ", *, /, :, <, >, ?, \, |
- Depending on the character type, the length of user-defined names (the “C*” or “E*E01” part) may be limited to 14 characters. (The limit for ASCII characters is 56 characters.)
- All file name extensions are converted automatically to uppercase.
- Titles are used as user-defined clip names on this unit. Therefore, the available characters are limited to those supported by the title function.
- Files generated along with clips and clip lists use the same names (the “C*” or “E*” part of the following file names).
 - Clips: Metadata files (C*M01.XML), proxy AV data files (C*S01.MXF)
 - Clip lists: Metadata files (E*M01.XML)
- The following names cannot be assigned.
 - Clips: C0000.MXF
 - Clip lists: E0000E01.SMI, E0100E01.SMI to E9999E01.SMI, E0000.SMI, E0100.SMI to E9999.SMI
- The following names should be avoided.
 - Clips: C5000.MXF to C9999.MXF
 - Clip lists: E0001.SMI to E0099.SMI

To assign clip names on this unit

The title assigned to clip becomes its clip name (file name).

Notes

- When the first letter of the title setting with basic menu item 035 “CLIP TITLE NAMING SELECT” is a space or period (.), the clip name is the title string minus the first letter.
- An FTP client that supports UTF-8 is required to use Unicode characters other than ASCII characters. Command prompt FTP commands do not support UTF-8.

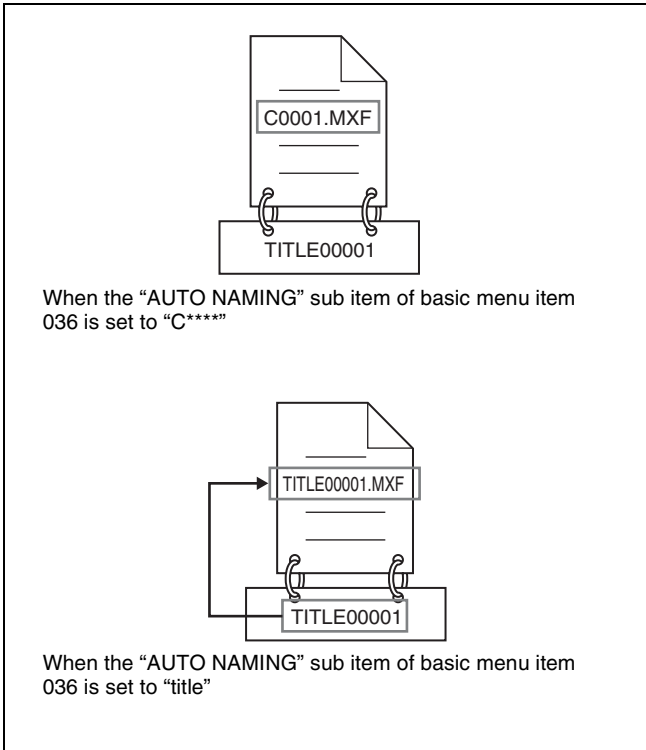

- 1 Before you start, set the "TITLE" sub item of basic menu item 035 "CLIP TITLE NAMING SELECT" to "enable," and set a title (*see the previous section*).
- 2 Press the MENU button.
- 3 Rotate the jog dial or the shuttle dial to display menu item 036.
- 4 With the STOP button held down, rotate the jog dial or the shuttle dial to move the "*" to the left of the item names to "NAMING FORM."

The "*" indicates the selected item.

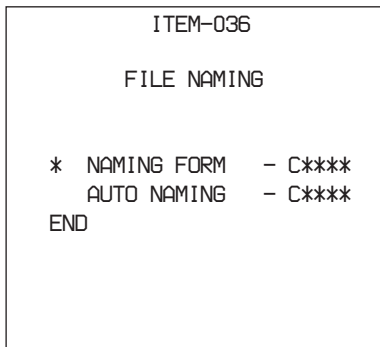

- 5 With the SHUTTLE button held down, rotate the jog dial or the shuttle dial to select "free."

You are now able to use clips and clip lists with user-defined names.

- 6 With the STOP button held down, rotate the jog dial or the shuttle dial to move the "*" to the left of "AUTO NAMING."
- 7 With the SHUTTLE button held down, rotate the jog dial or the shuttle dial to select "title."
- 8 Press the SET button.

The same name will now be given to newly recorded clips.

To use clips and clip lists with user-defined names over FAM and FTP connections

Carry out steps 2 to 5 of "To assign clip names on this unit," and then press the SET button.

It is now possible to write, transfer, and rename clips and clip lists with user-defined names over file access mode (FAM) connections (*see page 78*) and FTP connections (*see page 80*).

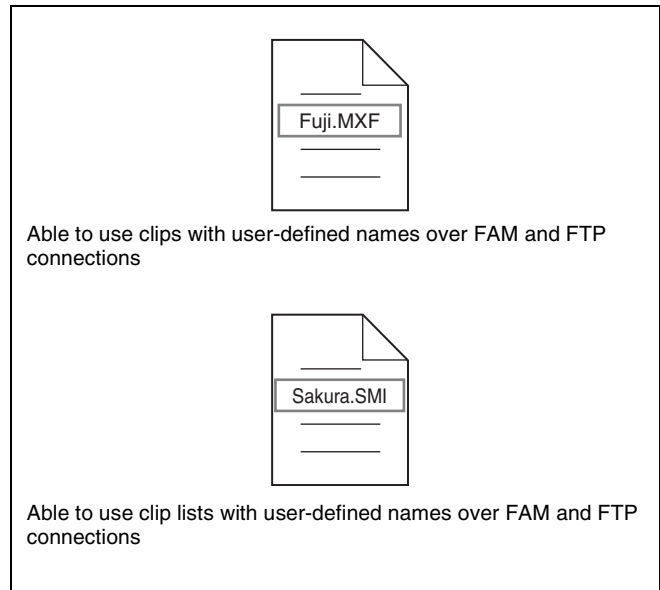

To check clip names

Press the THUMBNAIL button to display the thumbnail screen, and select the clip whose name you want to check. The name of the selected clip appears at the upper left of the screen.

See "Cuing up a desired clip" (page 52) for more information about the thumbnail screen.

Notes

- The item at the upper left of the screen is displayed according to the following order of priority.
Title > User-defined clip name > Standard format clip name
Therefore, the display of this item changes as following, depending on whether there is a title.
 - When a title has been set as a clip name on this unit, for clips recorded on this unit, the title is displayed.

- The user-defined name or standard format name is displayed for clips without a title.
- If the firmware of your XDCAM device is version 1.4x or lower, clips with user-defined names appear as “C5000” to “C9999,” in order of recording.

6-2 File Access Mode File Operations

File access mode operating environment

Operating system requirements for file operations by file access mode (called FAM below) are as follows.

- Computer operating system: Microsoft Windows 2000 Service Pack 4 or higher, or Microsoft Windows XP

Preparations

Do the following on the remote computer and this unit.

- Install the FAM driver on the remote computer (*see the next section*).
- Set extended menu item 215 “i.LINK MODE” to “FAM.”

See 7-3-2 “Extended Menu Operations” (page 108) for more information about how to make this setting.

To install the FAM driver

Insert the supplied CD-ROM (PDZ-1 Proxy Browsing Software) in the CD-ROM drive of the computer and execute the Setup.exe file, then follow the installation instructions.

For details, refer to the ReadMe file contained on the CD-ROM disc.

Note

Use Version 1.4 or higher of the FAM driver. The FAM driver on the supplied CD-ROM is Version 1.4 or higher. If a FAM driver is already installed on your computer, check the version.

To check the version, click “Add or Remove Programs” (Windows XP) or “Add/Remove Programs” (Windows 2000), select “ProDisc,” and then click “Click here for support information.”

6-2-1 Making FAM Connections

1 If there is a disc loaded in this unit, put the unit into the following state.

- Recording, playback, search and other disc operations (*see page 16*): Stopped
- THUMBNAIL button (*see page 13*): Off
- Disc access by DELETE, FORMAT, and so on in the System menu (*see page 117*): Stopped
- Unsaved current clip list: Save or clear
- Extended menu item 258 “LIVE LOGGING”: off

- 2 If this unit is connected to a remote computer by FTP, log out from the FTP session (*see page 80*).
- 3 Connect the i.S400 (i.LINK) connector on this unit to the i.LINK (IEEE1394) connector on the remote computer, using an i.LINK cable (*see connections illustration on page 27*).

Windows recognizes this unit as a removable disc, and displays one of the following icons on the remote computer's task bar:

- **Windows 2000:** 
- **Windows XP:** 

The remote computer is now able to perform file operations when a disc is inserted into this unit.

Note

You will not be able to log in if you put the unit into the state described in step 1 after connecting the cable. To log in, disconnect the cable, put the unit into the state described in step 1, and connect it again.

Operation limitations during FAM connections

- Control panel and LCD panel operations are disabled, except for operations with the EJECT and STATUS buttons.
- This unit cannot be controlled from devices connected to the REMOTE connector (D-sub 9-pin) and i.S400 (i.LINK) connector.
- Signal input to this unit and signal output from this unit are stopped.

6-2-2 Operating on Files

- 1 Start Explorer.

Check that a drive letter has been assigned to this unit. (The drive letter will differ depending on the number of other peripherals connected to the remote computer.)

- 2 Use Explorer to perform file operations on the disc loaded in this unit.

You can operate in the same way that you operate on local drives and files on network computers.

Notes

- If you power this unit off during an FAM connection, the data transferred thus far is discarded.
- All file operations are not possible for some types of files.

For details, see 6-1-2 "File Operation Restrictions" (page 73).



To eject discs from a remote computer

Right click the icon representing this unit in Explorer, and select Eject from the menu which appears.

6-2-3 Exiting File Operations

Note

Do not disconnect the cable before performing steps 1 to 3.

- 1 Do one of the following on the  or  icon displayed in the remote computer's taskbar.
 - Double click.
 - Right click, and select one of the following commands from the menu which appears.
 - **Windows 2000:** Unplug or eject hardware
 - **Windows XP:** Safely Remove Hardware
 - **Windows 2000:** The Unplug or Eject Hardware dialog appears.
 - **Windows XP:** The Safely Remove Hardware dialog appears.
- 2 Select "Sony XDCAM PDW-R1 IEEE 1394 SBP2 Device" and click Stop.

The Stop a Hardware device dialog appears.
- 3 Select "Sony XDCAM PDW-R1 IEEE 1394 SBP2 Device" and click OK.
 - **Windows 2000:** A confirmation message appears.
 - **Windows XP:** "Sony XDCAM PDW-R1 IEEE 1394 SBP2 Device" is deleted from the Hardware devices list.

This unit can now resume normal operations. (The limitations described in "Operation limitations during FAM connections" (*see page 79*) no longer apply.)

- 4 Disconnect the i.LINK cable as required.

To reconnect

To reconnect after exiting file operations, do one of the following, depending on whether an i.LINK cable is connected.

i.LINK cable is not connected: Connect this unit and a remote computer with an i.LINK cable.

i.LINK cable is connected: Disconnect the i.LINK cable from either this unit or the remote computer, wait for at least 10 seconds, and then reconnect the disconnected cable.

The unit is powered off and an i.LINK cable is connected: Power the unit on.

To disable FAM connections

Execute one of the procedures described in the previous section “Reconnecting” to make a FAM connection between this unit and the remote computer. To disable FAM connections, set extended menu item 215 “i.LINK MODE” to “AV/C.”

For more information about how to make this setting, see 7-3-2 “Extended Menu Operations” (page 108).

6-3 FTP File Operations

File operations between this unit and a remote computer can be carried out by the File Transfer Protocol (called FTP below).

Preparations

- 1** Connect the network connectors of this unit and a remote computer with a network cable (*see connections illustration on page 26*). Or connect this unit to the network to which the remote computer is connected (*see connections illustration on page 26*).
- 2** Set the IP address and other network setting items for this unit.

For details, see “To change network settings” (page 115).

If network settings have already been made
Check the IP address of this unit.

For details, see “To check the assigned IP address” (page 115).

- 3** Set the remote control switch to “NETWORK” (*see page 12*).

6-3-1 Making FTP Connections

FTP connections between this unit and a remote computer can be made with either of the following.

- The command prompt
- FTP client software

This section explains how to use the command prompt. For more information about using FTP client software, refer to the documentation of the FTP client software on your system.

Note

An FTP client that supports UTF-8 is required to use Unicode characters other than ASCII characters. Command prompt FTP commands do not support UTF-8.

To log in

If this unit is connected to a remote computer with a FAM connection, first exit file operations on the FAM connection (*see page 79*).

- 1** Load a disc into this unit and put the unit into the following state.

- Recording, playback, search and other disc operations (*see page 16*): Stopped
- THUMBNAIL button (*see page 13*): Off
- Disc access by DELETE, FORMAT, and so on in the System menu (*see page 117*): Stopped
- Unsaved current clip list: Save or clear
- Extended menu item 258 “LIVE LOGGING”: off

Note

Login is not possible unless a disc is loaded and the unit is in the state described above.

- 2 Start the command prompt.
- 3 Enter “ftp <SP> <IP address>,” and press the Enter key. (<SP> refers to a space.)

For example, if the IP address of this unit is set to “192.168.001.010,” enter “ftp 192.168.1.10.”

Refer to the Windows help for more information about the FTP command.

If the connection succeeds, you are prompted to enter a user name.

- 4 Enter the user name “admin” and press the Enter key.
When the user name is verified, you are prompted to enter a password.
- 5 Enter the password and press the Enter key.

The password is set to “pdw-r1” when the unit is shipped from the factory.
The login is complete when the password is verified.

See 6-3-2 “Command List” (page 82) for the FTP protocol commands supported by this unit.

If the connection times out

This unit terminates FTP connections if no command is received within 90 seconds of the last command. If this occurs, log out (*see the next section*) and repeat steps **2** to **4**.

Note

If you power this unit off during an FTP connection, the data transferred thus far is discarded.

To log out

To log out after finishing file operations, enter “QUIT” at the command prompt and press the Enter key.

6-3-2 Command List

The FTP protocol commands supported by this unit include standard commands (*see the next section*) and extended commands (*see page 86*).

Notes

- To execute FTP commands, you must install application software such as PDZ-1 on your computer.
- The commands supported by application software vary.

Standard commands

The following table shows the standard FTP commands supported by this unit.

In the command syntax column, <SP> means a space, entered by pressing the space bar, and <CRLF> means a new line, entered by pressing the Enter key.

Command name	Description	Command syntax
USER	Send this command to begin the login process.	USER <SP> <username> <CRLF> Input example: USER admin
PASS	After sending the USER command, send this command to complete the login process.	PASS <SP> <password> <CRLF> Input example: PASS pdw-r1
QUIT	Terminates the FTP connection. If a file is being transferred, terminates after completion of the transfer.	QUIT <CRLF>
PORT	Specifies the IP address and port to which this unit should connect for the next file transfer (for data transfer from this unit).	PORT <SP> <h1,h2,h3,h4,p1,p2> <CRLF> <ul style="list-style-type: none"> • h1 (most significant byte) to h4 (least significant byte): IP address • p1 (most significant byte), p2 (least significant byte): Port address Input example: PORT 10,0,0,1,242,48 (IP address: 10.0.0.1, Port number: 62000)
PASV	This command requests this unit to "listen" on a data port (which is not its default data port). (It puts this unit into passive mode, waiting for the remote computer to make a data connection.)	PASV <CRLF>
TYPE	Specifies the type of data to be transferred.	TYPE <SP> <type-code (options delimited by <SP>)> <CRLF> <type-code> can be any of the following. However, for XDCAM, data is always transferred as "1," regardless of the type-code specification. <ul style="list-style-type: none"> • A: ASCII <ul style="list-style-type: none"> - N: Non-print - T: Telnet format - C: ASA Carriage Control • E: EBCDIC <ul style="list-style-type: none"> - N: Non-print - T: Telnet format - C: ASA Carriage Control • I: IMAGE (Binary) (default) • L: LOCAL BYTE <ul style="list-style-type: none"> - SIZE: byte size Input example: TYPE I

Command name	Description	Command syntax
STRU	Specifies the data structure.	<p>STRU <SP> <structure-code> <CRLF></p> <p><structure-code> can be any of the following. However, for XDCAM, the structure is always "F," regardless of the structure-code specification.</p> <ul style="list-style-type: none"> • F: File structure (default) • R: Record structure • P: Page structure <p>Input example: STRU F</p>
MODE	Specifies the transfer mode.	<p>MODE <SP> <mode-code> <CRLF></p> <p><mode-code> can be any of the following. However, for XDCAM, the mode is always "S," regardless of the mode-code specification.</p> <ul style="list-style-type: none"> • S: Stream mode (default) • B: Block mode • C: Compressed mode <p>Input example: MODE S</p>
LIST	Sends a list of files from this unit to the remote computer.	<p>LIST <SP> <options> <SP> <path-name> <CRLF></p> <p><options> can be any of the following.</p> <ul style="list-style-type: none"> • -a: Also display file names that begin with "." • -F: Append "/" to directory names. <p>The following data is transferred, depending on whether <path-name> specifies a directory or file.</p> <ul style="list-style-type: none"> • Directory specified: A list of the files in the specified directory • File specified: Information about the specified file • No specification: A list of the files in the current directory <p>The wildcard characters "*" (any string) and "?" (any character) may be used in <path-name>.</p> <p>Input example 1: LIST -a Clip Input example 2: LIST Clip/*.MXF</p>
NLST	Sends a list of file names from this unit to the remote computer, with no other information.	<p>NLST <SP> <options or path-name> <CRLF></p> <p>The following options may be specified when no path name is specified.</p> <ul style="list-style-type: none"> • -a: Also display file names that begin with "." • -l: Display information other than file name (gives the same result as the LIST command). • -F: Append "/" to directory names. <p>The following data is transferred, depending on whether <path-name> specifies a directory or file.</p> <ul style="list-style-type: none"> • Directory specified: A list of the file names only in the specified directory • No specification: A list of the file names only in the current directory. <p>The wildcard characters "*" (any string) and "?" (any character) may be used in <path-name>.</p> <p>Input example 1: NLST -l Input example 2: NLST Clip/*.MXF</p>
RETR	Begins transfer of a copy of a file in the specified path on this unit to the current directory on the remote computer.	<p>RETR <SP> <path-name> <CRLF></p> <p>Input example: RETR Clip/C0001.MXF</p>

Command name	Description	Command syntax
STOR	<p>Begins transfer of a copy of a file in the specified path on the remote computer to the current directory on this unit. Depending on the type of file transferred, the following files are created.</p> <ul style="list-style-type: none"> • C*.MXF file ^{a) c)} <ul style="list-style-type: none"> - C*M01.XML file (metadata) - C*S01.MXF file (proxy AV data) • E*E01.SMI file ^{b) c)} <ul style="list-style-type: none"> - E*M01.XML file (metadata) <p>a) *: 0001 to 4999 b) *: 0001 to 0099 c) With firmware version 1.5 and higher, the unit can handle files with user-defined names in the “C*” or “E*E01” part.</p> <p>Notes</p> <ul style="list-style-type: none"> • For C*.MXF files, the UMID of the copy source file is not saved. However, it is saved if an immediately preceding SITE UMMD extended command has been issued. • For C*.MXF files, some data, such as file header metadata, may be missing. • Depending on the transfer destination directory and the file type, transfer may not be possible. <p><i>For details, see 6-1-2 “File Operation Restrictions” (page 73).</i></p>	<p>STOR <SP> <path-name> <CRLF></p> <p>Input example: STOR Edit/E0001E01.SMI</p>
RNFR RNTO	<p>Rename a file. Specify the file to be renamed with the RNFR command, and specify the new name with the RNTO command. (Always follow a RNFR command with a RNTO command.)</p> <p><i>For details, see 6-1-2 “File Operation Restrictions” (page 73).</i></p>	<p>RNFR <SP> <path-name (before change)> <CRLF> RNTO <SP> <path-name (after change)> <CRLF></p> <p>Input example: RNFR General/info.txt RNTO General/clip_info.txt</p>
DELE	<p>Deletes the specified file on this unit.</p> <p>Note Depending on the directory and file type, deletion may not be possible.</p> <p><i>For details, see 6-1-2 “File Operation Restrictions” (page 73).</i></p>	<p>DELE <SP> <path-name> <CRLF></p> <p>Input example: DELE Clip/C0099.MXF</p>

Command name	Description	Command syntax
STAT	Sends information about properties of the specified file, or about data transfer status, from this unit to the remote computer. The following property information is sent, depending on the file type. <ul style="list-style-type: none"> • MXF file <ul style="list-style-type: none"> - File name - File type - CODEC type - Frame rate - Number of audio channels - Duration - UMID • non-MXF file <ul style="list-style-type: none"> - File name 	STAT <SP> <path-name> <CRLF> The following data is transferred, depending on whether a file is specified with <path-name>. <ul style="list-style-type: none"> • File specified: The properties of the specified file • No specification: The size of the data transferred thus far (unit: bytes) Input example: STAT Clip/C0001.MXF
ABOR	Requests this unit to abort a file transfer currently in progress.	ABOR <CRLF>
SYST	Displays the system name of this unit.	SYST <CRLF>
HELP	Displays a list of the commands supported by this unit, or an explanation of the specified command.	HELP <SP> <command-name> <CRLF> The following data is transferred, depending on whether a command name is specified with <command-name>. <ul style="list-style-type: none"> • Command name specified: Explanation of the specified command. • No specification: Command list Input example: HELP RETR
NOOP	Does nothing except return a response. (Used to check whether this unit is running.)	NOOP <CRLF>
PWD	Displays the current directory ("/" if the directory is the root directory).	PWD <CRLF>
CWD	Changes the current directory (moves from the current directory to another directory).	CWD <SP> <path-name> <CRLF> Moves to a directory as follows, depending on whether a directory is specified with <path-name>. <ul style="list-style-type: none"> • Directory specified: To the specified directory • No specification: To the root directory Input example: CWD General
CDUP	Moves one level up in the directory structure (makes the parent of the current directory be the current directory).	CDUP <CRLF>
MKD	Creates a new directory. Note Directories can be created only in the General directory. <i>For details, see 6-1-2 "File Operation Restrictions" (page 73).</i>	MKD <SP> <path-name> <CRLF>
RMD	Deletes a directory. Note Directories can be deleted only in the General directory. <i>For details, see 6-1-2 "File Operation Restrictions" (page 73).</i>	RMD <SP> <path-name> <CRLF>

Extended commands

The following table shows the extended FTP commands supported by this unit.

In the Command syntax column, <SP> means a space, entered by pressing the space bar, and <CRLF> means a new line, entered by pressing the Enter key.

Command name	Description	Command syntax
SITE REPF	<p>Sends an MXF file from the specified path on this unit to the remote computer. This command allows you to specify a segment in the body of the MXF file (composed of video and audio data), for transfer of the required segment only.</p> <p>Notes</p> <ul style="list-style-type: none"> • A segment greater than the file size cannot be specified. • This command cannot be used when the path names contains a space. Use the SITE REPFL command instead. 	<p>SITE REPF <SP> <path-name> <SP> <start-frame> <SP> <transfer-size> <CRLF></p> <p><start-frame> specifies an offset from the start of the file. Data is transferred from the video frame at the offset (the first frame is 0).</p> <p><transfer-size> specifies the number of video frames to transfer (specify 0 to transfer to the end of the file).</p> <p>Input example: SITE REPF Clip/C0001.MXF 5 150 (Transfer C0001.MXF. Body data is transferred only from frame 6 to frame 155.)</p>
SITE REPFL ^{a)}	<p>Sends an MXF file from the specified path on this unit to the remote computer. This command allows you to specify a segment in the body of the MXF file (composed of video and audio data), for transfer of the required segment only.</p> <p>Note</p> <p>A segment greater than the file size cannot be specified.</p>	<p>SITE REPFL <SP> "<path-name>" <SP> <start-frame> <SP> <transfer-size> <CRLF></p> <p><path-name> specifies the path name of the file to transfer. Enclose the path name in double quotation marks.</p> <p><start-frame> specifies an offset from the start of the file. Data is transferred from the video frame at the offset (the first frame is 0).</p> <p><transfer-size> specifies the number of video frames to transfer (specify 0 to transfer to the end of the file).</p> <p>Input example: SITE REPFL "Clip/sakura 0001.MXF" 5 150 (Transfer sakura 0001.MXF. Body data is transferred only from frame 6 to frame 155.)</p>
SITE FSTS	<p>Acquires the system status of this unit. One of the following status codes is sent.</p> <p>0: Initial state, or no disc is loaded. 1: File system mount is OK. 3: File system mount is not OK.</p>	SITE FSTS <CRLF>
SITE MEID	Acquires the media ID of the disc loaded in this unit.	SITE MEID <CRLF>
SITE FUNC	<p>Acquires the function and version of the extended commands. Information is sent in the following format.</p> <p><main function> <SP> <branch function> <SP> <branch function version></p> <p>For XDCAM, sent in a format like "200 MXF DISK 1" ("200" is a response code).</p>	SITE FUNC <CRLF>
SITE UMMD	When C*.MXF file is sent with the STOR command, the copy source UMID is saved if this command is invoked immediately before the STOR command.	SITE UMMD <CRLF>
SITE DF ^{a)}	Acquires the amount of free disc space.	SITE DF <CRLF>

Command name	Description	Command syntax
SITE CHMOD ^{a)}	Locks and unlocks clips. Also sets permissions for directories and files in the General directory.	<p>SITE CHMOD <SP> <flag> <SP> <path-name> <CRLF></p> <p>Specify one of the following values in <flag>, according to the specification in <path-name>.</p> <ul style="list-style-type: none"> • When a clip is specified in <path-name> <ul style="list-style-type: none"> 444: Lock. 666: Unlock. • When a directory in the General directory is specified in <path-name> <ul style="list-style-type: none"> 555: Forbid writing to the directory. 777: Allow writing to the directory. • When a file in the General directory is specified in <path-name> <ul style="list-style-type: none"> 444: Forbid writing to and execution of the file. 555: Forbid writing to the file, but allow execution. 666: Allow writing to the file, but forbid execution. 777: Allow writing to and execution of the file. <p>Input example: SITE CHMOD 444 Clip/C0001.MXF (Lock clip C0001.MXF)</p>

a) This is supported from firmware version 1.5.

6-4 Recording Continuous Time Code With FAM and FTP Connections

When you are connected to the unit by FAM or FTP, you can create new clips with time code that is continuous with the time code of the last frame of the last clip on the disc. To record continuous time code, first set the INT/EXT/RP188 switch to INT, set the PRESET/REGEN switch to REGEN, and set extended menu item 629 “TC SELECT” to “tc.” Then proceed as follows.

Note

Continuous time code cannot be recorded if extended menu item 629 “TC SELECT” is set to “vitec.”

See 7-3-2 “Extended Menu Operations” (page 108) for more information about how to make extended menu settings.

FAM connection

Write clip files to the unit from the computer or other device that is connected to this unit.

FTP connection

Use the “STOR” command to transfer clip files from the computer that is connected to this unit.

If you issue the “SITE UMMD” command immediately before the “STOR” command, the original time code of the transferred file is recorded, regardless of the settings of the INT/EXT/RP188 switch and the PRESET/REGEN switch.

7-1 Menu System Configuration

The settings for this unit use the following menus.

- **Setup menu**
See the next item.
- **Maintenance menu**
This provides audio control, and network and setup menu settings, and also shows version information.
For details, see 7-4 “Maintenance Menu” (page 112).
- **System menu**
This provides disc formatting, date setting, and similar operations.
For details, see 7-5 “System Menu” (page 117).

Setup menu

The setup menu system of this unit comprises the basic setup menu (also referred to simply as “basic menu”) and extended setup menu (also referred to simply as “extended menu”).

- **Basic menu**
This menu is used to make settings relating, for example, to the following.
 - the digital hours meter
 - the preroll time
 - the text information superimposed on the video output to the monitor
 - the menu banks for retaining menu settings
- **Extended menu**
This menu is used to make a wide range of settings relating to the functions of this unit, for example, the control panel functions, video and audio control, and digital data processing.

Configuration of the basic setup menu

The basic setup menu comprises the following groups of items.

Item group	Function	Refer to
Items H01 to H15	Display of the total number of hours the unit has been powered on, and other information collected by the digital hours meter	<i>page 120</i>
Items 001 to 099	Settings relating to the preroll time, superimposed text information, switching between 525(U) line, 525(J) line and 625 line operation modes, etc.	<i>page 90</i>
Items B01 to B20	Settings relating to the menu banks for saving menu settings	<i>page 93</i>

Configuration of the extended setup menu

The extended setup menu comprises the following groups of items.

Item group	Function	Refer to
Items 100 to 199	Settings relating to control panels	<i>page 97</i>
Items 200 to 299	Settings relating to the remote control interface	<i>page 98</i>
Items 300 to 399	Settings relating to editing operations	<i>page 99</i>
Items 400 to 499	Settings relating to preroll	<i>page 100</i>
Items 500 to 599	Settings relating to disc protection	<i>page 101</i>
Items 600 to 699	Settings relating to the time code, metadata, and UMID	<i>page 101</i>
Items 700 to 799	Settings relating to video control	<i>page 103</i>
Items 800 to 899	Settings relating to audio control	<i>page 106</i>
Items 900 to 999	Settings relating to digital processing	<i>page 108</i>

7-2 Basic Setup Menu

7-2-1 Items in the Basic Setup Menu

The basic menu items (excluding the items related to the digital hours meter) are listed in the following table.

- Item names are the names which appear in the video panel and on an external monitor, when the input signals to the monitor are the video signals output from the VIDEO OUT 2 (SUPER)/SDI OUT (SUPER) connector.

An abbreviated name appears in the time data display section when you press the NEXT button.

- The values in the Settings column are the values which appear in the time data display section. (The values may appear in a different format in the video panel and on an external monitor. In this case, the video panel values are shown in parentheses.) Underlined values are the factory defaults.

Item number	Item name	Settings
001	PREROLL TIME	0 s (0 sec)... <u>5 s (5 sec)</u>... 30 s (30 sec) : Set the preroll time to between 0 and 30 seconds in steps of 1 second. A preroll time of at least 5 seconds is recommended when using this unit for editing.
002	CHARACTER H-POSITION	Adjust the horizontal screen position (as a hexadecimal value) of the text information displayed on the monitor. ^{a)} 00... <u>0A</u> ...2A (525(U)/525(J) line modes) /00... <u>09</u> ...29 (625 line mode) : The hexadecimal value 00 is for the far left of the screen. Increasing the value moves the position of the characters to the right. a) Video panel and external monitor (when the input signals to the monitor are the video signals output from the VIDEO OUT 2 (SUPER)/SDI OUT (SUPER) connector) Set this item by adjusting to the required position while viewing the monitor.
003	CHARACTER V-POSITION	Adjust the vertical screen position (as a hexadecimal value) of the text information displayed on the monitor. ^{a)} 00... <u>2E</u> ...38 (525(U)/525(J) line modes)/00... <u>37</u> ...43 (625 line mode) : The hexadecimal value 00 is for the top of the screen. Increasing the value lowers the position of the characters. a) Video panel and external monitor (when the input signals to the monitor are the video signals output from the VIDEO OUT 2 (SUPER)/SDI OUT (SUPER) connector) Set this item by adjusting to the required position while viewing the monitor.
005	DISPLAY INFORMATION SELECT	Determine the kind of text information to be displayed on the monitor. ^{a)} off (display off) : Do not output text information. <u>T&sta</u> (time data & status) : Time data and the units status. <u>T&UB</u> (time data & UB) : Time data and user bit data. (When UB (user bit data) is selected with the COUNTER SEL button, the user bit data and time data arranged in that order are displayed.) <u>T&CNT</u> (time data & CNT) : Time data and counter count. (When COUNTER is selected with the COUNTER SEL button, the counter count and time data arranged in that order are displayed.) <u>T&T</u> (time data & time data) : Time data and time code (TC or VITC). <u>T&clp</u> (time data & clip name) : Time code and clip name <u>time</u> (time data only) : Time data only. a) Video panel and external monitor (when the input signals to the monitor are the video signals output from the VIDEO OUT 2 (SUPER)/SDI OUT (SUPER) connector)

Item number	Item name	Settings
006	LOCAL FUNCTION ENABLE	Determine which recording and playback control buttons on the control panel are enabled when this unit is controlled from external equipment. dis (all disable) : All buttons and switches are disabled. st&ej (stop & eject) : Only the STOP button and EJECT button are enabled. ena (all enable) : All buttons and switches are enabled.
007	TAPE TIMER DISPLAY	Determine whether to display the counter in 12-hour mode or 24-hour mode. + -12H (+ /-12H) : 12-hour mode 24H : 24-hour mode
009	CHARACTER TYPE	Determine the type of characters such as time code displayed on the monitor. ^{a)} white : White letters on a black background. black : Black letters on a white background. W/out : White letters with black outline. B/out : Black letters with white outline. a) Video panel and external monitor (when the input signals to the monitor are the video signals output from the VIDEO OUT 2 (SUPER)/SDI OUT (SUPER) connector) Set this item by selecting the required type while viewing the monitor.
011	CHARACTER V-SIZE	Determine the vertical size of characters such as time code displayed on the monitor. ^{a)} ×1 : Standard size ×2 : 2 times standard size a) Video panel and external monitor (when the input signals to the monitor are the video signals output from the VIDEO OUT 2 (SUPER)/SDI OUT (SUPER) connector) Set this item by selecting the required size while viewing the monitor.
012	CONDITION DISPLAY ON VIDEO MONITOR	Select whether to display disc condition marks on the monitor. ^{a)} dis (disable) : Do not display. ena (enable) : Display. a) Video panel and external monitor (when the input signals to the monitor are the video signals output from the VIDEO OUT 2 (SUPER)/SDI OUT (SUPER) connector)
013	525/625 SYSTEM SELECT	Specify whether to enable switching between 525(U) line, 525(J) line and 625 line modes. off : Do not enable system switching. on : Enable system switching. <i>For the switching between 525(U)/525(J)/625 line modes, see page 95.</i> Note When you switch line modes, all basic menu and extended menu items are set to the factory defaults for the selected line mode.
015	LCD CHARACTER TYPE	Specify the type of characters used to display information on the monitor ^{a)} when the STATUS button is pressed. W/out : White letters with black outline. white : White letters on a black background. a) Video panel and external monitor (when the input signals to the monitor are the video signals output from the VIDEO OUT 2 (SUPER)/SDI OUT (SUPER) connector) Set this item by selecting the required type while viewing the monitor.



Item number	Item name	Settings
016	ALARM DISPLAY	<p>Select whether or not to display alarm messages.</p> <p>off: Do not display alarm messages. (However, certain important alarms are displayed).</p> <p>limit (on (limited)): Display only a minimum number of alarm messages.</p> <p>on: Display all alarm messages.</p> <p><i>For details about alarm message display conditions, see 8-4-1 “Alarm List” (page 122).</i></p>
017	SUB STATUS DISPLAY SELECT	<p>Determine the kind of sub status information to be displayed on the monitor. ^{a)}</p> <p>off: Do not output sub status information.</p> <p>rmain (disc remain): Available disc space (unit: minute)</p> <p>clip (clip no): Order of playback of the selected clip/total number of clips</p> <p>posi (playback position): Playback position within clip</p> <p>pbr (playback remain): The remaining playback time of the selected clip from the current playback position (hours:minutes:seconds:frames).</p> <p>a) Video panel and external monitor (when the input signals to the monitor are the video signals output from the VIDEO OUT 2 (SUPER)/SDI OUT (SUPER) connector)</p> <p>Note</p> <p>When menu item 005 is set to “off,” sub status information is not displayed when this item is set to anything other than “off.”</p>
024	MENU CHARACTER TYPE	<p>Determine the type of characters in menu text displayed on the monitor. ^{a)}</p> <p>white: White letters on a black background.</p> <p>black: Black letters on a white background.</p> <p>W/out: White letters with black outline.</p> <p>B/out: Black letters with white outline.</p> <p>a) Video panel and external monitor (when the input signals to the monitor are the video signals output from the VIDEO OUT 2 (SUPER)/SDI OUT (SUPER) connector)</p> <p>Set this item by selecting the required type while viewing the monitor.</p>
029	STORED OWNERSHIP	<p>Specify whether to enable changing UMID ownership information settings (COUNTRY, ORGANIZATION and USER).</p> <p>off: Do not enable.</p> <p>on: Enable.</p> <p><i>See 7-3-3 “Using UMID Data” (page 109) for more information about UMID.</i></p>
031	RECORDING FORMAT	<p>Select the recording format.</p> <p>IMX50 (IMX 50Mbps): MPEG IMX 50 Mbps</p> <p>IMX40 (IMX 40Mbps): MPEG IMX 40 Mbps</p> <p>IMX30 (IMX 30Mbps): MPEG IMX 30 Mbps</p> <p>DVCAM: DVCAM</p>
032	LCD MONITOR MODE	<p>Set the aspect ratio for the video panel.</p> <p>auto: the aspect ratio of the display screen automatically adjusts to the aspect ratio of the input material.</p> <p>16:9: set the aspect ratio to 16:9.</p> <p>4:3: set the aspect ratio to 4:3.</p>
034	MENU STATUS DISPLAY ON VIDEO MONITOR	<p>Specify whether to display the setup menu status at the left edge of the status display line when basic menu item 005 “DISPLAY INFORMATION SELECT” is set to “T&sta.”</p> <p>dis (disable): Do not display.</p> <p>ena (enable): Display. (The display is visible only when no disc is loaded, and during insertion and ejection of a disc.)</p>

Item number	Item name	Settings	
035	CLIP TITLE NAMING SELECT	Specify whether or not to allow user definition of the titles assigned to clips. off: Do not allow assignment. on: Allow assignment. <i>See 6-1-3 “Assigning User-Defined Clip Titles” (page 75) for more information about assigning titles.</i>	
	Sub-item		
	1	TITLE	Specify whether to assign titles to recorded clips. disable: Do not assign titles to clips. enable: Assign titles to clips.
	2	PREFIX	Set the prefix of the title (up to 10 characters). The allowable characters are alphanumeric characters, symbols (! # \$ % & ' () + , - . ; = @ [] ^ _ { } ~), and the space character. TITLE
3	NUMERIC	Set the initial value of the numeric part of the title (00001 to 99999, five-digit number). 00001	
036	FILE NAMING ^{a)}	Specify whether to allow use of clip and clip list files with user-defined names. <i>See 6-1-4 “Assigning User-Defined Clip and Clip List Names” (page 76) for details about how to make the settings.</i>	
	Sub-item		
	1	NAMING FORM	Specify the clip and clip list naming format. (Specify whether to allow use of files with user-defined names.) C****: Standard format (Do not allow use of files with user-defined names) free: Free format (Allow use of files with user-defined names)
2	AUTO NAMING	When “free” is selected under the sub-item “NAMING FORM,” specify whether to use the standard format name or the same name as the title for clips recorded on this unit. C****: Use the standard format for clip names. title: Use the title set in basic menu item 035 “CLIP TITLE NAMING SELECT” for clip names.	
B01	RECALL SETUP BANK-1	Set to “on” to recall menu settings from menu bank 1.	
B02	RECALL SETUP BANK-2	Set to “on” to recall menu settings from menu bank 2.	
B03	RECALL SETUP BANK-3	Set to “on” to recall menu settings from menu bank 3.	
B11	SAVE SETUP BANK-1	Set to “on” to save current menu settings to menu bank 1.	
B12	SAVE SETUP BANK-2	Set to “on” to save current menu settings to menu bank 2.	
B13	SAVE SETUP BANK-3	Set to “on” to save current menu settings to menu bank 3.	
B20	RESET SETUP MENU	Set to “on” to return the settings of the current menu to the factory default settings. Set to “bank-4” to set the current menu to the settings saved in menu bank 4. off on (on (default)): Return the current menu to the factory default settings. bank-4: Set the current menu to the settings saved in menu bank 4.	

a) This is supported from firmware version 1.5.

7-2-2 Basic Menu Operations

Basic setup menu operations

This section explains how to select setup menu items and how to change their values. The operations are common to both the basic menu and the extended menu.

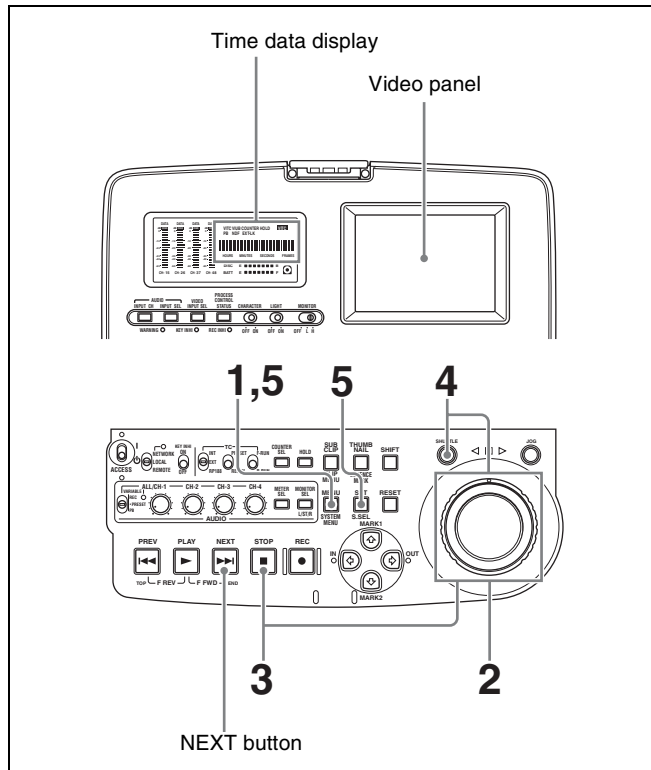

1 Press the MENU button.

The setup menu appears in the video panel, and on an external monitor to which the output of the VIDEO OUT 2 (SUPER)/SDI OUT (SUPER) connector is input. A cursor indicates the currently selected menu item.

The item number and current setting (elapsed time in the case of the digital clock) of the currently selected menu item also appear in the time data display section. The item number flashes to indicate that you can switch to another item.

Display in video panel and on external monitor

Cursor indicating the currently selected item

Group name for the currently selected item

```
HOUR METER
*H01 : OPE HOURS - 109
H11 : OPE HOURS r- 109
```

Display in time data display

```
H01: 000109
```

Item number (flashing)

Setting

To display the item name in the time data display

Hold down the NEXT button.

2 Rotate the jog dial or shuttle dial to select a menu item.

Rotate in the clockwise direction to select higher numbers, and in the counterclockwise direction to select lower number. The cursor moves in the direction of the rotation (the screen scrolls when the cursor reaches the top or bottom of the screen). The speed at which the cursor moves and speed with which menu items change vary with the rotation speed of the jog dial or the rotation angle of the shuttle dial. The STOP button lights when you select an item that contains sub items.

3 When the selected item contains sub items, you can select a sub item by holding down the STOP button and rotating the jog dial or shuttle dial.

The displays in the video panel, on an external monitor, and in the time data display section change as shown below when you hold down the STOP button. In the time data display section, the currently selected sub item number flashes to indicate that you can switch to another sub item.

Display in video panel and on external monitor

Cursor indicating the currently selected sub-item

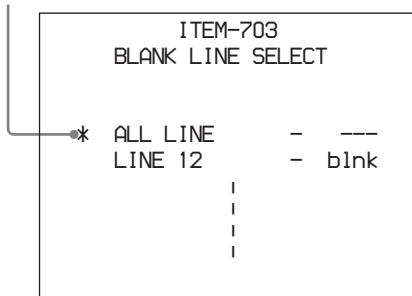

Display in time data display



Sub-item number (flashing while changing)

- 4 With the SHUTTLE button held down, rotate the jog dial or shuttle dial to change the setting.

The displays in the video panel, on an external monitor, and in the time data display section change as shown below when you hold down the SHUTTLE button. In the time data display section, the currently selected setting value flashes to indicate that you can change it to another value.

Display in video panel and on external monitor

Setting value

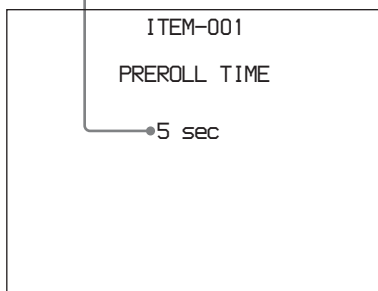

Display in time data display

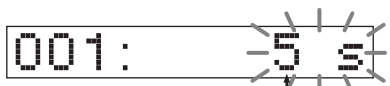

Setting value (flashing while changing)

- 5 Press the SET button.

This saves the new setting value, and the menu display disappears from the video panel, the external monitor, and the time data display section.

To abandon making a change

Press the MENU button before pressing the SET button.

The menu display disappears from the video panel, the external monitor, and the time data display section without the new setting value being saved.

Resetting the menu settings to their factory default values

To reset the current active menu settings to their factory default values, proceed as follows.

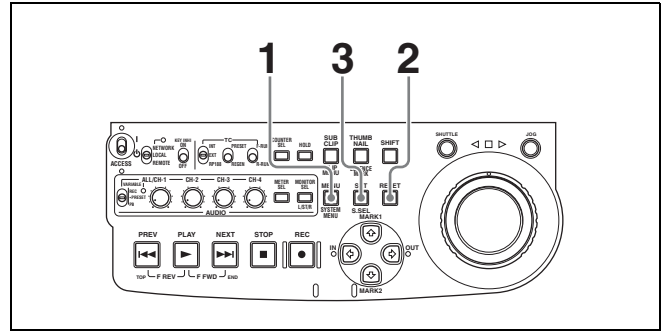

- 1 Press the MENU button.

The menu appears in the video panel, on an external monitor to which the output of the VIDEO OUT 2 (SUPER)/SDI OUT (SUPER) connector is input, and in the time data display section.

- 2 Press the RESET button.

The message “INITIALIZE ALL ITEMS TO FACTORY PRESET VALUES?” appears in the video panel and on the external monitor.

The message “Init setup?” appears in the time data display.

To abandon operations and return to the setup menu display

Press the RESET button again.

- 3 Press the SET button.

The menu settings are reset to their factory default settings.

Switching between 525(U) line, 525(J) line and 625 line modes (menu item 013)

To switch between 525(U) line, 525(J) line and 625 line operation modes, proceed as follows.

- 1 Press the MENU button.

- 2 Turn the jog dial or shuttle dial to display menu item 013 in the time data display.

- 3 Hold down the SHUTTLE button, and turn the jog dial or shuttle dial to set menu item 013 to “on.”
- 4 Press the SET button.
- 5 Hold down the SHUTTLE button, and turn the jog dial or shuttle dial to select the line mode 525(U), 525(J) or 625.
- 6 Press the SET button.
- 7 Turn the unit off (press the on/standby switch to put the unit in the standby state).

Next time the unit is turned on (when the unit is put in the operating state by pressing the on/standby switch), it operates in the new mode.

Menu bank operations (menu items B01 to B13)

This unit allows menu settings to be saved in what are termed “menu banks.” Saved sets of menu settings can be recalled for use as required.

To jump to menu item B01

You can recall any required menu by turning the jog dial or shuttle dial after pressing the MENU button.

If you press the MENU button first, then the COUNTER SEL button, you can jump directly to menu item B01 or H01. The recalled menu item toggles between B01 and H01 every time you press the COUNTER SEL button.

Saving the current active menu settings

Set one of basic menu items B11 “SAVE SETUP BANK-1” to B13 “SAVE SETUP BANK-3” to “on,” depending on which of the menu banks you wish to save in, then press the SET button.

Recalling settings from a menu bank

Set one of basic menu items B01 “RECALL SETUP BANK-1” to B03 “RECALL SETUP BANK-3” to “on,” depending on which of the menu banks you wish to recall from, then press the SET button.

To recall menu bank 4, select “bank-4” under menu item B20 “RESET SETUP MENU.”

Refer to the maintenance manual for more information about menu bank 4.

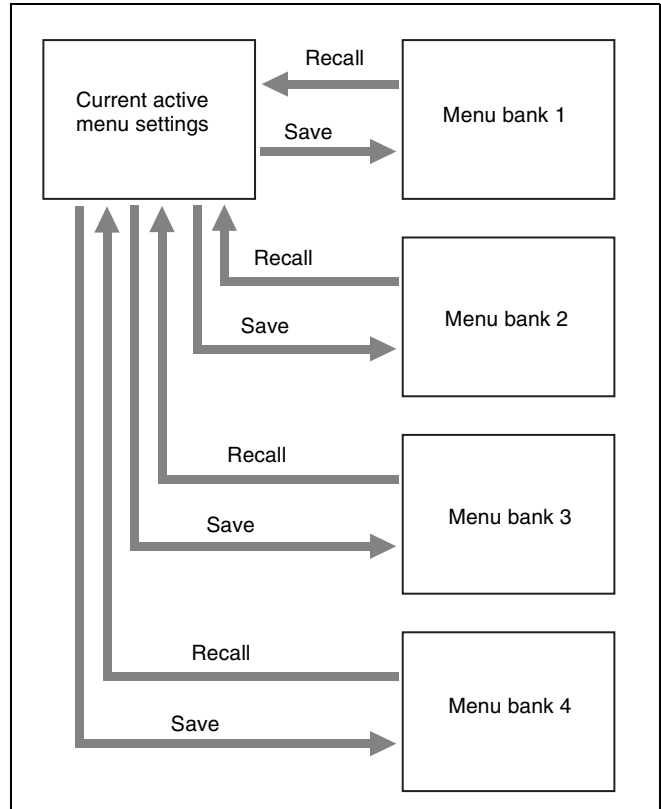

Note

The following message appears if the line mode of the menu bank that you are about to recall differs from the current line mode.

Display in the video panel and on an external monitor

```

ITEM-B01

RECALL SETUP BANK-1

System will be changed.
Are you sure you want
to execute?

EXECUTE : SET KEY
ABORT   : MENU KEY
  
```

Message in time data display

```

Execute?
  
```

Press the SET button to recall the settings and switch to the line mode saved in the menu bank. When you power the unit off and then on again, it will use the line mode and settings of the selected bank.

To cancel the recall, press the MENU button.

7-3 Extended Menu

7-3-1 Items in the Extended Menu

The following tables show the items in the extended menu.

- Item names are the names which appear in the video panel, and on an external monitor to which the output of the VIDEO OUT 2 (SUPER)/SDI OUT (SUPER) connector is input.
An abbreviated name appears in the time data display section when you press the NEXT button.

- The values in the Settings columns are the values which appear in the time data display section. (The values may appear in a different format in the video panel and on an external monitor. In this case, the video panel values are shown in parentheses.) Underlined values are the factory defaults.



Menu items in the 100s, relating to the control panels

Item number	Item name	Settings
101	SELECTION FOR SEARCH DIAL ENABLE	Select how the unit enters the shuttle or jog mode. dial (dial direct) : Press the SHUTTLE or JOG button or, except during recording/editing, turn the jog dial or shuttle dial. key (via search key) : Press the SHUTTLE or JOG button.
105	REFERENCE SYSTEM ALARM	Select whether or not to display a warning when the reference video signal is not supplied or is out of phase with the input video signal. off : No warning. on : Flash the STOP button as a warning.
107	REC INHIBIT LAMP FLASHING	Select whether or not to flash the REC INHI indicator when recording is prevented (see "REC INHI (recording inhibited) indicator" on page 18). off : Light the REC INHI indicator. on : Flash the REC INHI indicator.
108	AUTO EE SELECT	When a disc is inserted, select the operation modes in which input video and audio signals are automatically handled in E-E mode. S/F/R (stop/f.fwd/f.rev) : In stop/fast-forward/fast-reverse modes stop : In stop mode off : Do not put the unit into E-E mode automatically.
109	FORCED EE WHEN DISC UNLOAD	When "off" is selected in menu item 108, during disc loading/unloading and when no disc is inserted, select whether or not to control the output signal PB/EE setting. on : Do not control (the signal is always an E-E signal). off : Control.
114	AUDIO MONITOR OUTPUT LEVEL	When "moni" is selected in menu item 820, select whether or not to control the level of the audio signal output from the AUDIO OUT 1/3, 2/4 connectors with the volume control knob for the PHONES jack. var (variable) : Control. fixed : Do not control.
118	KEY INHIBIT	When the KEY INHI switch is set to ON, select which buttons can be operated. The following sub-items control different sets of buttons independently.
	Sub-item	
	1	MON./INPUT SEL
2	CONTROL PANEL	Select whether all switches and buttons other than the buttons specified with sub-item 1 and the MENU button are enabled. dis : Disabled. ena : Enabled.
121	FRAME PB MODE	Specify the frame mode for variable speed playback. field : Field playback frame : Frame playback. Compared to field playback, frame playback gives still pictures with higher precision.

Menu items in the 100s, relating to the control panels

Item number	Item name	Settings
131	AUDIO VOLUME	Select whether each of the ALL/CH-1, CH-2 to CH-4 adjustment knobs on the control panel is effective to control the audio recording level and playback level on each channel or the ALL/CH-1 adjustment knob alone functions as a master control to control the audio level on all channels together. each: Each of the ALL/CH-1, CH-2 to CH-4 adjustment knobs is effective to control each channel. all: The ALL/CH-1 adjustment knob alone functions as a master control. When “all” is selected, the ALL indicator to the right of the ALL/CH-1 adjustment knob lights up.
142	REPEAT MODE	Put the unit into repeat playback mode, or exit from repeat playback mode. off: Exits from repeat playback mode. play: Puts the unit into repeat playback mode.
143	INDEX PICTURE POSITION	Select the frame of the clip to use as the thumbnail image (index picture) when recording. 0sec to 10sec: Can be set in the range from 0 seconds (first frame of the clip) to 10 seconds, in units of 1 second.
145	MODE KEY ENABLE DURING RECORDING	Specify whether only the STOP button stops recording. ena (all enable): Recording stops when the EJECT button is pressed ^{a)} and when the PLAY, STOP, SHUTTLE, and JOG buttons are pressed. ^{b)} stop: Recording stops only when the STOP button is pressed. a) The disc is ejected after recording stops. b) The unit enters stop mode when the PLAY button is pressed, and enters still image mode (jog/shuttle mode) when the SHUTTLE or JOG button is pressed.
146	POWER SAVE MODE	Specifies whether to put the unit into power save mode. off: Do not put the unit into power save mode. on: Put the unit into power save mode. The following operations take slightly longer to start in power save mode. <ul style="list-style-type: none"> Recording, playback, jog and shuttle mode playback, search Display of the thumbnail screen and essence marks

Menu items in the 200s, relating to the remote control interface

Item number	Item name	Settings
214	REMOTE INTERFACE	When the remote control switch is set to REMOTE, select the device from which to remote-control this unit. 9PIN: Device connected to the REMOTE connector. i.LNK (i.LINK): Device connected to the  S400 (i.LINK) connector.
215	i.LINK MODE	Select the connection method for the  S400 (i.LINK) connector. AV/C: Connect with AV/C. FAM (FAM (PC REMOTE)): Connect with FAM.
216	PARALLEL RECORDING MODE	Specifies whether recording of video and audio on this unit should start and stop at the same time as recording on a camcorder connected to this unit by i.LINK(AV/C). off: Do not conduct parallel recording. on: Conduct parallel recording.
257	NETWORK ENABLE	Select the remote control switch positions which enable network connections. net (network): Only when the switch is set to “NETWORK.” n&9P (network & remote(9PIN)): When the switch is set to “NETWORK,” and when the switch is set to “REMOTE” and extended menu item 214 is set to “9PIN.” ^{a)} a) FTP connections can be made only when the device connected to the REMOTE connector (D-sub 9 pin) is in stop mode. During FTP connections, the device connected to the REMOTE connector cannot be used to control this unit.

Menu items in the 200s, relating to the remote control interface

Item number	Item name	Settings
258	LIVE LOGGING	<p>Enable or disable the live logging function when using the PDZ-1 Proxy Browsing Software.</p> <p>off: Disable. on: Enable.</p> <p>Note During live logging, regardless of the settings of the switches (INT/EXT/ RP188, PRESET/REGEN, and F-RUN/R-RUN) in the time data settings section, the internal time code generator always runs in free run mode. Time code cannot be recorded in internal preset mode.</p>

Menu items in the 300s, relating to editing operations

Item number	Item name	Settings
308	SELECTION OF STD/NON-STD FOR COMPOSITE VIDEO IN	<p>Select the STD or NON-STD mode in accordance with a composite video or S-video input.</p> <p>STD (forced STD): The STD mode is always used (forced STD mode). N-STD (forced non-STD): Use this setting when the input video signal is unstable (forced NON-STD mode).</p> <p>Note When using a VCR with no built-in time base corrector (e.g. a home-use VHS-system VCR), select N-STD.</p>
310	REC INHIBIT	<p>Select whether recording is inhibited.</p> <p>off: Do not inhibit recording. on: Inhibit recording.</p>
320	DIGITAL AUDIO PB PROCESS ON EDIT POINT	<p>Select the treatment of audio playback at edit points.</p> <p>cut: Carry out a cut (possibly resulting in audio discontinuities at the edit point). fade: Fade out and fade in.</p>
335	OUTPUT REFERENCE SEL	<p>Select the reference signal of this unit.</p> <p>ref (ref. video): Use the signal input to the REF VIDEO IN connector as the reference signal. auto: According to the operation mode, automatically select either the signal input to the REF VIDEO IN connector or the input video signal selected with the VIDEO INPUT SEL button as the reference signal.</p> <p><i>For more details, see the following item "External synchronization to reference signal generators" (page 100).</i></p> <p>The input digital audio signals and video signals must be synchronized with the reference signal input to the REF VIDEO IN connector.</p>

External synchronization to reference signal generators

The internal reference signal generator is synchronized either to a reference signal input to the REF VIDEO IN connector or an input video signal. Depending on the settings of extended menu items 335 and 308, and the input

signal selection, the external synchronization status is as shown in the following table.

The video signals are output always synchronized to the internal reference signal.

VIDEO INPUT SEL button setting		COMPOSITE			
Item 335 setting		ref		auto	
Item 308 setting		STD	N-STD	STD	N-STD
Operation mode		External synchronization status			
When a signal is input to the REF VIDEO IN connector	E-E mode	REF ^{a)}	REF ^{a)}	REF ^{a)}	REF ^{a)}
	Normal playback				
	REC button pressed				
	Recording			INPUT/Free ^{b)}	
When no signal is input to the REF VIDEO IN connector	E-E mode	INPUT/Free ^{b)}	Free RUN ^{d)}	INPUT/Free ^{b)}	Free RUN ^{d)}
	Normal playback				
	REC button pressed				
	Recording				

VIDEO INPUT SEL button setting		SDI		i.LINK	SG
Item 335 setting		ref		auto	ref/auto
Item 308 setting		STD/N-STD		STD/N-STD	STD/N-STD
Operation mode		External synchronization status			
When a signal is input to the REF VIDEO IN connector	E-E mode	REF ^{a)}	REF ^{a)}	REF ^{a)}	REF ^{a)}
	Normal playback				
	REC button pressed				
	Recording			SDI IN/Free ^{c)}	
When no signal is input to the REF VIDEO IN connector	E-E mode	SDI IN/Free ^{c)}	SDI IN/Free ^{c)}	Free RUN ^{d)}	Free RUN ^{d)}
	Normal playback				
	REC button pressed				
	Recording				

- a) Synchronize to the reference signal input to the REF VIDEO IN connector.
 b) Synchronize to the signal input to the VIDEO IN connector. If no signal is input to the connector, no synchronization is made.

- c) Synchronize to the signal input to the SDI IN connector. If no signal is input to the connector, no synchronization is made.
 d) No external synchronization is made.

Menu items in the 400s, relating to preroll

Item number	Item name	Settings
401	FUNCTION MODE AFTER CUE-UP	Select the state that the unit goes into after a cuing-up operation. stop : Stops (the stop mode). still : Still playback (in jog and shuttle mode).

Menu items in the 500s, relating to disc protection

Item number	Item name	Settings
501	STILL TIMER	To protect the disc against shock and vibrations, and to lengthen the life of the laser diodes, the unit automatically enters standby off mode whenever a specified time elapses in a disc stop mode (stop mode or the still picture mode of search mode). This allows you to set the time after which the unit exits a disc stop mode and enters standby off mode. 0.5 s (0.5 sec)... 8 m (8 min)... 30 m (30 min): Can be set in the range from 0.5 seconds to 30 minutes. off: Do not put into standby off mode.

Menu items in the 600s, relating to the time code, metadata, and UMID

Item number	Item name	Settings
601	VITC POSITION SEL-1	Select a line into which to insert VITC signals for IMX recording signals ^{a)} and DVCAM playback signals. ^{b)} 12 H (12 line)... 16 H (16 line)... 20 H (20 line) (in 525(U)/525(J) line modes) 9 H (9 line)... 19 H (19 line)... 22 H (22 line) (in 625 line mode) Note You can insert the VITC signal in two places. To insert it in two places, set both items 601 and 602. a) In the IMX format, VITC is inserted as video signals in vertical blanking sections. Because these signals are output as video signals during playback, the insertion line can be specified only for recording. b) In the DVCAM format, VITC is recorded as VAUX (Video Auxiliary) data. Because VITC is inserted into video signals by the VITC generator only during playback, the insertion line can be specified only for playback.
602	VITC POSITION SEL-2	Select a line into which to insert VITC signals for IMX recording signals ^{a)} and DVCAM playback signals. ^{b)} 12 H (12 line)... 18 H (18 line)... 20 H (20 line) (in 525(U)/525(J) line modes) 9 H (9 line)... 21 H (21 line)... 22 H (22 line) (in 625 line mode) Note You can insert the VITC signal in two places. To insert it in two places, set both items 601 and 602. a) In the IMX format, VITC is inserted as video signals in vertical blanking sections. Because these signals are output as video signals during playback, the insertion line can be specified only for recording. b) In the DVCAM format, VITC is recorded as VAUX (Video Auxiliary) data. Because VITC is inserted into video signals by the VITC generator only during playback, the insertion line can be specified only for playback.
605	TCG REGEN MODE	Select the signal to be regenerated when the time code generator is in the regeneration mode (i.e., when the PRESET/REGEN switch is set to REGEN). TC&UB: Both the time code and user bits are regenerated. TC: Only the time code is regenerated. UB: Only the user bits are regenerated.
607	U-BIT BINARY GROUP FLAG	Select the user bits to be used in the time code generated by the time code generator. 000 (000: not specified): Character set not specified. 001 (001: iso character): 8-bit characters compliant with ISO 646 and ISO 2022. 010 (010: unassigned-1): Undefined. 011 (011: unassigned-2): Undefined. 100 (100: unassigned-3): Undefined. 101 (101: page / line): SMPTE 262M page/line multiplex system. 110 (110: unassigned-4): Undefined. 111 (111: unassigned-5): Undefined.

Menu items in the 600s, relating to the time code, metadata, and UMID

Item number	Item name	Settings
611	TC OUTPUT PHASE IN EE MODE	Select the time code output mode for output from the TC OUT connector in E-E mode. mutng (muting) : Suppress the output. thru (through) : Output the time code input to the TC IN connector as it is. v-in (video input phase) : Output the time code with the same phase as the input video signal phase. v-out (video output phase) : Output the time code with the same phase as the output video signal phase.
612	TC OUTPUT MUTING IN SEARCH MODE	Select whether to suppress the output from the TC OUT connector in jog/shuttle mode. on : Suppress. off : Do not suppress.
619	VITC	Specify whether or not to record the VITC generated by the internal time code generator. off : Do not record internally generated VITC. on : Record internally generated VITC. Note Even if this item is set to “off,” VITC is recorded if the input video signal contains VITC and the VITC line is set to “thru” with item 723.
628	DF MODE	In 525(U)/525(J) line modes, when the INT/EXT/RP188 switch is set to INT and the PRESET/REGEN switch is set to PRESET, select the frame mode of the internal time code generator and counter. df (on (df)) : Drop-frame mode ndf (off (ndf)) : Non-drop frame mode
629	TC SELECT	Select the type of time data to show in the time data display, and the type of external time code when the INT/EXT/RP188 switch is set to EXT and the PRESET/REGEN switch is set to REGEN. vitc : Display time code as VITC, or select VITC as the external time code. tc : Display time code as TC, or select TC as the external time code. <i>See 4-1-2 “Recording Time Code and User Bit Values” (page 44) for more information about selecting external time code.</i>
632	TC UBIT SELECT	When item 629 is set to “tc,” specify whether to synchronize the user bits of the time code generator to the internal clock. fix : Do not synchronize user bits. time : Synchronize user bits to the internal clock.
633	VITC UBIT SELECT	When item 629 is set to “vitc,” specify whether to synchronize the user bits of the time code generator to the internal clock. fix : Do not synchronize user bits. time : Synchronize user bits to the internal clock.
634	WATCH AUTO ADJUST	When external time code input contains real-time clock user bits, specify whether to adjust the internal clock to match the real-time clock. off : Do not adjust the internal clock to match the real-time clock. on : Adjust the internal clock to match the real-time clock.
651	UMID SDI OUTPUT	Select whether to output UMID in the VANC of the SDI output. off : Do not output. on : Output. <i>See 7-3-3 “Using UMID Data” (page 109) for more information about UMID.</i>



Menu items in the 600s, relating to the time code, metadata, and UMID

Item number	Item name	Settings
652	UMID SDI VANC LINE	Select the line in which UMID is output when menu item 651 is set to "on." 12 H (12 line), 13 H (13 line), 15 H (15 line), 16 H (16 line), 17 H (17 line), 18 H (18 line), 19 H (19 line) (525(U)/525(J) line modes) 9 H (9 line), 10 H (10 line), 12 H (12 line), 13 H (13 line), 14 H (14 line), 15 H (15 line), 16 H (16 line), 17 H (17 line), 18 H (18 line) (625 line mode) <i>See 7-3-3 "Using UMID Data" (page 109) for more information about UMID.</i>
657	ESSENCE MARK SDI OUTPUT	Select whether to output essence marks in the SDI output VANC. off: Do not output. on: Output.
660	ESSENCE MARK SDI VANC LINE	When item 657 is set to "on," select the line to which to output essence marks. 12 H (12 line), 13 H (13 line), 15 H (15 line), 16 H (16 line), 17 H (17 line), 18 H (18 line), 19 H (19 line) (525(U)/525(J) line modes) 9 H (9 line), 10 H (10 line), 12 H (12 line), 13 H (13 line), 14 H (14 line), 15 H (15 line), 16 H (16 line), 17 H (17 line), 18 H (18 line) (625 line mode)

Menu items in the 700s, relating to video control

Item number	Item name	Settings
701	SELECTION OF VIDEO/SYNC DELAY	An E-E video signal is output delayed with respect to the video input signal by the time for video circuit processing. With this item, select whether or not to delay the sync signal attached to the output video signal by an amount corresponding to the video signal delay. sync (sync delay): Delay the sync signal by the corresponding amount before attaching it. video (video delay): Attach a sync signal with the same timing as the input signal.

Menu items in the 700s, relating to video control

Item number	Item name	Settings	
703	BLANK LINE SELECT	Switch blanking of the video output signal on or off for individual lines in the vertical blanking interval. The Y/C signal and odd/even fields are blanked simultaneously.	
	Sub-item		
	1	ALL LINE	-- : Specify the blanking for each line separately. blink (blank) : Regardless of the setting of other sub-items, blank all lines which can be specified in this menu item. thru (throu) : Regardless of the setting of other sub-items, switch off blanking for all lines which can be specified in this menu item.
	2 ... 9	LINE 12 ... LINE 19	In 525(U) line mode Specify blanking for lines 12 to 19. blink (blank) : Carry out blanking. thru (throu) : Switch off blanking.
	10	LINE 20	Specify blanking for line 20. blink (blank) : Carry out blanking. half : Carry out half-blanking. thru (throu) : Switch off blanking.
	2 ... 10	LINE 12 ... LINE 20	In 525(J) line mode Specify blanking for lines 12 to 20. blink (blank) : Carry out blanking. thru (throu) : Switch off blanking.
	11	LINE 21	Specify blanking for line 21. blink (blank) : Carry out blanking. half : Carry out half-blanking. thru (throu) : Switch off blanking.
	2 ... 15	LINE 9, 322 ... LINE 22, 335	In 625 line mode Specify blanking for lines 9, 322 to 22, 335. blink (blank) : Carry out blanking. thru (throu) : Switch off blanking.
16	LINE 23	Specify blanking for line 23. half : Carry out half-blanking. thru (throu) : Switch off blanking.	
705	EDGE SUBCARRIER REDUCER MODE	Select whether to enable the edge subcarrier reducer (ESR). on : Enable. off : Do not enable. When playing back a composite signal, set this to "on."	
707	FORCED VERTICAL INTERPOLATION OFF	The "Y-add" function is normally switched on automatically during jog or variable speed playback. This item selects whether or not to force the "Y-add" function off. auto : Automatically switch the "Y-add" function on. off (forced YADD off) : Force the "Y-add" function off. The "Y-add" function is off while a disc image is displayed in stop mode (menu item 108 "AUTO EE SELECT" is "off"). The "Y-add" function is a circuit operation to interpolate the video signal vertically during jog or variable speed playback for the purpose of reducing the vertical movement of the playback picture.	
710	INTERNAL VIDEO SIGNAL GENERATOR	Select the test signal to be output from the internal test signal generator. When "SG" is selected using the VIDEO INPUT SEL button, the internal test signal generator operates to output the selected test signal. This signal can also be recorded. BB (Black Burst) : Black burst signal CB75 (75% Color Bars) : 75% color bar signal CB100 (100% Color Bars) : 100% color bar signal The factory default settings for each line mode are as follows: In 525(U)/525(J) line modes: CB75 (75% Color Bars) In 625 line mode: CB100 (100% Color Bars)	



Menu items in the 700s, relating to video control

Item number	Item name		Settings
713	VIDEO SETUP REFERENCE		Select whether to remove the setup (7.5%) from the input analog video signals and whether to add the setup (7.5%) to the output analog video signals (when 525(U) or 525(J) line mode is selected).
	Sub-item		
	1	INPUT LEVEL	Whether to remove the setup (7.5%) from the input analog video signals. 0.0% : Do not remove. 7.5% : Remove. The factory default settings for each line mode are as follows: 525(U) line mode: 7.5% 525(J) line mode: 0.0%
	2	OUTPUT LEVEL	Whether to add the setup (7.5%) to the output analog video signals. 0.0% : Do not add. 7.5% : Add. The factory default settings for each line mode are as follows: 525(U) line mode: 7.5% 525(J) line mode: 0.0%
723	INPUT VIDEO BLANK		Switch blanking on or off for individual lines in the vertical blanking interval of an input video signal. The Y/C signal and odd/even fields are blanked simultaneously. A signal with blanking carried out according to this setting is recorded.
	Sub-item		
	1	ALL LINE	- - - : Specify the blanking for each line separately. blnk (blank) : Regardless of the setting of other sub-items, blank all lines which can be specified in this menu item. thru (throu) : Regardless of the setting of other sub-items, switch off blanking for all lines which can be specified in this menu item.
	2 ... 10	LINE 12 ... LINE 20	In 525(U)/ 525(J) line modes Specify blanking for lines 12 to 20. blnk (blank) : Carry out blanking. thru (throu) : Switch off blanking.
2 ... 15	LINE 9, 322 ... LINE 22, 335	In 625 line mode Specify blanking for lines 9, 322 to 22, 335. blnk (blank) : Carry out blanking. thru (throu) : Switch off blanking.	
726	H BLANKING WIDTH		Select the horizontal blanking width of the output analog video signal. narrow (narrow) : Digital blanking (narrow) wide : Analog blanking (wide) When "wide" is selected, the horizontal blanking width complies with RS170A, and normally the blanking is widened and the image becomes narrower. It is recommended to select "narrow" at the editing stage, then later, for broadcast transmission to select "wide," to output a signal conforming to the standard. Note, however, that "narrow" has to be always selected for SDI signals.
728	OUTPUT SCH PHASE		Set the subcarrier H phase. -512 (-512 (DEC))... 0 (0 (DEC))... 511 (511 (DEC))

Menu items in the 700s, relating to video control

Item number	Item name	Settings
731	WIDE MODE	Specify whether to record and play back with the addition of wide picture information.
	Sub-item	
	1 INPUT	Specify whether to save wide picture information on a disc during recording. auto: Automatically record wide picture information when it is detected in the selected input video signal. on: Always record wide picture information. off: Do not record wide picture information.
2 OUTPUT	Specify whether to add wide picture information to the output signal during MPEG IMX playback. thru (through): Output the video signals of the disc being played back without adding wide picture information. auto: When wide picture information is detected on the disc being played back, add wide picture information to the output video signals. Notes <ul style="list-style-type: none"> To add wide picture information to the output signal, it is necessary, in addition to setting this item to “thru,” to operate extended menu item 703 to set line 20 (in 525 line mode) to “thru” or set line 23 (in 625 line mode) to “thru.” In 525 line mode, wide picture information may not be output if VITC signal insertion position is set to line 20 in extended menu item 601 or 602. 	

Menu items in the 800s, relating to audio control

Item number	Item name	Settings
802	DIGITAL AUDIO MUTING IN SHUTTLE MODE	Set the audio muting conditions during shuttle playback. off: Not muted. on: Muted.
807	AUDIO OUTPUT PHASE	Set the output timing of digital audio playback signals (SDI, AES/EBU only), with 80H as a reference position. Output timing is earlier for values smaller than 80H and later for values greater than 80H. (80H, 128 samples = approx. 2.7 ms, 80H, 1 sample = approx. 20 μs) 0 (0 (HEX))... 80 (80 (HEX))... FF (FF (HEX)): Values can be set in this range.
808	INTERNAL AUDIO SIGNAL GENERATOR	Select the operation of the internal audio test signal generator. silnc (silence): Silent signal. 1kHz (1kHz sine): 1 kHz, -20 dB FS sine wave signal. When you select SG as the audio input in the input selection section of the control panel, the audio test signal generated by the internal audio test signal generator is input.
815	AUDIO SAMPLING RATE CONVERTER	Select the mode of operation of the sampling rate converter for AES/EBU input to channels 1 to 4. off: Do not operate. on: Operate.
820	AUDIO OUTPUT CH1/CH2 SELECT	Select the signals to be output from the AUDIO OUT 1/3 and AUDIO OUT 2/4 connectors. line (line out): Output the audio channel signals selected with item 824 “just as they are” from the AUDIO OUT 1/3 and 2/4 connectors. moni (monitor out): Output the monitor audio L-channel (CH-1) and monitor audio R-channel (CH-2) signals from the AUDIO OUT 1/3 and AUDIO OUT 2/4 connectors, respectively.



Menu items in the 800s, relating to audio control

Item number	Item name	Settings	
823	NON-AUDIO FLAG PB	Control non-audio flags in digital audio output.	
	Sub-item		
	1	CH1/CH2	During playback (except E-E mode), set non-audio flags in digital audio output to the following states. on: Set to on (data is non-audio) auto: Set as follows. <ul style="list-style-type: none"> When data is read from disc and confirmed: Follow the data. When data from disc is not confirmed: Maintain current state.
	2	CH3/CH4	
	3	CH5/CH6	
4	CH7/CH8		
824	ANALOG LINE OUTPUT SELECT	Select the analog audio signals (tracks 1 to 8) to be assigned to audio output channels 1 and 2. tr1/2: Tracks 1 and 2 assigned to audio output channels 1 and 2. tr3/4: Tracks 3 and 4 assigned to audio output channels 1 and 2. tr5/6: Tracks 5 and 6 assigned to audio output channels 1 and 2. tr7/8: Tracks 7 and 8 assigned to audio output channels 1 and 2. Note When item 820 is set to "moni," the left channel (CH-1) and right channel (CH-2) of monitor audio are output from the AUDIO OUT 1/3 and 2/4 connectors respectively, regardless of the setting of this item.	
	Sub-item		
827	AES/EBU AUDIO OUTPUT SELECT	Select the audio signals to assign to AES/EBU audio output channels.	
	Sub-item		
	1	CH1/CH2	tr1/2: Tracks 1 and 2 assigned to audio output channels 1 and 2. tr3/4: Tracks 3 and 4 assigned to audio output channels 1 and 2. tr5/6: Tracks 5 and 6 assigned to audio output channels 1 and 2. tr7/8: Tracks 7 and 8 assigned to audio output channels 1 and 2.
	2	CH3/CH4	tr1/2: Tracks 1 and 2 assigned to audio output channels 3 and 4. tr3/4: Tracks 3 and 4 assigned to audio output channels 3 and 4. tr5/6: Tracks 5 and 6 assigned to audio output channels 3 and 4. tr7/8: Tracks 7 and 8 assigned to audio output channels 3 and 4.
828	SDI/DV AUDIO OUTPUT SELECT	Select the audio signals to assign to SDI and i.LINK(AV/C) audio output channels.	
	Sub-item		
	1	CH1/CH2	tr1/2: Tracks 1 and 2 assigned to audio output channels 1 and 2. tr3/4: Tracks 3 and 4 assigned to audio output channels 1 and 2. tr5/6: Tracks 5 and 6 assigned to audio output channels 1 and 2. tr7/8: Tracks 7 and 8 assigned to audio output channels 1 and 2.
	2	CH3/CH4	tr1/2: Tracks 1 and 2 assigned to audio output channels 3 and 4. tr3/4: Tracks 3 and 4 assigned to audio output channels 3 and 4. tr5/6: Tracks 5 and 6 assigned to audio output channels 3 and 4. tr7/8: Tracks 7 and 8 assigned to audio output channels 3 and 4.
831	DV OUT AUDIO MODE	Select the audio mode for i , S400 (i.LINK) connector (output). 4ch: 12 bit/32 kHz/4ch 2ch: 16 bit/48 kHz/2ch	
837	AUDIO MONITOR CHANNEL ARRANGE	Together with item 838, select the audio signals (tracks 1 to 4) to assign to the left and right channels of the audio monitor.	
	Sub-item		
	L-1	Lch/tr1	No display: Do not assign. on: Assign. The factory default settings are as follows. Lch: tr1 Rch: tr2
	L-2	Lch/tr2	
	L-3	Lch/tr3	
	L-4	Lch/tr4	
	R-1	Rch/tr1	
	R-2	Rch/tr2	
	R-3	Rch/tr3	
R-4	Rch/tr4		

Menu items in the 800s, relating to audio control

Item number	Item name	Settings	
838	AUDIO MONITOR CHANNEL ARRANGE	Together with item 837, select the audio signals (tracks 5 to 8) to assign to the left and right channels of the audio monitor. No display: Do not assign. on: Assign. The factory default settings are as follows. Lch: <u>No display</u> Rch: <u>No display</u>	
	Sub-item		
	L-5		Lch/tr5
	L-6		Lch/tr6
	L-7		Lch/tr7
	L-8		Lch/tr8
	R-5		Rch/tr5
	R-6		Rch/tr6
	R-7		Rch/tr7
R-8	Rch/tr8		

Menu items in the 900s, relating to digital process

Item number	Item name	Settings
920	SD-SDI H-ANC CONTROL	Select whether or not to add information to the SDI output. off: Do not add digital audio data channels 5 to 8. on: Add digital audio data channels 5 to 8. off: Do not add RP188 time code data. on: Add RP188 time code data.
	Sub-item	
	1	
	2	RP188 ATC

7-3-2 Extended Menu Operations

The extended menu can be used with the same procedures as in the basic menu.

However, since with the factory default settings the extended menu is not displayed, it is first necessary to enable display of the extended menu.

See “Basic setup menu operations” (page 94) for more information about how to select menu items and how to change their values.

Enabling display of the extended menu

To enable display of the extended menu, an internal switch must be set to on, and extended menu display must be enabled in the maintenance menu. (The internal switch is set to on when the unit is shipped from the factory. Unless you have set it to off, there is no need to change the switch setting.)

To set the internal switch to on

- 1 Using a Phillips screwdriver, remove the cover on the rear panel of this unit

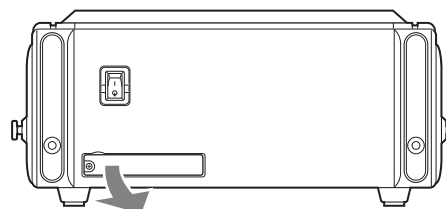

- 2 Use a ballpoint pen or other sharp implement to set the leftmost of the DIP switches on the right side to the ON (top) position.

Note

Do not use a pencil for this operation, as graphite deposits can cause short circuits and lead to failure.

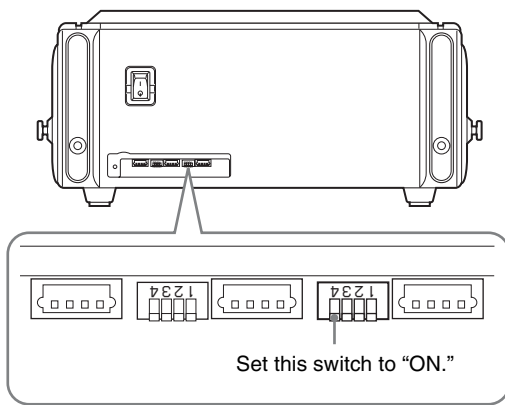

3 Replace the cover.

Note

Tighten the screws firmly.

To enable extended menu display in the maintenance menu

The menu screens in the following procedure are those that appear in the video panel, and on a monitor to which the output of the VIDEO OUT 2 (SUPER)/SDI OUT (SUPER) connector is input.

Proceed as follows.

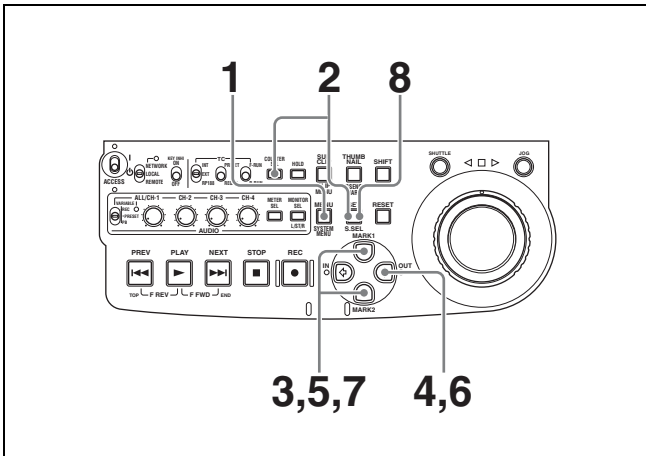

1 Press the MENU button.

The setup menu appears in the video panel and on the external monitor.

2 Hold down the COUNTER SEL button, and press the SET button.

The screen switches to the maintenance menu.

3 Use the \uparrow/\downarrow buttons to select "SETUP MAINTENANCE."

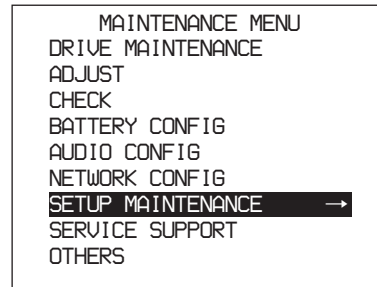

4 Press the \rightarrow button.

5 Use the \uparrow/\downarrow buttons to select "EXTENDED MENU."

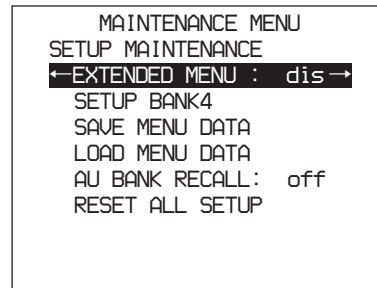

6 Press the \rightarrow button.

7 Press the \downarrow button to select "ENABLE."

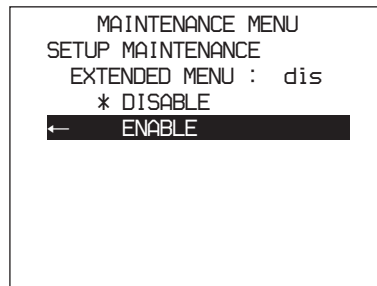

8 Press the SET button.

When you next display the menu and change the item display, the extended menu will appear after the basic menu.

7-3-3 Using UMID Data

To perform operations from interviewing to editing effectively and to detect audio-visual materials easily when reusing them, metadata that provides additional information is recorded along with audio-visual data. As one of application of metadata, the UMID (Unique Material Identifier) is internationally standardized.

What is a UMID?

The UMID (Unique Material Identifier) is a unique identifier for audio-visual material defined by the SMPTE330M-2003 standard.

The UMID may be used either as the 32-byte Basic UMID or as the Extended UMID, which includes an additional 32 bytes of Source Pack to make a total 64 bytes.

For details, refer to SMPTE 330M.

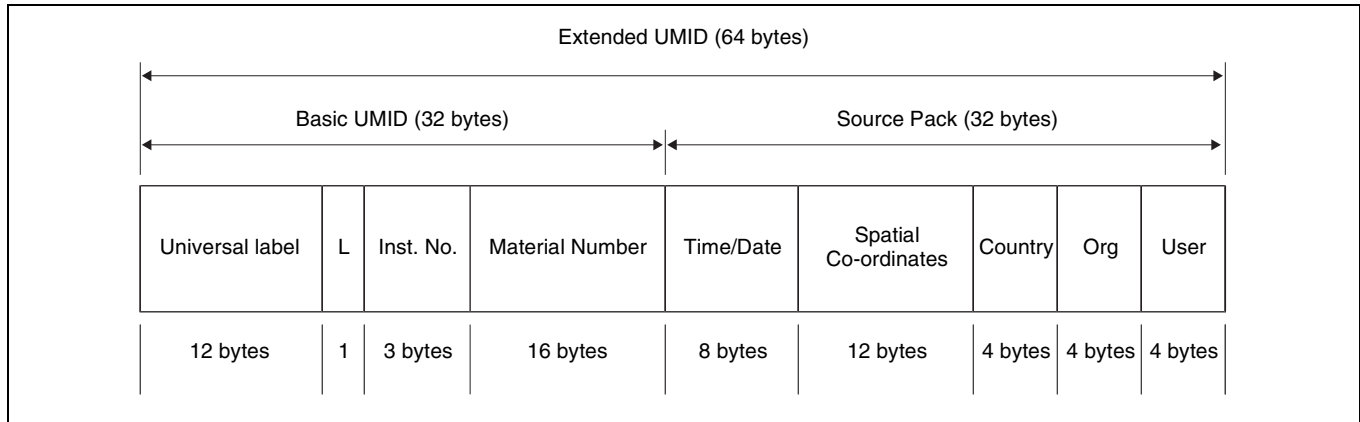

Globally unique ID is automatically recorded in clip units. The Extended UMID is metadata that provides additional information such as location, time/date, company and so on.

The UMID is applied as follows.

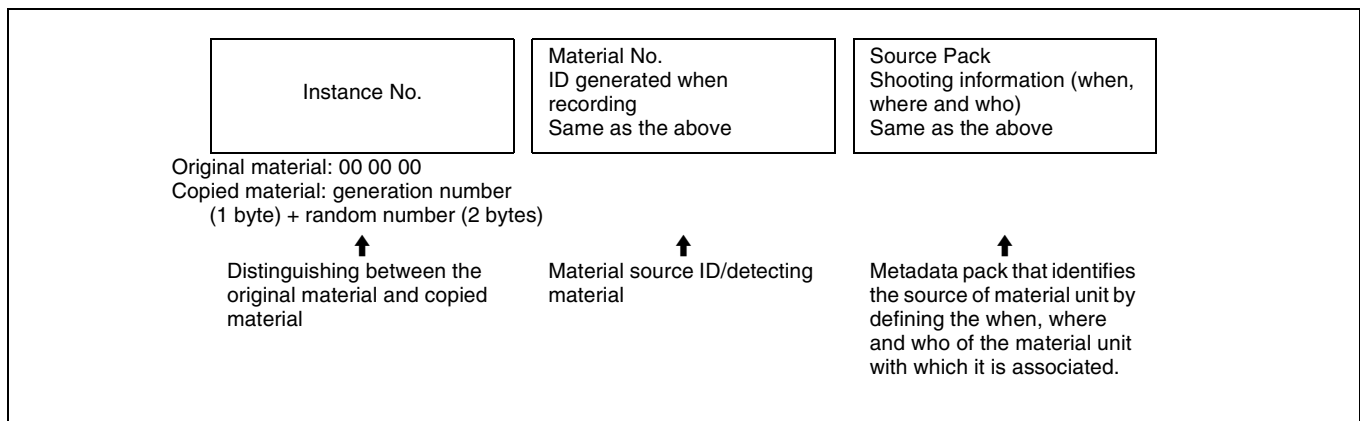

Using the Extended UMID

You have to enter a country code, organization code and user code. Set the country code referring to the ISO-3166 table, and set the organization code and user code independently.

For details, see “About UMID ownership information” (page 111).

Functions of UMID data

The UMID data enables the followings:

- Add a globally unique ID to every clip of audio-visual material. The unique ID is used to detect the material source and to link it with the original source material.
- Distinguishing between original material and copied material. 00 is added to the Instance Number for original material.

- Recording based on the UTC. The UTC is used when recording the UMID. This enables uniform control of source material recorded all over the world based on the universal time code.
- Calculating the date difference among source materials. The source material is recorded based on the MJD (Modified Julian Date), which enables easy calculation of date difference among source materials.

Setting UMID ownership information

Proceed as follows.

- 1 Set extended menu item 029 “STORED OWNERSHIP” to “on.”

See 7-2-2 “Basic Menu Operations” (page 94) for more information about how to make this setting.

2 Set the following item.

Item	Contents
COUNTRY	Country code
ORGANIZATION	Organization code
USER	User code

To change the currently selected item

Hold down the STOP button, and turn the jog dial or shuttle dial.

To select a different digit to be changed

Turn the jog dial or shuttle dial.

To change the value of a digit

Hold down the SHUTTLE button, and turn the jog dial or shuttle dial.

3 Press the SET button.

About UMID ownership information

COUNTRY (country code)

Enter an abbreviated alphanumeric string (4-byte alphanumeric strings) according to the values defined in ISO 3166-1.

There are about 240 country codes.

Find your own country code on the following home page.

Refer to ISO-3166-1:

<http://www.evertype.com/standards/iso3166/iso3166-1-en.html>

When the country code is less than 4 bytes, the active part of the code will occupy the first part of the 4-bytes and the remainder must be filled with the space character (20h).

Example: In the case of Japan

For Japan, if the country code is JP, it is 2 bytes, if JPN, it is 3 bytes.

Thus, enter the following:

JP _ _

or

JPN _

where _ represents a space.

ORGANIZATION (organization code)

Enter an abbreviated 4-byte alphanumeric string for the organization code.

Notes

- Organization codes must be acquired by applying to the SMPTE registration office.

When no organization code has been acquired, it is forbidden to enter an arbitrary string. As a rule, the code “00” must be entered. Freelance operators who do not belong to an origination should enter “.”.

- There are no problems in recording or playing back audio-video signals, if ORGANIZATION is not set.

USER (user code)

Enter the 4-byte alphanumeric strings for user identification.

The user code is registered with each organization locally. It is usually not centrally registered.

When the country code is less than 4 bytes, enter the country code from the beginning of the 4 bytes and enter the space character (20h) in the remaining strings.

This user code is determined by the organization. The methods used depend on the organization.

Note

User code cannot be entered when no organization code has been entered.

7-4 Maintenance Menu

7-4-1 Items in the Maintenance Menu

The following tables show the items in the maintenance menu.

- Item names are the names which appear in the video panel, and on an external monitor to which the output of the VIDEO OUT 2 (SUPER)/SDI OUT (SUPER) connector is input.
- The values in the Settings columns are the values which appear in the time data display section. (The values may

appear in a different format in the video panel and on an external monitor. In this case, the video panel values are shown in parentheses.) Underlined values are the factory defaults.

For information about the DRIVE MAINTENANCE, ADJUST, CHECK, BATTERY CONFIG and SERVICE SUPPORT items, refer to the Maintenance Manual.

AUDIO CONFIG: items relating to audio control

Item	Setting
METR HEAD ROOM	Select the audio reference level (headroom). <u>-12dB</u> , -16dB, -18dB, <u>-20dB</u> (525(U)/525(J) line modes) -12dB, -16dB, -18dB, <u>-20dB</u> , EBUL (625 line mode)
DATA LENGTH	When "IMX50," "IMX40," or "IMX30" is selected in setup menu item 031, this selects the audio quantization bit count and number of recording channels. <u>16×8 (16bit × 8ch)</u> : 16 bits × 8 channels <u>24×4 (24bit × 4ch)</u> : 24 bits × 4 channels Note When item 031 is set to "DVCAM," the setting is automatically fixed at 16 bits × 4 channels.
NON-AUDIO INPUT	Select whether to handle digital audio signals as non-audio signals during recording.
Sub-item	Audio (audio) : Handle as audio signals. data : Handle as non-audio signals.
tr1/tr2	
tr3/tr4	
tr5/tr6	
tr7/tr8	
INPUT LEVEL	Set the upper limit for the signal level input to audio channels 1/3 or 2/4. <u>+4dB</u> , 0dB, -3dB, -6dB (525(U)/525(J) line modes) <u>+4dB</u> , 0dB, -3dB, -6dB, EBUL (625 line mode)
Sub-item	
CH1/CH3	
CH2/CH4	
OUTPUT LEVEL	Set the reference level for audio output signals. <u>+4dB</u> , 0dB, -3dB, -6dB (525(U)/525(J) line modes) <u>+4dB</u> , 0dB, -3dB, -6dB, EBUL (625 line mode)

NETWORK CONFIG: items relating to network settings

Item	Setting
DHCP	Set whether to assign an IP address automatically with the DHCP server. DISABLE : Do not assign automatically. ENABLE : Assign automatically.
IP ADDRESS PRESET	Set IP address. <u>192.168.001.010</u> Note When DHCP is set to "ENABLE," it is not possible to set the IP address.



NETWORK CONFIG: items relating to network settings

Item	Setting
SUBNET MASK PRESET	Set the subnet mask. 255.255.255.000 Note When DHCP is set to “ENABLE,” it is not possible to set the subnet mask.
DEFAULT GATEWAY PRESET	Set the default gateway. 000.000.000.000 Note When DHCP is set to “ENABLE,” it is not possible to set the default gateway.
LINK SPEED	Set the communications speed. AUTO, 10Mbps, 100Mbps
DUPLEX	Set the communications method. AUTO, Full (Full Duplex), Half (Half Duplex)

For details of how to make settings, see “To change network settings” (page 115).

SETUP MAINTENANCE: items relating to the setup menu

Item	Setting
EXTENDED MENU	Select whether or not to display the extended menu. DISABLE: Do not display. ENABLE: Display.
SETUP BANK4	Select the bank to be stored in menu bank 4, or reset menu bank 4. Cur to 4 (CURRENT TO BANK4): Store the current menu settings in menu bank 4. 1 to 4 (BANK1 TO BANK4): Store the menu bank 1 settings in menu bank 4. 2 to 4 (BANK2 TO BANK4): Store the menu bank 2 settings in menu bank 4. 3 to 4 (BANK3 TO BANK4): Store the menu bank 3 settings in menu bank 4. Reset (RESET BANK4): Reset menu bank 4.
SAVE MENU DATA	Select whether to temporarily back up (save) setup menu settings before operations such as software upgrades. SET button: Back up (save) the settings. MENU button: Return to next highest menu level without backing up.
LOAD MENU DATA	Select whether to restore (load) setting that were backed up (saved) with the “SAVE MENU DATA” item. SET button: Restore (load) the settings. MENU button: Return to the next highest menu level without restoring.
AU BANK RECALL	Select whether to recall settings automatically from a menu bank when the system is powered on, and if so which menu bank to recall from. off: Do not recall settings from a menu bank. Bank1 (from BANK1): Recall settings from menu bank 1. Bank2 (from BANK2): Recall settings from menu bank 2. Bank3 (from BANK3): Recall settings from menu bank 3. Bank4 (from BANK4): Recall settings from menu bank 4.
RESET ALL SETUP	Reset the current menu settings to the factory settings. SET button: Reset. MENU button: Return to the next highest menu level without resetting. Notes <ul style="list-style-type: none"> • The line mode setting is also cleared. If you execute this item, reset the line mode (see page 7). • Date and time settings are not cleared, but the time zone setting is cleared. After executing this item, reset the time zone (see page 34).

OTHERS

Item	Setting
SDI SUPER	Select whether to output superimpose characters to the SDI OUT (SUPER) connector. ON: Output. OFF: Do not output.

For details about OTHERS items other than the above, refer to the Maintenance Manual.

7-4-2 Maintenance Menu Operations

Basic maintenance menu operations

The following explains how to select maintenance menu items and how to change their values. The menu screen shown are those that appear in the video panel and on a monitor to which the output of the VIDEO OUT 2 (SUPER)/SDI OUT (SUPER) connector is input. First change the switch setting within the unit, then carry out the following operations.

For information about how to change the switch setting within the unit, see page 108.

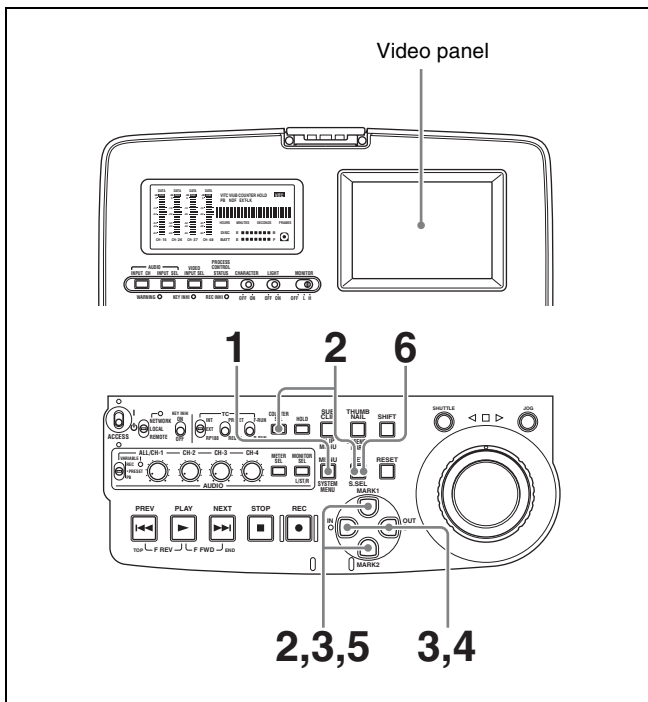

1 Press the MENU button.

The menu appears in the video panel and on the external monitor.

2 Hold down the COUNTER SEL button, and press the SET button.

The group selection screen of the maintenance menu appears. The currently selected item group is

highlighted, and the arrow (→) flashes to indicate that you can move to a lower-level menu.

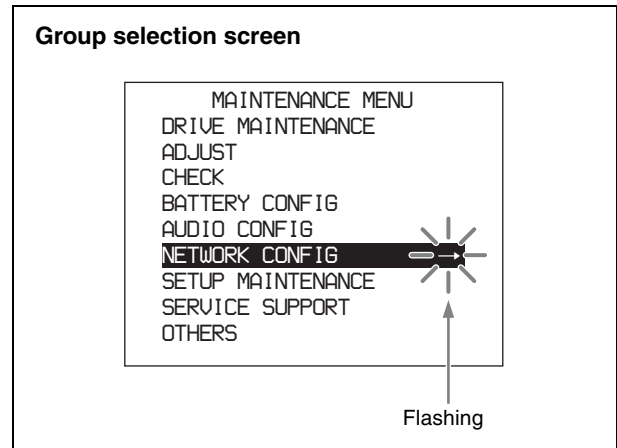

To select the item group

Use the ⇄ buttons.

3 Press the ⇄ button.

A lower-level menu (item selection screen) appears. The currently selected item is highlighted, and the arrow (←/→) flashes to indicate that you can move to a higher- or lower-level menu.

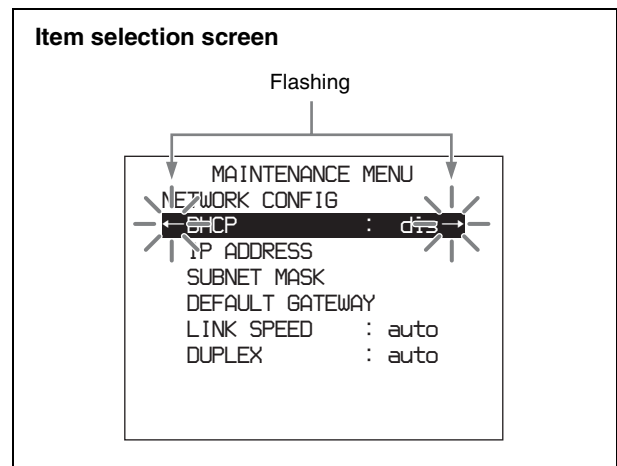

To return to the item group

Press the ⇄ button.

To select the menu item

Use the ⇄ buttons.

4 Press the ⇨ button.

A lower-level menu (setting modification screen) appears. The current setting is highlighted, and the arrow (←) flashes to indicate that you can move to a higher-level menu. If the current setting is the factory default, a colon (:) appears between the item name and the setting. A midpoint (•) appears if you change the factory default setting to another value and then display the setting modification screen again.

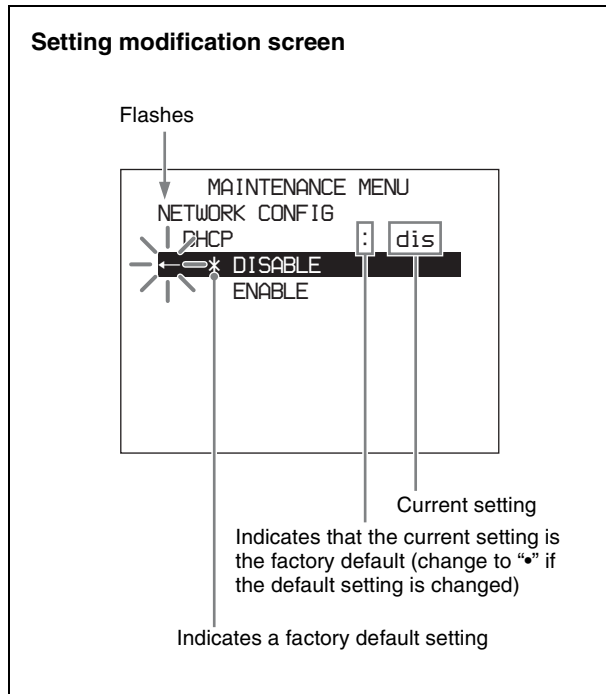

To return to the menu item

Press the ⇨ button.

When there is a sub-item

Repeat steps **3** and **4** until the setting modification screen appears.

5 Using the ⇧/⇩ buttons to select the desired setting.

6 Press the SET button.

This saves the new setting, and the menu disappears from the video panel or an external monitor.

To cancel changing a setting

Before pressing the SET button, press the MENU button.

The menu disappears from the video panel or an external monitor, without saving the new setting.

To change network settings

To change network settings, carry out steps **1** to **3** in the procedure of “Basic maintenance menu operations” above, to display the NETWORK CONFIG menu item, then carry out the following operations.

For details of the settings, consult your network administrator.

When the IP address is assigned automatically

Check that the network cable is connected to this unit before carrying out the operation.

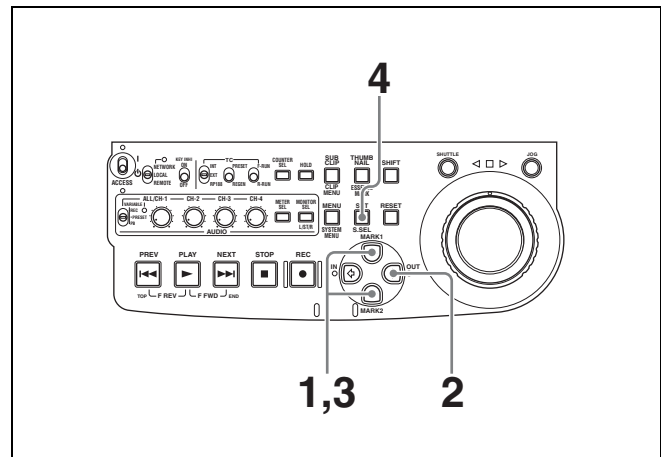

1 Using the ⇧/⇩ buttons to select “DHCP.”

2 Press the ⇨ button.

3 Press the ⇩ button to select “ENABLE.”

4 Press the SET button.

To check the assigned IP address

In the NETWORK CONFIG menu, using the ⇧/⇩ buttons to select “IP ADDRESS,” then press the ⇨ button.

Note

If the IP address cannot be assigned, this is shown as “000.000.000.000.” In this case, consult the network administrator.

To set the IP address

First set DHCP to “DISABLE.” (See the previous item, “When the IP address is assigned automatically.”)

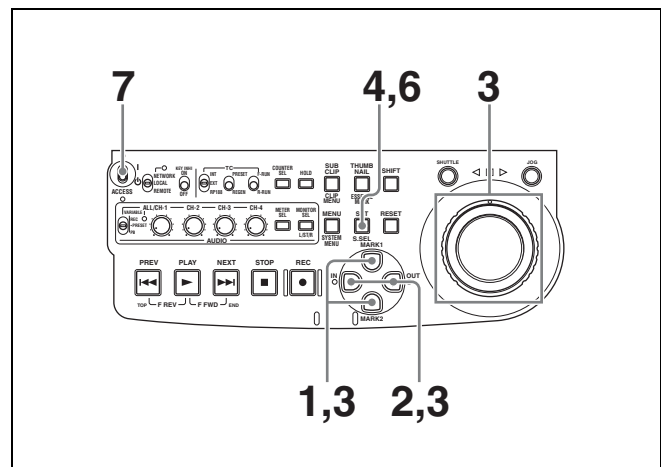

1 Using the \leftarrow/\rightarrow buttons to select “IP ADDRESS.”

2 Press the \leftrightarrow button.

The IP ADDRESS PRESET menu appears, and the digit that can be changed flashes.

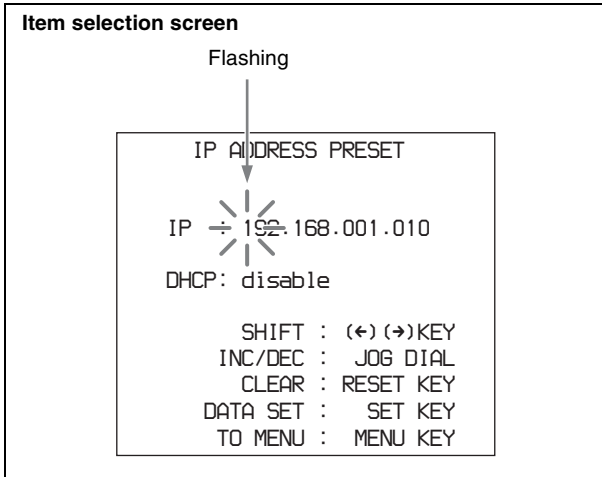

3 Set the IP address.

To select a different digit to be changed

Use the \leftrightarrow buttons.

To change the value of a digit

Turn the jog dial or shuttle dial.

Turning clockwise increases the value, and turning counterclockwise decreases the value.

The \leftarrow/\rightarrow buttons can be used.

To return to the factory default setting

Press the RESET button.

4 When all digits are set, press the SET button.

This returns to the NETWORK CONFIG menu.

To cancel a setting

Before pressing the SET button, press the MENU button.

This returns to the NETWORK CONFIG menu, without saving the new setting.

5 Repeat steps **1** to **4** as required, to set the subnet mask and default gateway.

6 In the NETWORK CONFIG menu, press the SET button.

7 When the “NOW SAVING...” message vanishes, power the unit off and then on again with the on/standby switch.

Setting the communications speed

Set the communications speed (LINK SPEED) and communications method (DUPLEX) to match the network environment.

For details of the operation, see “Basic maintenance menu operations” (page 114).

7-5 System Menu

7-5-1 Items in the System Menu

The following tables show the items in the system menu. Item names are the names which appear in the video panel, and on an external monitor to which the output of the

VIDEO OUT 2 (SUPER)/SDI OUT (SUPER) connector is input.

DISC MENU: items relating to disc

Item	Setting
STATUS	Display disc status or clip status.
Sub-item	Note Although the PDZ-1 Proxy Browsing Software can write TITLE1 and TITLE2, only TITLE1 is displayed here.
1 DISC	Display disc status.
2 CLIP	Display clip status.
DELETE	Delete clips on the disc.
Sub-item	
1 LAST CLIP	Delete the last clip.
2 ALL CLIP	Delete all the clips. (Locked files and files in the General directory cannot be deleted.)
FORMAT	Select the disc format, and carry out formatting.
Sub-item	
1 QUICK FORMAT	Quick format (Deletes all data on the disc, including the contents of the General directory.)

DATE/TIME PRESET: items relating to date and time setting

Item	Setting
YEAR	Set the year, month, day, time, and time zone.
MONTH	
DAY	
TIME	
TIME ZONE	

7-5-2 System Menu Operations

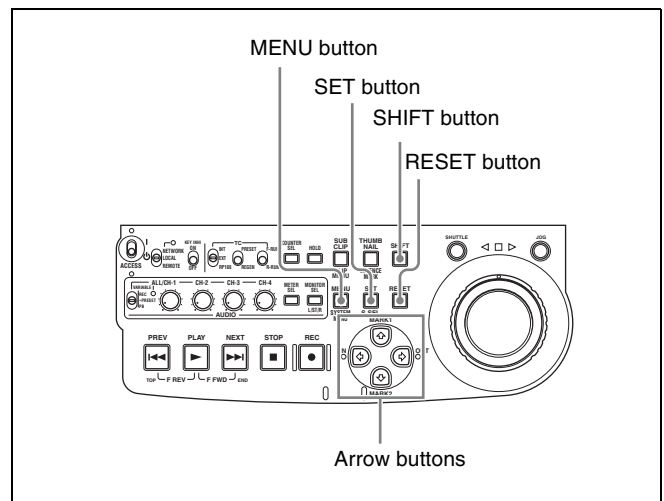

To display disc status and clip status

Insert a disc and proceed as follows.

- 1 Hold down the SHIFT button and press the MENU button.

The system menu appears in the video panel or on an external monitor.

- 2 Press the \uparrow button or \downarrow button to select “DISC MENU,” then press the \rightarrow button.

The DISC MENU page appears.

- 3 Press the \uparrow button or \downarrow button to select “STATUS,” then press the \rightarrow button.

The “STATUS” menu item appears.

- 4 Display the disc status or the status of the current clip.

To display the disc status

Press the \uparrow button or \downarrow button to select “DISC,” then press the \rightarrow button.

The status of the loaded disc appears.

```
DISC STATUS
USER ID:   (no ID)
TITLE :   (no name)

REMAIN    : 029 min
REWRITE   : 0002 times
SALVAGE   :      OK
FILE SYSTEM :      OK

TO MENU : MENU KEY
```

To display the status of the current clip

Press the \uparrow button or \downarrow button to select “CLIP,” then press the \rightarrow button.

The status of the clip at the current position appears. (When the current clip changes because of playback or a search, the display switches to the status of the new clip.)

```
CLIP STATUS
CLIP NO   : 001/010
NAME      : C0001
TITLE     : (no name)
RECORD DEVICE: PDW-R1
SERIAL    : 10001
DATE      : 01/01/06
TIME      : 19:54:38

TO MENU : MENU KEY
```

To return to the previous menu page

Press the MENU button.

To exit the menu system

Press the MENU button twice.

To delete clips

Notes

- Clips cannot be deleted when the Write Inhibit tab of the disc is set to the recording disabled position, or when extended menu item 310 “REC INHIBIT” is set to “on.”
- Locked clips (*see page 55*) are not deleted.

Proceed as follows.

- 1 Carry out steps 1 and 2 in the previous section “To display disc status and clip status.”

- 2 Press the \uparrow button or \downarrow button to select “DELETE,” then press the \rightarrow button.

The “DELETE” menu item appears.

- 3 Delete the last clip or all clips.

To delete the last clip

Press the \uparrow button or \downarrow button to select “LAST CLIP,” then press the \rightarrow button.

The name of the clip to be deleted appears.

To cancel the deletion and return to the previous page, press the MENU button.

To delete all clips

Press the \uparrow button or \downarrow button to select “ALL CLIP,” then press the \rightarrow button.

The message “ALL DELETE OK?” appears.

To cancel the deletion and return to the previous page, press the RESET button.

To cancel the deletion and exit the menu system, press the MENU button.

- 4 Press the SET button.

The last clip is deleted, or all clips are deleted.

You can use the THUMBNAIL MENU to delete the selected clip or all clips. For details, see page 56.

To format discs

See 3-6-5 “Formatting a Disc” (page 39).

To set the date and time

See 3-4 “Setting the Date and Time” (page 34).



Maintenance and Troubleshooting

Chapter

8

8-1 Periodic Maintenance

8-1-1 Digital Hours Meter

The digital hours meter can provide six items of information about the operational history of the unit. This information appears in the time data display section, in the video panel, and on an external monitor to which the output of the VIDEO OUT 2 (SUPER)/SDI OUT (SUPER) connector is input. Use the information as a guide in scheduling periodic maintenance.

For periodic maintenance, consult your Sony dealer.

Display modes of the digital hours meter

H01: OPERATION mode

Displays the total number of hours the unit has been powered on in units of 1 hour.

H11: OPERATION mode (resettable)

Same as H01 except that the count is resettable. This can be used as a guide in determining when to replace parts.

H12: LASER PARAMETER mode (resettable)

This shows a counter of the cumulative light output time by the optical head in units of hours.¹⁾ The count is resettable.

This can be used as a guide in determining when to replace the optical head.

1) The counter advances at different rates during recording and playback. It is also affected by the ambient temperature.

H13: SEEK RUNNING mode (resettable)

This shows the cumulative seek operation time for the optical head in units of hours. The count is resettable. This can be used as a guide in determining when to replace the seek motor.

H14: SPINDLE RUNNING mode (resettable)

This shows the cumulative spindle rotation time, in units of hours. The count is resettable.

This can be used as a guide in determining when to replace the spindle motor.

H15: LOADING COUNTER mode (resettable)

Display the total number of times disc has been loaded in the unit. The count is resettable.

To display the digital hours meter

Press the MENU button, then turn the jog dial or shuttle dial to display the required item in the time data display and in the video panel or on an external monitor.

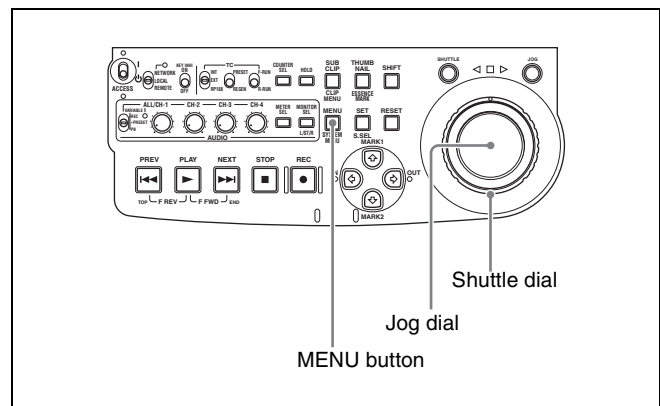

To exit from the digital hours meter

Press the MENU button.

To jump to H01

Press the MENU button, then the COUNTER SEL button. Every time you press the COUNTER SEL button, menu item H01 or B01 is recalled alternately.

8-2 Condensation

When this unit is moved from a cold place to a warmer place, or operated in high humidity, condensation may form on the optical pickup. This is called condensation, and if the unit is operated in this state, it may make correct recording and playback impossible.

Note the following points, to avoid problems with condensation.

- When moving the unit under conditions in which condensation is likely, first insert the disc, and close the lid on the disc slot.
- If when you move the on/standby switch to the I position the indication “HUMID” appears in the status display, do not insert a disc until the indication disappears.

8-3 Error Messages

Error codes appear in the time data display when an error (usually a hardware problem) occurs. Error codes and error messages appear in the video panel, and on an external monitor to which the output of the VIDEO OUT 2 (SUPER)/SDI OUT (SUPER) connector is input.

When an error message appears, follow the instructions in the error message to resolve the problem.

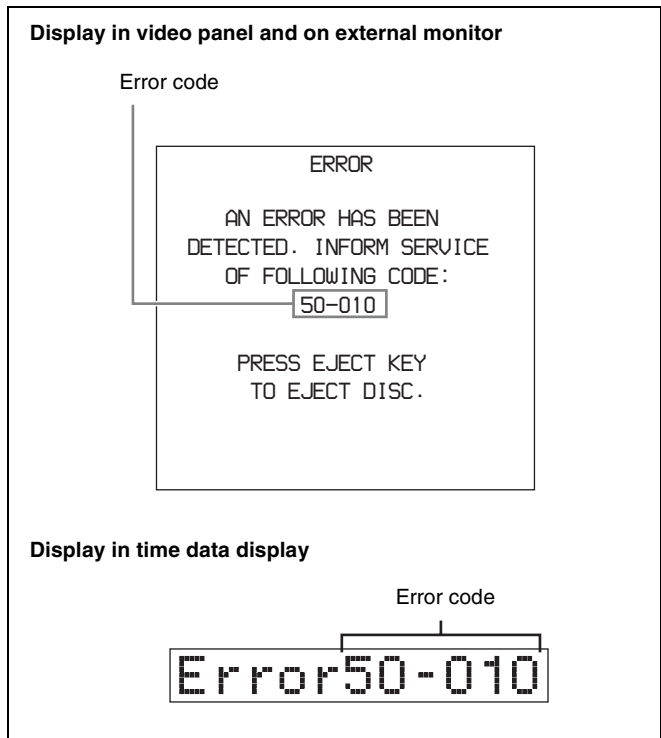

8-4 Alarms

An alarm (warning message) appears in the time data display when an operation is attempted which is inappropriate for the settings on this unit or the state of the disc. The video panel and an external monitor to which the output of the VIDEO OUT 2 (SUPER)/SDI OUT (SUPER) connector is input displays the alarm message and also the action to take to resolve the problem.

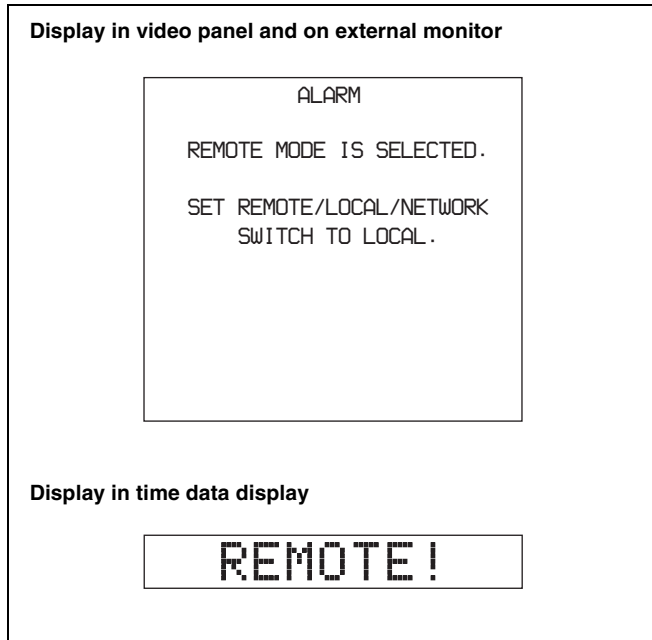

8-4-1 Alarm List

The following tables list the alarms displayed by this unit, categorized according to the state of the unit when the alarms occur.

The setting of basic menu item 016 “ALARM DISPLAY” determines whether or not some of these alarms appear. The “Display condition” column in the tables shows whether the alarm is displayed according to or regardless of the setting of menu item 016.

See 7-2-2 “Basic Menu Operations” (page 94) for more information about how to set menu item 016.

When the unit is powered on

Message in time data display	Display condition ^{a)}	Description	Action
MENU Ver.UP	on, limit, off	Setup menu settings were reset, because this unit was upgraded.	Reset the setup menu items. <i>See 7-2-2 "Basic Menu Operations" (page 94) and 7-3-2 "Extended Menu Operations" (page 108) for information about making setup menu settings.</i> <i>Maintenance menu item "SETUP MAINTENANCE" - "SAVE MENU DATA/LOAD MENU DATA" (see page 113) can be used to temporarily back up and restore the current menu settings.</i>
ILL. SETUP!	on, limit, off	Setup menu data is invalid, or data recalled with the maintenance menu item "SETUP MAINTENANCE" – "AUTO BANK RECALL" is invalid.	Reset the items in the setup menu.
Exchg batt!	on, limit, off	NVRAM battery is exhausted.	It is time to exchange the battery on the board. Contact your Sony service representative.
LOW BATT!	on, limit, off	Battery pack power is low.	Exchange with a charged battery pack.
BATT EMPTY!	on, limit, off	Battery pack power is exhausted.	<i>See 3-2-3 "Using a Battery Pack" (page 33) for more information about exchanging battery packs.</i>

a) With respect to setting of basic menu item 016

When a disc is inserted

Message in time data display	Display condition ^{a)}	Description	Action
Unknown FS!	on, limit, off	The loaded disc was formatted by an unknown file system.	Eject or format the disc. <i>See 3-6-5 "Formatting a Disc" (page 39) for more information about formatting.</i>
No FS!	on, limit, off	The file system cannot be detected.	Eject the disc.
ILL. Disc!	on, limit, off	An unsupported disc was inserted.	
Salvage NG	on, limit, off	Recovery of disc contents (salvage) failed.	<i>See 3-6-7 "Handling of Discs When Recording Does Not End Normally (Salvage Function)" (page 40).</i>
525/60 Clip	on, limit	A disc recorded in NTSC format was inserted when this unit is in 625 line mode (PAL system).	Use a disc recorded with the PAL system.
625/50 Clip	on, limit	A disc recorded in PAL format was inserted when this unit is in 525(U) or 525(J) line mode (NTSC system).	Use a disc recorded with the NTSC system.
IMX50 Clip IMX40 Clip IMX30 Clip DVCAM Clip	on, limit	The recording format of the loaded disc differs from the format specified with basic menu item 031 "RECORDING FORMAT."	To record on the disc, change the setting of basic menu item 031. <i>See 7-2-2 "Basic Menu Operations" (page 94) about how to change this setting.</i>

Message in time data display	Display condition ^{a)}	Description	Action
4CHx24 Clip 8CHx16 Clip	on, limit	The number of channels and quantizing bits of the loaded disc differ from the specifications of maintenance menu item "AUDIO CONFIG" - "DATA LENGTH."	To record on the disc, change the setting of maintenance menu item "AUDIO CONFIG" - "DATA LENGTH." <i>See 7-4-2 "Maintenance Menu Operations" (page 114) about how to change this setting.</i>
No Support!	on, limit, off	A disc recorded in an unsupported recording format was inserted.	Use a disc recorded in the MPEG IMX or DVCAM format.
ILL. Index!	on, limit, off	An index file error was detected.	Format the disc. <i>For details, see 3-6-5 "Formatting a Disc" (page 39).</i>
FORMAT NG!	on, limit, off	Automatic format failed.	Use another disc.
DI read err	on, limit, off	A disc read error occurred.	Try ejecting the disc and inserting it again, or insert another disc.
DRV ADJ err	on, limit, off	Adjustment processing failed when a disc was inserted.	

a) With respect to setting of basic menu item 016

During playback

Message in time data display	Display condition ^{a)}	Description	Action
525/60 Disc	on, limit	An attempt was made to play back a disc recorded with the NTSC system when this unit is in 625 line mode (PAL system).	Use a disc recorded with the PAL system.
625/50 Disc	on, limit	An attempt was made to play back a disc recorded with the PAL system when this unit is in 525(U) or 525(J) line mode (NTSC system).	Use a disc recorded with the NTSC system.
Disc Error!	on, limit, off	Normal playback is not possible because of a disc defect.	Use another disc. You can check the state of a disc by checking playback condition marks (see page 36).

a) With respect to setting of basic menu item 016

During control panel operations

Message in time data display	Display condition ^{a)}	Description	Action
KEY INHI.!	on	An operation button inhibited by extended menu item 118 "KEY INHIBIT" was pressed while the KEY INH indicator was lit.	Set the corresponding sub-item of extended menu item 118 to "off." <i>See 7-3-2 "Extended Menu Operations" (page 108) about how to make this setting.</i>
REMOTE!	on	A button was pressed while the remote control switch was set to "REMOTE."	To operate from the front panel, wait until control by the remote device ends and then set the remote control switch to "LOCAL."

Message in time data display	Display condition ^{a)}	Description	Action
No Disc!	on	A button was pressed with no disc loaded.	Operate after inserting a disc.
No Disc!	on, limit, off	An attempt to delete a clip was made with no disc loaded.	
No Disc!	on, limit, off	An attempt to format a disc was made with no disc loaded.	
REC INHI.!	on	An attempt was made to record, display an E-E picture, record an essence mark, or add a quick scene selection sub clip.	To perform these operations on the disc, set the Write Inhibit tab of the disc to the recording enabled position.
REC INHI.!	on	An attempt was made to record, display an E-E picture, record an essence mark, or add a quick scene selection sub clip while extended menu item 310 "REC INHIBIT" was set to "on."	To perform these operations, set extended menu item 310 to "off." <i>See 7-3-2 "Extended Menu Operations" (page 108) about how to make this setting.</i>
IMX50 Clip IMX40 Clip IMX30 Clip DVCAM Clip 4CHx24 Clip 8CHx16 Clip	on, limit	A recording or E-E display operation was attempted on a disc recorded in a format different from the setting of basic menu item 031 "RECORDING FORMAT."	To perform these operations on the disc, change the setting of basic menu item 031. <i>See 7-2-2 "Basic Menu Operations" (page 94) about how to change this setting.</i>
REC INHI.!	on, limit	An attempt to save the current clip list was made while the REC INHI indicator was lit.	To perform these operations, cancel all of the following write-protect settings. <ul style="list-style-type: none"> • Write Inhibit tab of the disc • Setting of extended menu item 310 "REC INHIBIT" • Mismatch between the recorded sections of the disc and the setting of basic menu item 031 "RECORDING FORMAT"
REC INHI.!	on, limit, off	An attempt to delete a clip was made while the REC INHI indicator was lit.	
REC INHI.!	on, limit, off	An attempt to format a disc was made while the REC INHI indicator was lit.	
No Clip!	on, limit	A playback or search button was pressed for a disc containing no recorded clips.	These operations are not possible.
No Clip!	on, limit, off	An attempt was made to delete a clip from a disc containing no recorded clips.	
Disc Top!	on	The PREV button was pressed while stopped at the top of the disc, or an attempt was made to perform a high-speed reverse search.	
Disc End!	on	The NEXT button was pressed while stopped at the end of the disc, or an attempt was made to perform a high-speed forward search.	
MAX # Files	on, limit, off	The number of files on the disc had reached the upper limit (5000), or there was not enough capacity in the General directory when an attempt was made to record, display an E-E picture, record an essence mark, or add a quick scene selection sub clip.	
Disc Full!	on, limit, off	An attempt was made to record or display an E-E picture when there was not enough free capacity on the disc, or when the number of recorded clips had reached the upper limit (300).	

Message in time data display	Display condition ^{a)}	Description	Action
MAX# SB CLP	on, limit, off	An attempt was made to add a sub clip when the number of registered sub clips had already reached the upper limit (300) of the specifications of this unit.	These operations are not possible.
CL OVER DUR	on, limit, off	An attempt was made to add a sub clip when the total duration of sub clips in the clip list had already reached the upper limit (24 hours) of the specifications of this unit.	
Run Salvage	on, limit, off	An attempt was made to record, display an E-E picture, record an essence mark, or add a quick scene selection sub clip on a disc which requires clip recovery (salvage).	Try the operation again after executing the salvage function. <i>For details, see 3-6-7 "Handling of Discs When Recording Does Not End Normally (Salvage Function)" (page 40).</i>
CNT mode!	on	A time code or user bits preset operation was attempted with "COUNTER" selected by the COUNTER SEL button.	Try the operation again after selecting "TC" or "UB" with the COUNTER SEL button.
TC EXT!	on	A time code or user bits preset operation was attempted with the INT/EXT/RP188 switch is set to EXT and the PRESET/REGEN switch is set to PRESET.	Try the operation again after setting the INT/EXT/RP188 switch to INT and the PRESET/REGEN switch to PRESET.
REGEN mode!	on	A time code or user bits preset operation was attempted with the PRESET/REGEN switch is set to REGEN.	<i>See 7-3-2 "Extended Menu Operations" (page 108) about how to make this setting.</i>
REC-PAUSE!	on	A time code or user bits preset operation was attempted with recording paused.	Try the operation again after stopping recording.
REC mode!	on, limit	An attempt was made to switch video or audio signals during recording.	
REC mode!	on, limit, off	An attempt was made to display the system menu "DISC MENU" during recording.	
REC mode!	on, limit	The THUMBNAIL button was pressed during recording.	
REC mode!	on, limit, off	An attempt was made to display DRIVE MAINTENANCE in the maintenance menu during recording.	
No SEL List	on, limit	The SUBCLIP button was pressed without loading a clip list from the disc into the current clip list.	Try the operation again after loading a clip list. <i>For details, see 5-3-1 "Loading a Clip List From Disc Into Unit Memory" (page 68).</i>
No SUB Clip	on, limit	A button in the playback control section was pressed when there were no sub clips in the current clip list.	Playback is not possible without a sub clip in the current clip list.
SB CLP mode	on, limit	The SHIFT button and the THUMBNAIL button were pressed together with the SUBCLIP button lit.	Press the SUBCLIP button, turning it off, and try the operation again.
SUB CLIP NG	on, limit	The SHIFT and SET buttons were pressed together when IN and OUT points were not set correctly (the OUT point was set before the IN point, etc.).	Set the IN and OUT points correctly and try the operation again.
No List!	on, limit, off	An attempt was made to delete a clip list with no clip lists saved on the disc.	This operation is not possible.

Message in time data display	Display condition ^{a)}	Description	Action
STOP ONCE!	on, limit	The SUBCLIP button was pressed during playback of a clip list.	Try the operation again after stopping playback.
STOP ONCE!	on, limit, off	An attempt was made to display the CLIP menu during playback.	
No EM Space	on, limit, off	Recording of an essence mark failed because the number of essence marks recorded on the disc reached the upper limit of the specifications of this unit.	Use the PDZ-1 Proxy Browsing Software to delete unneeded essence marks.
EM Full!	on, limit, off	An attempt was made to add an essence mark with the number of recorded essence marks at the upper limit of the specifications of this unit.	
Formatting!	on, limit, off	An attempt was made to display the DISC MENU page in the system menu during an auto format.	Wait until the end of the auto format.
Disc Damage	on, limit, off	An attempt was made to record, display an E-E picture, record an essence mark, or add a quick scene selection sub clip when there was no free sparing area.	This disc cannot be recorded. Exchange the disc.
Non AV Full	on, limit, off	An attempt was made to record, display an E-E picture, record an essence mark, or add a quick scene selection sub clip when there was no free Non-Real-Time space.	Insert a different disc with enough free capacity.
Index File!	on, limit, off	An attempt was made to record to a disc containing an unsupported index file.	Exchange the disc for one that contains an index file supported by this unit. Alternatively, format the disc (see page 39).
File System	on, limit, off	An attempt was made to record to a disc with an unsupported file system.	It may be possible to play back the disc, but recording is not possible. Exchange the disc for one formatted in a file system supported by this unit. Alternatively, format the disc (see page 39).
File System	on, limit, off	An attempt was made to record to a disc when its file system was set to inhibit recording.	

a) With respect to setting of basic menu item 016

During reception of commands from an external device connected to the REMOTE connector

Message in time data display	Display condition ^{a)}	Description	Action
No Disc!	on	A recording, playback, search, or other command was received with no disc loaded.	Try the operation again after loading a disc.
REC INHI.!	on	A recording or E-E display command was received for a write-protected disc.	Try the operation again after setting the Write Inhibit tab to the recording enabled position.
REC INHI.!	on	A recording or E-E display command was received with extended menu item 310 "REC INHIBIT" set to "on."	Try the operation again after setting extended menu item 310 to "off." <i>See 7-3-2 "Extended Menu Operations" (page 108) about how to make this setting.</i>
IMX50 Clip IMX40 Clip IMX30 Clip DVCAM Clip 4CHx24 Clip 8CHx16 Clip	on, limit	A recording or E-E display command was received with basic menu item for a disc recorded in a format different from the specification of basic menu item 031 "RECORDING FORMAT."	Try the operation again after changing the setting of basic menu item 031. <i>See 7-2-2 "Basic Menu Operations" (page 94) about how to change this setting.</i>

Message in time data display	Display condition ^{a)}	Description	Action
Run Salvage	on, limit	A recording or E-E display command was received for a disc that needs clip recovery (salvage).	Try the operation again after recovering clips from the disc (salvage function). <i>See 3-6-7 "Handling of Discs When Recording Does Not End Normally (Salvage Function)" (page 40).</i>
MAX # Files	on, limit, off	The number of files on the disc had reached the upper limit (5000), or there was not enough capacity in the General directory when a command was received to record, display an E-E picture, record an essence mark, or add a quick scene selection sub clip.	Exchange the disc for one with enough free capacity.
Disc Full!	on, limit, off	A command was received to record or display an E-E picture when there was not enough free capacity on the disc, or when the number of recorded clips had reached the upper limit (300).	
MAX# SB CLP	on, limit, off	A command was received to add a sub clip when the number of registered sub clips had already reached the upper limit (300) of the specifications of this unit.	
CL OVER DUR	on, limit, off	A command was received to add a sub clip when the total duration of sub clips in the clip list had already reached the upper limit (24 hours) of the specifications of this unit.	These operations are not possible.
Disc Damage	on, limit, off	A command was received to record, display an E-E picture, record an essence mark, or add a quick scene selection sub clip when there was no free sparing area.	
Non AV Full	on, limit, off	A command was received to record, display an E-E picture, record an essence mark, or add a quick scene selection sub clip when there was no free Non-Real-Time space.	Insert a different disc with enough free capacity.
No Clip!	on, limit	A playback or search command was received for a disc containing no recorded clips.	These operations are not possible.
Disc Top!	on	A PREV or reverse high-speed search command was received with the disc stopped at the top.	
Disc End!	on	A NEXT or forward high-speed search command was received with the disc stopped at the end.	
TC EXT!	on	A time code or user bits preset command was received with the INT/EXT/RP188 switch is set to EXT and the PRESET/REGEN switch is set to PRESET.	Try the operation again after setting the INT/EXT/RP188 switch to INT and the PRESET/REGEN switch to PRESET. <i>See 7-3-2 "Extended Menu Operations" (page 108) about how to make this setting.</i>
REGEN mode!	on	A time code or user bits preset command was received with the PRESET/REGEN switch is set to REGEN.	

Message in time data display	Display condition ^{a)}	Description	Action
Live Logg!	on, limit	A time code or user bit preset operation was attempted with extended menu item 258 "LIVE LOGGING" set to "on."	Set extended menu item 258 "LIVE LOGGING" to "off" before performing the operation. <i>See 7-3-2 "Extended Menu Operations" (page 108) about how to make this setting.</i>
REC RUN!	on	A time code or user bits preset command was received with the F-RUN/R-RUN switch is set to R-RUN.	Try the operation again after setting the F-RUN/R-RUN switch to F-RUN. <i>See 7-3-2 "Extended Menu Operations" (page 108) about how to make this setting.</i>
REC-PAUSE!	on	A time code or user bits preset command was received with recording paused.	Try the operation again after stopping recording.
REC mode!	on, limit	A command to switch video or audio signals was received during recording.	
REC mode!	on, limit	A command to switch audio channels was received during recording.	

a) With respect to setting of basic menu item 016

During recording and editing operations

Message in time data display	Display condition ^{a)}	Description	Action
Disc Error!	on, limit, off	Normal recording is not possible because of a disc defect.	Use another disc. You can check the state of a disc by checking playback condition marks (see page 36).
525/60 sig!	on, limit	A 525 system SDI signal was input with this unit in 625 line mode (PAL system) and with "SDI" selected with the VIDEO INPUT SEL button.	Input a 625 system SDI signal.
625/50 sig!	on, limit	A 625 system SDI signal was input with this unit in 525(U) or 525(J) line mode (NTSC system) and with "SDI" selected with the VIDEO INPUT SEL button.	Input a 525 system SDI signal.
A mode err!	on, limit	An editing operation was attempted on a recorded disc, when one of the following audio settings differed from the settings of this unit. <ul style="list-style-type: none"> Number of quantizing bits and recording channels Handling of digital audio signals (audio or non-audio) 	To edit this disc, change the following settings. <ul style="list-style-type: none"> Maintenance menu item "AUDIO CONFIG" — "DATA LENGTH" Maintenance menu item "AUDIO CONFIG" — "NON-AUDIO INPUT" <i>See 7-4-2 "Maintenance Menu Operations" (page 114) about how to make these settings.</i>
ILL. REF!	on, limit, off	The playback system and recording system are not synchronized.	Input a reference video signal to the player and recorder.
ILL. REC!	on, limit	A sync error between encoder and input signal occurred during recording.	Contact your Sony service representative.
ILL. PLAY!	on, limit	An audio/video phase error occurred during playback.	
MEM. Full!	on, limit	A memory write error occurred.	
MEM. Empty	on, limit	Playback data in memory was lost, and playback stopped.	

Message in time data display	Display condition ^{a)}	Description	Action
List Exists	on, limit, off	An attempt was made to edit a clip referenced by sub clips.	Delete all clip lists. <i>See 5-3-2 "Deleting Clip Lists From a Disc" (page 69).</i>
Clip End!	on, limit, off	An attempt was made to edit across clip boundaries.	Editing across multiple clips is not possible.
Recording	on, limit	More time than normal is required for recording processing, because recording is being done while avoiding defects on the disc.	Wait until recording finishes.

a) With respect to setting of basic menu item 016

Alarms relating to audio and video signals

Message in time data display	Display condition ^{a)}	Description	Action
REF NON-STD	on, limit, off	A signal other than a standard reference video signal was input to the REF VIDEO IN connector.	Input a standard reference video signal to the REF VIDEO IN connector.
No INPUT!	on	An attempt to record was made with no input video signal.	Input a video signal, and select it.
VIN NON-STD	on	Recording is being done with a signal other than a standard video signal input to the VIDEO IN connector.	Input a standard video signal to the VIDEO IN connector.
EMPHASIS!	on	An unsupported audio emphasis signal ("EMPHASIS ON" signal) was input.	This unit does not support "EMPHASIS ON" audio signals. Input "EMPHASIS OFF" signal.

a) With respect to setting of basic menu item 016

Alarms relating to sensors and drives

Message in time data display	Display condition ^{a)}	Description	Action
HUMID!	on, limit, off	Condensation was detected in the unit.	<i>See 8-2 "Condensation" (page 121).</i>
FAN Stopped	on, limit, off	The motor of the main unit fan has stopped.	Contact your Sony service representative.
DR-FAN Stop	on, limit, off	The motor of a drive fan has stopped.	Note The unit will operate, but continued use in this state will result in rising temperatures in the unit or drive, with the risk of fire or damage to the unit.
High TEMP!	on, limit, off	Temperatures have risen within the unit.	
High TEMP!	on, limit, off	Temperatures have risen within a drive.	

a) With respect to setting of basic menu item 016

Appendixes

Specifications

General

Power requirements

100 V to 240 V AC, 50/60 Hz
DC, battery

Power consumption

AC: 37W
DC or battery: 31W

Peak inrush current

- (1) Power ON, current probe method: 65 A (240 V), 30 A (100 V)
- (2) Hot switching inrush current, measured in accordance with European standard EN55103-1: 35 A (230 V)

Operating temperature

0°C to 40°C (32°F to 104°F)

Storage temperature

-20°C to +60°C (-4°F to +140°F)

Operating relative humidity

20% to 90%

Mass

4.7 kg (10 lb 5 oz)

External dimensions (w/h/d, excluding projections)

230 × 105 × 340mm
(9¹/₈ × 4¹/₄ × 13¹/₂ inches)

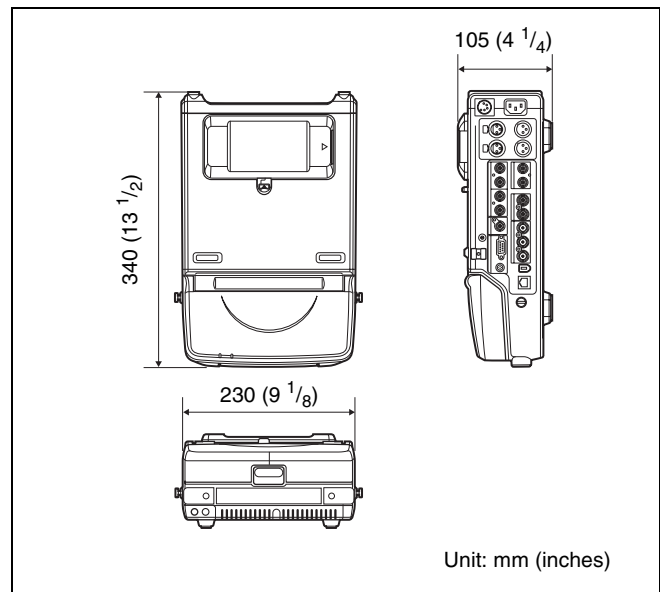

System

Recording/Playback format

Video MPEG IMX (50/40/30 Mbps), DVCAM (25 Mbps)

Proxy video

MPEG-4 ¹⁾

Audio MPEG IMX: 16 bits/48 kHz (8 channels)
or 24 bits/48 kHz (4 channels)
DVCAM: 16 bits/48 kHz (4 channels)

Proxy audio

A-law (8/4 channels, 8 bits, 8 kHz)

1) The MPEG-4 Codec is a product of Ingenient Technologies, Inc.

Recording/Playback time

MPEG IMX

50 Mbps: 45 min.

40 Mbps: 55 min.

30 Mbps: 68 min.

DVCAM 85 min.

Search speed

Jog mode

±1 times normal speed
Shuttle mode
±20 times normal speed

Video performance

Sampling frequency
Y: 13.5 MHz, R-Y/B-Y: 6.75 MHz
Quantization 10 bits/sample
Analog composite input to analog composite output
Bandwidth: 30 Hz to 4.5 MHz +0.5/-1.5 dB (NTSC), 25 Hz to 5.5 MHz +0.5/-1.5 dB (PAL)
S/N ratio: 53 dB or more
Differential gain: 2% or less
Differential phase: 2° or less
Y/C delay: 20 ns or less
K-factor (2T pulse): 2% or less

Processor adjustment range

Video level -∞ to +3 dB
Chroma level -∞ to +3 dB
Set up/black level
±30 IRE/±210 mV
Chroma phase/hue
±30°
System sync phase
±3 μs
System SC phase
±200 ns

Audio performance

Frequency response
20 Hz to 20 kHz +0.5/-1.0 dB (0 dB at 1 kHz)
Dynamic range More than 90 dB
Distortion Less than 0.05% (at 1kHz)
Head room 20/18/16/12 dB (Selectable with menu)

Input connectors

Digital signal inputs

SDI IN BNC type (×1)
SDI format (270 Mbps), SMPTE 259M/CCIR656-III
DIGITAL AUDIO (AES/EBU) IN 1/2, 3/4
BNC type (×2), complying with AES-3id-1995
 S400 (i.LINK)
6-pin (×1), complying with IEEE 1394

Analog video inputs

REF VIDEO IN
BNC type (×1)

Black burst
0.286 V (NTSC), 0.3V (PAL), 75 Ω,
negative sync
Composite sync
VIDEO IN BNC type (×1), composite
1.0 Vp-p, 75 Ω, negative sync

Analog audio inputs

AUDIO IN 1/3, 2/4
XLR 3-pin, female (×2), +4/0/-3/-6 dBu
(selectable with menu), 10 kΩ,
balanced

Time code input

TC IN BNC type (×1), SMPTE time code, 0.5
Vp-p to 18 Vp-p, 3.3 kΩ, unbalanced

(network)

100Base-TX/10Base-T
RJ-45 type (×1)
100BASE-TX: complying with IEEE
802.3u
10BASE-T: complying with IEEE 802.3

Output connectors

Digital signal outputs

SDI OUT (SUPER)
BNC type (×1)
SDI format (270 Mbps), SMPTE 259M/
CCIR656-III
DIGITAL AUDIO (AES/EBU) OUT 1/2, 3/4
BNC type (×2), complying with AES-
3id-1995
 S400 (i.LINK)
6-pin (×1), complying with IEEE 1394

Analog video outputs

VIDEO OUT 1, 2(SUPER)
BNC type (×2), composite, 1.0 Vp-p,
75 Ω, sync negative

Analog audio outputs

AUDIO OUT 1/3, 2/4
XLR 3-pin, male (×2), +4/0/-3/-6 dBu
(selectable with menu), 600 Ω loading,
low impedance, balanced

Output for headphones

PHONES JM-60 Stereo phone jack (×1), -∞ to -13
dBu, 8 Ω, unbalanced

Time code output

TC OUT BNC type (×1), SMPTE time code, 2.2
Vp-p ±3 dB, 600 Ω, unbalanced

Remote control connectors

REMOTE D-sub 9-pin (×1), for connection of
editing control unit, RS-422A standard

i.S400 (i.LINK)
6-pin (×1), complying with IEEE 1394,
supporting file access mode

Power input/output connectors

DC IN 12V XLR 4-pin, male (×1), 11 to 17 V DC
DC OUT 12V ¹⁾
Round type 4-pin, female (×1)
When driven by AC power: DC 14.5 V,
Max. 5W
When driven by DC power or battery: DC
11 to 17 V, Max. 5W

1) Use as power source for BVR-3 Remote Control Unit (not supplied) and
RM-280 Editing Controller (not supplied).

Others

Video panel Picture: 3.5 type
Pixel resolution: 211,200 pixels (960
wide × 220 high)
Effective picture elements: more than
99.99%

Accessories supplied

Operation manuals
English version (1)
Japanese version (1)
CD-ROM manual (1)
PDZ-1 Proxy Browsing Software (1)
Connector caps For ~AC IN/DC IN 12V connector (1)
For AUDIO IN connectors (2)
For AUDIO OUT connectors (2)
For BNC connectors (12)
For S400 (i.LINK) connector (1)
For REMOTE connector (1)
For DC OUT 12V connector (1)

Accessories not supplied

AC power cord
• For the customers in the U.S.A and Canada
Part No. 1-551-812-41 (125 V, 10 A, about 2.4 m)
• For the customers in the United Kingdom
Part No. 1-777-823-12 (250 V, 10 A, about 2.0 m)
• For the customers in European countries other than the
United Kingdom
Part No. 1-551-631-61 (250 V, 10 A, about 2.0 m)
Shoulder strap (Part No. A-6772-374-C)

Related products

Battery packs
BP-GL95, BP-GL65, BP-L80S, BP-
L60S
RM-280 editing controller

Design and specifications are subject to change without
notice.

Notes

- Always make a test recording, and verify that it was recorded successfully.
SONY WILL NOT BE LIABLE FOR DAMAGES OF ANY KIND INCLUDING, BUT NOT LIMITED TO, COMPENSATION OR REIMBURSEMENT ON ACCOUNT OF FAILURE OF THIS UNIT OR ITS RECORDING MEDIA, EXTERNAL STORAGE SYSTEMS OR ANY OTHER MEDIA OR STORAGE SYSTEMS TO RECORD CONTENT OF ANY TYPE.
- Always verify that the unit is operating properly before use. SONY WILL NOT BE LIABLE FOR DAMAGES OF ANY KIND INCLUDING, BUT NOT LIMITED TO, COMPENSATION OR REIMBURSEMENT ON ACCOUNT OF THE LOSS OF PRESENT OR PROSPECTIVE PROFITS DUE TO FAILURE OF THIS UNIT, EITHER DURING THE WARRANTY PERIOD OR AFTER EXPIRATION OF THE WARRANTY, OR FOR ANY OTHER REASON WHATSOEVER.

Using the Shoulder Belt

The following figures show how to fit the shoulder belt (not supplied).

Caution

If you fit the shoulder belt incorrectly, the unit may fall down and cause body injury. Follow the procedures described below to fit or remove the shoulder belt.

To fit the shoulder belt

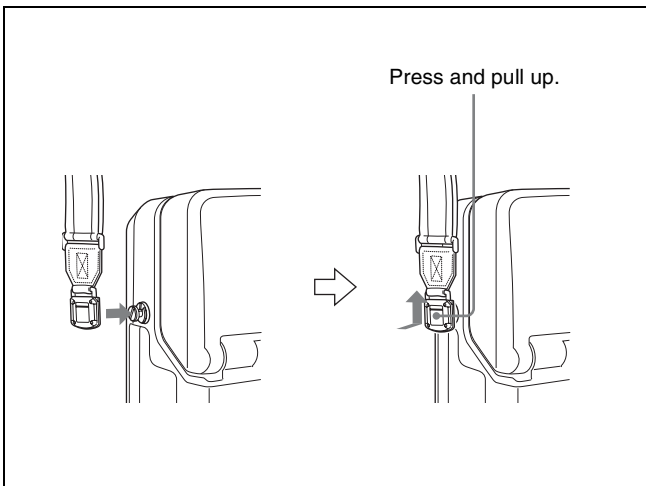

To remove the shoulder belt

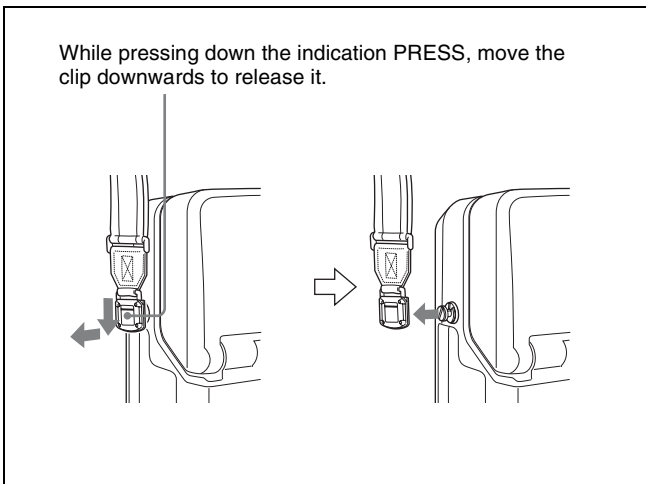

Notice Concerning the Software License of This Unit

Thank you for your purchasing this Sony product. Please read the following notice before using the product. By installing, copying or otherwise using the product, you will be deemed to have understood and agreed to the content of the notice.

Notice Concerning Software Governed by the GNU GPL/LGPL

This product includes software to which the GNU General Public License (“GPL”) or GNU Lesser General Public License (“LGPL”) applies. Under the terms of the GPL/LGPL, of which a copy is attached, you have the right to obtain, modify, and distribute copies of the source code of this software.

Specific instructions for downloading the source code can be found at the following URL:

<http://www.sony.net/Products/Linux/>

Please note that we cannot respond to inquiries regarding the content of the source code.

GNU GENERAL PUBLIC LICENSE

Version 2, June 1991

Copyright © 1989, 1991 Free Software Foundation, Inc.
59 Temple Place, Suite 330, Boston, MA 02111-1307 USA

Everyone is permitted to copy and distribute verbatim copies of this license document, but changing it is not allowed.

Preamble

The licenses for most software are designed to take away your freedom to share and change it. By contrast, the GNU General Public License is intended to guarantee your freedom to share and change free software—to make sure the software is free for all its users. This General Public License applies to most of the Free Software Foundation’s software and to any other program whose authors commit to using it. (Some other Free Software Foundation software is covered by the GNU Library General Public License instead.) You can apply it to your programs, too.

When we speak of free software, we are referring to freedom, not price. Our General Public Licenses are designed to make sure that you have the freedom to distribute copies of free software (and charge for this service if you wish), that you receive source code or can get it if you want it, that you can change the software or use pieces of it in new free programs; and that you know you can do these things.

To protect your rights, we need to make restrictions that forbid anyone to deny you these rights or to ask you to surrender the rights.

These restrictions translate to certain responsibilities for you if you distribute copies of the software, or if you modify it.

For example, if you distribute copies of such a program, whether gratis or for a fee, you must give the recipients all the rights that you have. You must make sure that they, too, receive or can get the source code. And you must show them these terms so they know their rights.

We protect your rights with two steps: (1) copyright the software, and (2) offer you this license which gives you legal permission to copy, distribute and/or modify the software.

Also, for each author’s protection and ours, we want to make certain that everyone understands that there is no warranty for this free software. If the software is modified by someone else and passed on, we want its recipients to know that what they have is not the original, so that any problems introduced by others will not reflect on the original authors’ reputations.

Finally, any free program is threatened constantly by software patents. We wish to avoid the danger that redistributors of a free program will individually obtain patent licenses, in effect making the program proprietary. To prevent this, we have made it clear that any patent must be licensed for everyone’s free use or not licensed at all.

The precise terms and conditions for copying, distribution and modification follow.

GNU GENERAL PUBLIC LICENSE TERMS AND CONDITIONS FOR COPYING, DISTRIBUTION AND MODIFICATION

0. This License applies to any program or other work which contains a notice placed by the copyright holder saying it may be distributed under the terms of this General Public License. The “Program”, below, refers to any such program or work, and a “work based on the Program” means either the Program or any derivative work under copyright law: that is to say, a work containing the Program or a portion of it, either verbatim or with modifications and/or translated into another language. (Hereinafter, translation is included without limitation in the term “modification”.) Each licensee is addressed as “you”.

Activities other than copying, distribution and modification are not covered by this License; they are outside its scope. The act of running the Program is not restricted, and the output from the Program is covered only if its contents constitute a work based on the Program (independent of having been made by running the Program). Whether that is true depends on what the Program does.

1. You may copy and distribute verbatim copies of the Program’s source code as you receive it, in any medium, provided that you conspicuously and appropriately publish on each copy an appropriate copyright notice and disclaimer of warranty; keep intact all the notices that refer to this License and to the absence of any warranty; and give any other recipients of the Program a copy of this License along with the Program.

You may charge a fee for the physical act of transferring a copy, and you may at your option offer warranty protection in exchange for a fee.

2. You may modify your copy or copies of the Program or any portion of it, thus forming a work based on the Program, and copy and distribute such modifications or work under the terms of Section 1 above, provided that you also meet all of these conditions:

- a) You must cause the modified files to carry prominent notices stating that you changed the files and the date of any change.
- b) You must cause any work that you distribute or publish, that in whole or in part contains or is derived from the Program or any part thereof, to be licensed as a whole at no charge to all third parties under the terms of this License.
- c) If the modified program normally reads commands interactively when run, you must cause it, when started running for such interactive use in the most ordinary way, to print or display an announcement including an appropriate copyright notice and a notice that there is no warranty (or else, saying that you provide a warranty) and that users may redistribute the program under these conditions, and telling the user how to view a copy of this License. (Exception: if the Program itself is interactive but does not normally print such an announcement, your work based on the Program is not required to print an announcement.)

These requirements apply to the modified work as a whole. If identifiable sections of that work are not derived from the Program, and can be reasonably considered independent and separate works in themselves, then this License, and its terms, do not apply to those sections when you distribute them as separate works. But when you distribute the same sections as part of a whole which is a work based on the Program, the distribution of the whole must be on the terms of this License, whose permissions for other licensees extend to the entire whole, and thus to each and every part regardless of who wrote it.

Thus, it is not the intent of this section to claim rights or contest your rights to work written entirely by you; rather, the intent is to exercise the right to control the distribution of derivative or collective works based on the Program.

In addition, mere aggregation of another work not based on the Program with the Program (or with a work based on the Program) on a volume of a storage or distribution medium does not bring the other work under the scope of this License.

3. You may copy and distribute the Program (or a work based on it, under Section 2) in object code or executable form under the terms of Sections 1 and 2 above provided that you also do one of the following:

- a) Accompany it with the complete corresponding machine-readable source code, which must be distributed under the terms of Sections 1 and 2 above on a medium customarily used for software interchange; or,
- b) Accompany it with a written offer, valid for at least three years, to give any third party, for a charge no more than your cost of physically performing source distribution, a complete machine-readable copy of the corresponding source code, to be distributed under the terms of Sections 1 and 2 above on a medium customarily used for software interchange; or,
- c) Accompany it with the information you received as to the offer to distribute corresponding source code. (This alternative is allowed only for noncommercial distribution and only if you received the program in object code or executable form with such an offer, in accord with Subsection b above.)

The source code for a work means the preferred form of the work for making modifications to it. For an executable work, complete source code means all the source code for all modules it contains, plus any associated interface definition files, plus the scripts used to control compilation and installation of the executable. However, as a special exception, the source code distributed need not include anything that is normally distributed (in either source or binary form) with the major components (compiler, kernel, and so on) of the operating system on which the executable runs, unless that component itself accompanies the executable.

If distribution of executable or object code is made by offering access to copy from a designated place, then offering equivalent access to copy the source code from the same place counts as distribution of the source code, even though third parties are not compelled to copy the source along with the object code.

- 4. You may not copy, modify, sublicense, or distribute the Program except as expressly provided under this License. Any attempt otherwise to copy, modify, sublicense or distribute the Program is void, and will automatically terminate your rights under this License.
However, parties who have received copies, or rights, from you under this License will not have their licenses terminated so long as such parties remain in full compliance.
- 5. You are not required to accept this License, since you have not signed it. However, nothing else grants you permission to modify or distribute the Program or its derivative works. These actions are prohibited by law if you do not accept this License. Therefore, by modifying or distributing the Program (or any work based on the Program), you indicate your acceptance of this License to do so, and all its terms and conditions for copying, distributing or modifying the Program or works based on it.
- 6. Each time you redistribute the Program (or any work based on the Program), the recipient automatically receives a license from the original licensor to copy, distribute or modify the Program subject to these terms and conditions. You may not impose any further restrictions on the recipients' exercise of the rights granted herein.
You are not responsible for enforcing compliance by third parties to this License.
- 7. If, as a consequence of a court judgment or allegation of patent infringement or for any other reason (not limited to patent issues), conditions are imposed on you (whether by court order, agreement or otherwise) that contradict the conditions of this License, they do not excuse you from the conditions of this License. If you cannot distribute so as to satisfy simultaneously your obligations under this License and any other pertinent obligations, then as a consequence you may not distribute the Program at all. For example, if a patent license would not permit royalty-free redistribution of the Program by all those who receive copies directly or indirectly through you, then the only way you could satisfy both it and this License would be to refrain entirely from distribution of the Program.

If any portion of this section is held invalid or unenforceable under any particular circumstance, the balance of the section is intended to apply and the section as a whole is intended to apply in other circumstances.

It is not the purpose of this section to induce you to infringe any patents or other property right claims or to contest validity of any such claims; this section has the sole purpose of protecting the integrity of the free software distribution system, which is implemented by public license practices. Many people have made generous contributions to the wide range of software distributed through that system in reliance on consistent application of that system; it is up to the author/donor to decide if he or she is willing to distribute software through any other system and a licensee cannot impose that choice.

This section is intended to make thoroughly clear what is believed to be a consequence of the rest of this License.

8. If the distribution and/or use of the Program is restricted in certain countries either by patents or by copyrighted interfaces, the original copyright holder who places the Program under this License may add an explicit geographical distribution limitation excluding those countries, so that distribution is permitted only in or among countries not thus excluded. In such case, this License incorporates the limitation as if written in the body of this License.
9. The Free Software Foundation may publish revised and/or new versions of the General Public License from time to time. Such new versions will be similar in spirit to the present version, but may differ in detail to address new problems or concerns.

Each version is given a distinguishing version number. If the Program specifies a version number of this License which applies to it and “any later version”, you have the option of following the terms and conditions either of that version or of any later version published by the Free Software Foundation. If the Program does not specify a version number of this License, you may choose any version ever published by the Free Software Foundation.

10. If you wish to incorporate parts of the Program into other free programs whose distribution conditions are different, write to the author to ask for permission. For software which is copyrighted by the Free Software Foundation, write to the Free Software Foundation; we sometimes make exceptions for this. Our decision will be guided by the two goals of preserving the free status of all derivatives of our free software and of promoting the sharing and reuse of software generally.

NO WARRANTY

11. BECAUSE THE PROGRAM IS LICENSED FREE OF CHARGE, THERE IS NO WARRANTY FOR THE PROGRAM, TO THE EXTENT PERMITTED BY APPLICABLE LAW. EXCEPT WHEN OTHERWISE STATED IN WRITING THE COPYRIGHT HOLDERS AND/OR OTHER PARTIES PROVIDE THE PROGRAM “AS IS” WITHOUT WARRANTY OF ANY KIND, EITHER EXPRESSED OR IMPLIED, INCLUDING, BUT NOT LIMITED TO, THE IMPLIED WARRANTIES OF MERCHANTABILITY AND FITNESS FOR A PARTICULAR PURPOSE. THE ENTIRE RISK AS TO THE QUALITY AND PERFORMANCE OF THE PROGRAM IS WITH YOU. SHOULD THE PROGRAM PROVE DEFECTIVE, YOU ASSUME THE COST OF ALL NECESSARY SERVICING, REPAIR OR CORRECTION.
12. IN NO EVENT UNLESS REQUIRED BY APPLICABLE LAW OR AGREED TO IN WRITING WILL ANY COPYRIGHT HOLDER, OR ANY OTHER PARTY WHO MAY MODIFY AND/OR REDISTRIBUTE THE PROGRAM AS PERMITTED ABOVE, BE LIABLE TO YOU FOR DAMAGES, INCLUDING ANY GENERAL, SPECIAL, INCIDENTAL OR CONSEQUENTIAL DAMAGES ARISING OUT OF THE USE OR INABILITY TO USE THE PROGRAM (INCLUDING BUT NOT LIMITED TO LOSS OF DATA OR DATA BEING RENDERED INACCURATE OR LOSSES SUSTAINED BY YOU OR THIRD PARTIES OR A FAILURE OF THE PROGRAM TO OPERATE WITH ANY OTHER PROGRAMS), EVEN IF SUCH HOLDER OR OTHER PARTY HAS BEEN ADVISED OF THE POSSIBILITY OF SUCH DAMAGES.

END OF TERMS AND CONDITIONS

How to Apply These Terms to Your New Programs

If you develop a new program, and you want it to be of the greatest possible use to the public, the best way to achieve this is to make it free software which everyone can redistribute and change under these terms.

To do so, attach the following notices to the program. It is safest to attach them to the start of each source file to most effectively convey the exclusion of warranty; and each file should have at least the “copyright” line and a pointer to where the full notice is found.

Copyright ©

This program is free software; you can redistribute it and/or modify it under the terms of the GNU General Public License as published by the Free Software Foundation; either version 2 of the License, or (at your option) any later version.

This program is distributed in the hope that it will be useful, but WITHOUT ANY WARRANTY; without even the implied warranty of MERCHANTABILITY or FITNESS FOR A PARTICULAR PURPOSE. See the GNU General Public License for more details.

You should have received a copy of the GNU General Public License along with this program; if not, write to the Free Software Foundation, Inc., 59 Temple Place, Suite 330, Boston, MA 02111-1307 USA

Also add information on how to contact you by electronic and paper mail.

If the program is interactive, make it output a short notice like this when it starts in an interactive mode:
Gnomovision version 69, Copyright © year name of author Gnomovision comes with ABSOLUTELY NO WARRANTY;
for details type 'show w'.

This is free software, and you are welcome to redistribute it under certain conditions; type 'show c' for details.

The hypothetical commands 'show w' and 'show c' should show the appropriate parts of the General Public License. Of course, the commands you use may be called something other than 'show w' and 'show c', they could even be mouse-clicks or menu items-whatever suits your program.

You should also get your employer (if you work as a programmer) or your school, if any, to sign a "copyright disclaimer" for the program, if necessary. Here is a sample; alter the names:

Yoyodyne, Inc., hereby disclaims all copyright interest in the program 'Gnomovision' (which makes passes at compilers) written by James Hacker.

, 1 April 1989

Ty Coon, President of Vice

This General Public License does not permit incorporating your program into proprietary programs. If your program is a subroutine library, you may consider it more useful to permit linking proprietary applications with the library. If this is what you want to do, use the GNU Library General Public License instead of this License.

GNU LESSER GENERAL PUBLIC LICENSE

Version 2.1, February 1999

Copyright © 1991, 1999 Free Software Foundation, Inc.

59 Temple Place, Suite 330, Boston, MA 02111-1307 USA

Everyone is permitted to copy and distribute verbatim copies of this license document, but changing it is not allowed.

[This is the first released version of the Lesser GPL. It also counts as the successor of the GNU Library Public License, version 2, hence the version number 2.1.]

Preamble

The licenses for most software are designed to take away your freedom to share and change it. By contrast, the GNU General Public Licenses are intended to guarantee your freedom to share and change free software-to make sure the software is free for all its users.

This license, the Lesser General Public License, applies to some specially designated software packages-typically libraries-of the Free Software Foundation and other authors who decide to use it. You can use it too, but we suggest you first think carefully about whether this license or the ordinary General Public License is the better strategy to use in any particular case, based on the explanations below.

When we speak of free software, we are referring to freedom of use, not price. Our General Public Licenses are designed to make sure that you have the freedom to distribute copies of free software (and charge for this service if you wish); that you receive source code or can get it if you want it; that you can change the software and use pieces of it in new free programs; and that you are informed that you can do these things.

To protect your rights, we need to make restrictions that forbid distributors to deny you these rights or to ask you to surrender these rights. These restrictions translate to certain responsibilities for you if you distribute copies of the library or if you modify it.

For example, if you distribute copies of the library, whether gratis or for a fee, you must give the recipients all the rights that we gave you. You must make sure that they, too, receive or can get the source code. If you link other code with the library, you must provide complete object files to the recipients, so that they can relink them with the library after making changes to the library and recompiling it. And you must show them these terms so they know their rights.

We protect your rights with a two-step method: (1) we copyright the library, and (2) we offer you this license, which gives you legal permission to copy, distribute and/or modify the library.

To protect each distributor, we want to make it very clear that there is no warranty for the free library. Also, if the library is modified by someone else and passed on, the recipients should know that what they have is not the original version, so that the original author's reputation will not be affected by problems that might be introduced by others.

Finally, software patents pose a constant threat to the existence of any free program. We wish to make sure that a company cannot effectively restrict the users of a free program by obtaining a restrictive license from a patent holder. Therefore, we insist that any patent license obtained for a version of the library must be consistent with the full freedom of use specified in this license.

Most GNU software, including some libraries, is covered by the ordinary GNU General Public License. This license, the GNU Lesser General Public License, applies to certain designated libraries, and is quite different from the ordinary General Public License. We use this license for certain libraries in order to permit linking those libraries into non-free programs.

When a program is linked with a library, whether statically or using a shared library, the combination of the two is legally speaking a combined work, a derivative of the original library. The ordinary General Public License therefore permits such linking only if the entire combination fits its criteria of freedom. The Lesser General Public License permits more lax criteria for linking other code with the library.

We call this license the “Lesser” General Public License because it does Less to protect the user's freedom than the ordinary General Public License. It also provides other free software developers Less of an advantage over competing non-free programs. These disadvantages are the reason we use the ordinary General Public License for many libraries. However, the Lesser license provides advantages in certain special circumstances.

For example, on rare occasions, there may be a special need to encourage the widest possible use of a certain library, so that it becomes a de-facto standard. To achieve this, non-free programs must be allowed to use the library. A more frequent case is that a free library does the same job as widely used non-free libraries. In this case, there is little to gain by limiting the free library to free software only, so we use the Lesser General Public License.

In other cases, permission to use a particular library in non-free programs enables a greater number of people to use a large body of free software. For example, permission to use the GNU C Library in non-free programs enables many more people to use the whole GNU operating system, as well as its variant, the GNU/Linux operating system.

Although the Lesser General Public License is Less protective of the users' freedom, it does ensure that the user of a program that is linked with the Library has the freedom and the wherewithal to run that program using a modified version of the Library. The precise terms and conditions for copying, distribution and modification follow. Pay close attention to the difference between a “work based on the library” and a “work that uses the library”. The former contains code derived from the library, whereas the latter must be combined with the library in order to run.

GNU LESSER GENERAL PUBLIC LICENSE TERMS AND CONDITIONS FOR COPYING, DISTRIBUTION AND MODIFICATION

0. This License Agreement applies to any software library or other program which contains a notice placed by the copyright holder or other authorized party saying it may be distributed under the terms of this Lesser General Public License (also called “this License”). Each licensee is addressed as “you”.

A “library” means a collection of software functions and/or data prepared so as to be conveniently linked with application programs (which use some of those functions and data) to form executables.

The “Library”, below, refers to any such software library or work which has been distributed under these terms. A “work based on the Library” means either the Library or any derivative work under copyright law: that is to say, a work containing the Library or a portion of it, either verbatim or with modifications and/or translated straightforwardly into another language. (Hereinafter, translation is included without limitation in the term “modification”.)

“Source code” for a work means the preferred form of the work for making modifications to it. For a library, complete source code means all the source code for all modules it contains, plus any associated interface definition files, plus the scripts used to control compilation and installation of the library.

Activities other than copying, distribution and modification are not covered by this License; they are outside its scope. The act of running a program using the Library is not restricted, and output from such a program is covered only if its contents constitute a work based on the Library (independent of the use of the Library in a tool for writing it). Whether that is true depends on what the Library does and what the program that uses the Library does.

1. You may copy and distribute verbatim copies of the Library’s complete source code as you receive it, in any medium, provided that you conspicuously and appropriately publish on each copy an appropriate copyright notice and disclaimer of warranty; keep intact all the notices that refer to this License and to the absence of any warranty; and distribute a copy of this License along with the Library.

You may charge a fee for the physical act of transferring a copy, and you may at your option offer warranty protection in exchange for a fee.

2. You may modify your copy or copies of the Library or any portion of it, thus forming a work based on the Library, and copy and distribute such modifications or work under the terms of Section 1 above, provided that you also meet all of these conditions:

- a) The modified work must itself be a software library.
- b) You must cause the files modified to carry prominent notices stating that you changed the files and the date of any change.
- c) You must cause the whole of the work to be licensed at no charge to all third parties under the terms of this License.
- d) If a facility in the modified Library refers to a function or a table of data to be supplied by an application program that uses the facility, other than as an argument passed when the facility is invoked, then you must make a good faith effort to ensure that, in the event an application does not supply such function or table, the facility still operates, and performs whatever part of its purpose remains meaningful.

(For example, a function in a library to compute square roots has a purpose that is entirely well-defined independent of the application. Therefore, Subsection 2d requires that any application-supplied function or table used by this function must be optional: if the application does not supply it, the square root function must still compute square roots.)

These requirements apply to the modified work as a whole. If identifiable sections of that work are not derived from the Library, and can be reasonably considered independent and separate works in themselves, then this License, and its terms, do not apply to those sections when you distribute them as separate works. But when you distribute the same sections as part of a whole which is a work based on the Library, the distribution of the whole must be on the terms of this License, whose permissions for other licensees extend to the entire whole, and thus to each and every part regardless of who wrote it.

Thus, it is not the intent of this section to claim rights or contest your rights to work written entirely by you; rather, the intent is to exercise the right to control the distribution of derivative or collective works based on the Library.

In addition, mere aggregation of another work not based on the Library with the Library (or with a work based on the Library) on a volume of a storage or distribution medium does not bring the other work under the scope of this License.

3. You may opt to apply the terms of the ordinary GNU General Public License instead of this License to a given copy of the Library. To do this, you must alter all the notices that refer to this License, so that they refer to the ordinary GNU General Public License, version 2, instead of to this License. (If a newer version than version 2 of the ordinary GNU General Public License has appeared, then you can specify that version instead if you wish.) Do not make any other change in these notices.

Once this change is made in a given copy, it is irreversible for that copy, so the ordinary GNU General Public License applies to all subsequent copies and derivative works made from that copy.

This option is useful when you wish to copy part of the code of the Library into a program that is not a library.

4. You may copy and distribute the Library (or a portion or derivative of it, under Section 2) in object code or executable form under the terms of Sections 1 and 2 above provided that you accompany it with the complete corresponding machine-readable source code, which must be distributed under the terms of Sections 1 and 2 above on a medium customarily used for software interchange.

If distribution of object code is made by offering access to copy from a designated place, then offering equivalent access to copy the source code from the same place satisfies the requirement to distribute the source code, even though third parties are not compelled to copy the source along with the object code.

5. A program that contains no derivative of any portion of the Library, but is designed to work with the Library by being compiled or linked with it, is called a “work that uses the Library”. Such a work, in isolation, is not a derivative work of the Library, and therefore falls outside the scope of this License.

However, linking a “work that uses the Library” with the Library creates an executable that is a derivative of the Library (because it contains portions of the Library), rather than a “work that uses the library”. The executable is therefore covered by this License. Section 6 states terms for distribution of such executables.

When a “work that uses the Library” uses material from a header file that is part of the Library, the object code for the work may be a derivative work of the Library even though the source code is not. Whether this is true is especially significant if the work can be linked without the Library, or if the work is itself a library. The threshold for this to be true is not precisely defined by law.

If such an object file uses only numerical parameters, data structure layouts and accessors, and small macros and small inline functions (ten lines or less in length), then the use of the object file is unrestricted, regardless of whether it is legally a derivative work. (Executables containing this object code plus portions of the Library will still fall under Section 6.)

Otherwise, if the work is a derivative of the Library, you may distribute the object code for the work under the terms of Section 6. Any executables containing that work also fall under Section 6, whether or not they are linked directly with the Library itself.

6. As an exception to the Sections above, you may also combine or link a “work that uses the Library” with the Library to produce a work containing portions of the Library, and distribute that work under terms of your choice, provided that the terms permit modification of the work for the customer’s own use and reverse engineering for debugging such modifications.

You must give prominent notice with each copy of the work that the Library is used in it and that the Library and its use are covered by this License. You must supply a copy of this License. If the work during execution displays copyright notices, you must include the copyright notice for the Library among them, as well as a reference directing the user to the copy of this License. Also, you must do one of these things:

- a) Accompany the work with the complete corresponding machine-readable source code for the Library including whatever changes were used in the work (which must be distributed under Sections 1 and 2 above); and, if the work is an executable linked with the Library, with the complete machine-readable “work that uses the Library”, as object code and/or source code, so that the user can modify the Library and then relink to produce a modified executable

containing the modified Library. (It is understood that the user who changes the contents of definitions files in the Library will not necessarily be able to recompile the application to use the modified definitions.)

- b) Use a suitable shared library mechanism for linking with the Library. A suitable mechanism is one that (1) uses at run time a copy of the library already present on the user's computer system, rather than copying library functions into the executable, and (2) will operate properly with a modified version of the library, if the user installs one, as long as the modified version is interface-compatible with the version that the work was made with.
- c) Accompany the work with a written offer, valid for at least three years, to give the same user the materials specified in Subsection 6a, above, for a charge no more than the cost of performing this distribution.
- d) If distribution of the work is made by offering access to copy from a designated place, offer equivalent access to copy the above specified materials from the same place.
- e) Verify that the user has already received a copy of these materials or that you have already sent this user a copy.

For an executable, the required form of the "work that uses the Library" must include any data and utility programs needed for reproducing the executable from it. However, as a special exception, the materials to be distributed need not include anything that is normally distributed (in either source or binary form) with the major components (compiler, kernel, and so on) of the operating system on which the executable runs, unless that component itself accompanies the executable.

It may happen that this requirement contradicts the license restrictions of other proprietary libraries that do not normally accompany the operating system. Such a contradiction means you cannot use both them and the Library together in an executable that you distribute.

- 7. You may place library facilities that are a work based on the Library side-by-side in a single library together with other library facilities not covered by this License, and distribute such a combined library, provided that the separate distribution of the work based on the Library and of the other library facilities is otherwise permitted, and provided that you do these two things:
 - a) Accompany the combined library with a copy of the same work based on the Library, uncombined with any other library facilities. This must be distributed under the terms of the Sections above.
 - b) Give prominent notice with the combined library of the fact that part of it is a work based on the Library, and explaining where to find the accompanying uncombined form of the same work.
- 8. You may not copy, modify, sublicense, link with, or distribute the Library except as expressly provided under this License. Any attempt otherwise to copy, modify, sublicense, link with, or distribute the Library is void, and will automatically terminate your rights under this License. However, parties who have received copies, or rights, from you under this License will not have their licenses terminated so long as such parties remain in full compliance.
- 9. You are not required to accept this License, since you have not signed it. However, nothing else grants you permission to modify or distribute the Library or its derivative works. These actions are prohibited by law if you do not accept this License. Therefore, by modifying or distributing the Library (or any work based on the Library), you indicate your acceptance of this License to do so, and all its terms and conditions for copying, distributing or modifying the Library or works based on it.
- 10. Each time you redistribute the Library (or any work based on the Library), the recipient automatically receives a license from the original licensor to copy, distribute, link with or modify the Library subject to these terms and conditions. You may not impose any further restrictions on the recipients' exercise of the rights granted herein. You are not responsible for enforcing compliance by third parties with this License.
- 11. If, as a consequence of a court judgment or allegation of patent infringement or for any other reason (not limited to patent issues), conditions are imposed on you (whether by court order, agreement or otherwise) that contradict the conditions of this License, they do not excuse you from the conditions of this License. If you cannot distribute so as

to satisfy simultaneously your obligations under this License and any other pertinent obligations, then as a consequence you may not distribute the Library at all. For example, if a patent license would not permit royalty-free redistribution of the Library by all those who receive copies directly or indirectly through you, then the only way you could satisfy both it and this License would be to refrain entirely from distribution of the Library.

If any portion of this section is held invalid or unenforceable under any particular circumstance, the balance of the section is intended to apply, and the section as a whole is intended to apply in other circumstances.

It is not the purpose of this section to induce you to infringe any patents or other property right claims or to contest validity of any such claims; this section has the sole purpose of protecting the integrity of the free software distribution system which is implemented by public license practices. Many people have made generous contributions to the wide range of software distributed through that system in reliance on consistent application of that system; it is up to the author/donor to decide if he or she is willing to distribute software through any other system and a licensee cannot impose that choice.

This section is intended to make thoroughly clear what is believed to be a consequence of the rest of this License.

12. If the distribution and/or use of the Library is restricted in certain countries either by patents or by copyrighted interfaces, the original copyright holder who places the Library under this License may add an explicit geographical distribution limitation excluding those countries, so that distribution is permitted only in or among countries not thus excluded. In such case, this License incorporates the limitation as if written in the body of this License.
13. The Free Software Foundation may publish revised and/or new versions of the Lesser General Public License from time to time. Such new versions will be similar in spirit to the present version, but may differ in detail to address new problems or concerns.

Each version is given a distinguishing version number. If the Library specifies a version number of this License which applies to it and “any later version”, you have the option of following the terms and conditions either of that version or of any later version published by the Free Software Foundation. If the Library does not specify a license version number, you may choose any version ever published by the Free Software Foundation.

14. If you wish to incorporate parts of the Library into other free programs whose distribution conditions are incompatible with these, write to the author to ask for permission. For software which is copyrighted by the Free Software Foundation, write to the Free Software Foundation; we sometimes make exceptions for this. Our decision will be guided by the two goals of preserving the free status of all derivatives of our free software and of promoting the sharing and reuse of software generally.

NO WARRANTY

15. BECAUSE THE LIBRARY IS LICENSED FREE OF CHARGE, THERE IS NO WARRANTY FOR THE LIBRARY, TO THE EXTENT PERMITTED BY APPLICABLE LAW. EXCEPT WHEN OTHERWISE STATED IN WRITING THE COPYRIGHT HOLDERS AND/OR OTHER PARTIES PROVIDE THE LIBRARY “AS IS” WITHOUT WARRANTY OF ANY KIND, EITHER EXPRESSED OR IMPLIED, INCLUDING, BUT NOT LIMITED TO, THE IMPLIED WARRANTIES OF MERCHANTABILITY AND FITNESS FOR A PARTICULAR PURPOSE. THE ENTIRE RISK AS TO THE QUALITY AND PERFORMANCE OF THE LIBRARY IS WITH YOU. SHOULD THE LIBRARY PROVE DEFECTIVE, YOU ASSUME THE COST OF ALL NECESSARY SERVICING, REPAIR OR CORRECTION.
16. IN NO EVENT UNLESS REQUIRED BY APPLICABLE LAW OR AGREED TO IN WRITING WILL ANY COPYRIGHT HOLDER, OR ANY OTHER PARTY WHO MAY MODIFY AND/OR REDISTRIBUTE THE LIBRARY AS PERMITTED ABOVE, BE LIABLE TO YOU FOR DAMAGES, INCLUDING ANY GENERAL, SPECIAL, INCIDENTAL OR CONSEQUENTIAL DAMAGES ARISING OUT OF THE USE OR INABILITY TO USE THE LIBRARY (INCLUDING BUT NOT LIMITED TO LOSS OF DATA OR DATA BEING RENDERED INACCURATE OR LOSSES SUSTAINED BY YOU OR THIRD PARTIES OR A FAILURE OF THE LIBRARY TO OPERATE WITH ANY OTHER SOFTWARE), EVEN IF SUCH HOLDER OR OTHER PARTY HAS BEEN ADVISED OF THE POSSIBILITY OF SUCH DAMAGES.

END OF TERMS AND CONDITIONS

How to Apply These Terms to Your New Libraries

If you develop a new library, and you want it to be of the greatest possible use to the public, we recommend making it free software that everyone can redistribute and change. You can do so by permitting redistribution under these terms (or, alternatively, under the terms of the ordinary General Public License).

To apply these terms, attach the following notices to the library. It is safest to attach them to the start of each source file to most effectively convey the exclusion of warranty; and each file should have at least the “copyright” line and a pointer to where the full notice is found.

Copyright ©

This library is free software; you can redistribute it and/or modify it under the terms of the GNU Lesser General Public License as published by the Free Software Foundation; either version 2.1 of the License, or (at your option) any later version. This library is distributed in the hope that it will be useful, but WITHOUT ANY WARRANTY; without even the implied warranty of MERCHANTABILITY or FITNESS FOR A PARTICULAR PURPOSE. See the GNU Lesser General Public License for more details.

You should have received a copy of the GNU Lesser General Public License along with this library; if not, write to the Free Software Foundation, Inc., 59 Temple Place, Suite 330, Boston, MA 02111-1307 USA

Also add information on how to contact you by electronic and paper mail.

You should also get your employer (if you work as a programmer) or your school, if any, to sign a “copyright disclaimer” for the library, if necessary.

Here is a sample; alter the names:

Yoyodyne, Inc., hereby disclaims all copyright interest in the library ‘Frob’ (a library for tweaking knobs) written by James Random Hacker.

, 1 April 1990

Ty Coon, President of Vice

That’s all there is to it!

The BSD Copyright

This product includes software to which the BSD license applies.

Please note that we cannot respond to inquiries regarding the content of the source code.

The BSD License

Copyright © The Regents of the University of California.

All rights reserved.

Redistribution and use in source and binary forms, with or without modification, are permitted provided that the following conditions are met:

1. Redistributions of source code must retain the above copyright notice, this list of conditions and the following disclaimer.
2. Redistributions in binary form must reproduce the above copyright notice, this list of conditions and the following disclaimer in the documentation and/or other materials provided with the distribution.
3. Neither the name of the University nor the names of its contributors may be used to endorse or promote products derived from this software without specific prior written permission.

THIS SOFTWARE IS PROVIDED BY THE REGENTS AND CONTRIBUTORS "AS IS" AND ANY EXPRESS OR IMPLIED WARRANTIES, INCLUDING, BUT NOT LIMITED TO, THE IMPLIED WARRANTIES OF MERCHANTABILITY AND FITNESS FOR A PARTICULAR PURPOSE ARE DISCLAIMED. IN NO EVENT SHALL THE REGENTS OR CONTRIBUTORS BE LIABLE FOR ANY DIRECT, INDIRECT, INCIDENTAL, SPECIAL, EXEMPLARY, OR CONSEQUENTIAL DAMAGES (INCLUDING, BUT NOT LIMITED TO, PROCUREMENT OF SUBSTITUTE GOODS OR SERVICES; LOSS OF USE, DATA, OR PROFITS; OR BUSINESS INTERRUPTION) HOWEVER CAUSED AND ON ANY THEORY OF LIABILITY, WHETHER IN CONTRACT, STRICT LIABILITY, OR TORT (INCLUDING NEGLIGENCE OR OTHERWISE) ARISING IN ANY WAY OUT OF THE USE OF THIS SOFTWARE, EVEN IF ADVISED OF THE POSSIBILITY OF SUCH DAMAGE.

This product includes software thttpd to which the license below applies.
Please note that we cannot respond to inquiries regarding the content of the source code.

Copyright © 1995, 1998, 1999, 2000, 2001 by Jef Poskanzer <jef@acme.com>.
All rights reserved.

Redistribution and use in source and binary forms, with or without modification, are permitted provided that the following conditions are met:

1. Redistributions of source code must retain the above copyright notice, this list of conditions and the following disclaimer.
2. Redistributions in binary form must reproduce the above copyright notice, this list of conditions and the following disclaimer in the documentation and/or other materials provided with the distribution.

THIS SOFTWARE IS PROVIDED BY THE AUTHOR AND CONTRIBUTORS "AS IS" AND ANY EXPRESS OR IMPLIED WARRANTIES, INCLUDING, BUT NOT LIMITED TO, THE IMPLIED WARRANTIES OF MERCHANTABILITY AND FITNESS FOR A PARTICULAR PURPOSE ARE DISCLAIMED. IN NO EVENT SHALL THE AUTHOR OR CONTRIBUTORS BE LIABLE FOR ANY DIRECT, INDIRECT, INCIDENTAL, SPECIAL, EXEMPLARY, OR CONSEQUENTIAL DAMAGES (INCLUDING, BUT NOT LIMITED TO, PROCUREMENT OF SUBSTITUTE GOODS OR SERVICES; LOSS OF USE, DATA, OR PROFITS; OR BUSINESS INTERRUPTION) HOWEVER CAUSED AND ON ANY THEORY OF LIABILITY, WHETHER IN CONTRACT, STRICT LIABILITY, OR TORT (INCLUDING NEGLIGENCE OR OTHERWISE) ARISING IN ANY WAY OUT OF THE USE OF THIS SOFTWARE, EVEN IF ADVISED OF THE POSSIBILITY OF SUCH DAMAGE.

This product includes software ucd-snmp to which the license below applies.
Please note that we cannot respond to inquiries regarding the content of the source code.

----- Part 1: CMU/UCD copyright notice: (BSD like) -----

Copyright 1989, 1991, 1992 by Carnegie Mellon University

Derivative Work - 1996, 1998-2000

Copyright 1996, 1998-2000 The Regents of the University of California

All Rights Reserved

Permission to use, copy, modify and distribute this software and its documentation for any purpose and without fee is hereby granted, provided that the above copyright notice appears in all copies and that both that copyright notice and this permission notice appear in supporting documentation, and that the name of CMU and The Regents of the University of California not be used in advertising or publicity pertaining to distribution of the software without specific written permission.

CMU AND THE REGENTS OF THE UNIVERSITY OF CALIFORNIA DISCLAIM ALL WARRANTIES WITH REGARD TO THIS SOFTWARE, INCLUDING ALL IMPLIED WARRANTIES OF MERCHANTABILITY AND FITNESS. IN NO EVENT SHALL CMU OR THE REGENTS OF THE UNIVERSITY OF CALIFORNIA BE LIABLE FOR ANY SPECIAL, INDIRECT OR CONSEQUENTIAL DAMAGES OR ANY DAMAGES WHATSOEVER RESULTING FROM THE LOSS OF USE, DATA OR PROFITS, WHETHER IN AN ACTION OF CONTRACT,

NEGLIGENCE OR OTHER TORTIOUS ACTION, ARISING OUT OF OR IN CONNECTION WITH THE USE OR PERFORMANCE OF THIS SOFTWARE.

----- Part 2: Networks Associates Technology, Inc. copyright notice (BSD) -----

Copyright © 2001, Networks Associates Technology, Inc.
All rights reserved.

Redistribution and use in source and binary forms, with or without modification, are permitted provided that the following conditions are met:

- Redistributions of source code must retain the above copyright notice, this list of conditions and the following disclaimer.
- Redistributions in binary form must reproduce the above copyright notice, this list of conditions and the following disclaimer in the documentation and/or other materials provided with the distribution.
- Neither the name of the NAI Labs nor the names of its contributors may be used to endorse or promote products derived from this software without specific prior written permission.

THIS SOFTWARE IS PROVIDED BY THE COPYRIGHT HOLDERS AND CONTRIBUTORS "AS IS" AND ANY EXPRESS OR IMPLIED WARRANTIES, INCLUDING, BUT NOT LIMITED TO, THE IMPLIED WARRANTIES OF MERCHANTABILITY AND FITNESS FOR A PARTICULAR PURPOSE ARE DISCLAIMED. IN NO EVENT SHALL THE COPYRIGHT HOLDERS OR CONTRIBUTORS BE LIABLE FOR ANY DIRECT, INDIRECT, INCIDENTAL, SPECIAL, EXEMPLARY, OR CONSEQUENTIAL DAMAGES (INCLUDING, BUT NOT LIMITED TO, PROCUREMENT OF SUBSTITUTE GOODS OR SERVICES; LOSS OF USE, DATA, OR PROFITS; OR BUSINESS INTERRUPTION)

HOWEVER CAUSED AND ON ANY THEORY OF LIABILITY, WHETHER IN CONTRACT, STRICT LIABILITY, OR TORT (INCLUDING NEGLIGENCE OR OTHERWISE) ARISING IN ANY WAY OUT OF THE USE OF THIS SOFTWARE, EVEN IF ADVISED OF THE POSSIBILITY OF SUCH DAMAGE.

---- Part 3: Cambridge Broadband Ltd. copyright notice (BSD) ----

Portions of this code are copyright © 2001, Cambridge Broadband Ltd.
All rights reserved.

Redistribution and use in source and binary forms, with or without modification, are permitted provided that the following conditions are met:

- Redistributions of source code must retain the above copyright notice, this list of conditions and the following disclaimer.
- Redistributions in binary form must reproduce the above copyright notice, this list of conditions and the following disclaimer in the documentation and/or other materials provided with the distribution.
- The name of Cambridge Broadband Ltd. may not be used to endorse or promote products derived from this software without specific prior written permission.

THIS SOFTWARE IS PROVIDED BY THE COPYRIGHT HOLDER "AS IS" AND ANY EXPRESS OR IMPLIED WARRANTIES, INCLUDING, BUT NOT LIMITED TO, THE IMPLIED WARRANTIES OF MERCHANTABILITY AND FITNESS FOR A PARTICULAR PURPOSE ARE DISCLAIMED. IN NO EVENT SHALL THE COPYRIGHT HOLDER BE LIABLE FOR ANY DIRECT, INDIRECT, INCIDENTAL, SPECIAL, EXEMPLARY, OR CONSEQUENTIAL DAMAGES (INCLUDING, BUT NOT LIMITED TO, PROCUREMENT OF SUBSTITUTE GOODS OR SERVICES; LOSS OF USE, DATA, OR PROFITS; OR BUSINESS INTERRUPTION) HOWEVER CAUSED AND ON ANY THEORY OF LIABILITY, WHETHER IN CONTRACT, STRICT LIABILITY, OR TORT (INCLUDING NEGLIGENCE OR OTHERWISE) ARISING IN ANY WAY OUT OF THE USE OF THIS SOFTWARE, EVEN IF ADVISED OF THE POSSIBILITY OF SUCH DAMAGE.

MPEG-4 Visual Patent Portfolio License

This product is licensed under the MPEG-4 Visual Patent Portfolio License. For the personal and non-commercial use of a consumer for (i) encoding video in compliance with the MPEG-4 Visual Standard (“MPEG-4 Video”) and/or (ii) decoding MPEG-4 Video that was encoded by a consumer engaged in a personal and non-commercial activity and/or was obtained from a video provider licensed by MPEG LA to provide MPEG-4 Video. No license is granted or shall be implied for any other use.

Additional information including that relating to promotional, internal and commercial uses and licensing may be obtained from MPEG LA, LLC.
See <http://www.mpegla.com>



Glossary

AES/EBU

A standard established jointly by the AES (Audio Engineering Society) and EBU (European Broadcasting Union) for serial transmission of digital audio. Two channels of audio can be transmitted via a single connector.

Clip

A recording unit. Clips are created every time recording starts and stops.

Clip list

A list of locations in the material recorded on the disc, arranged in any order. Clips lists can be created with the scene selection function of this unit, and with the supplied PDZ-1 Proxy Browsing Software.

Color subcarrier

In a composite video signal, a signal superimposed upon the picture (luminance) information for the purpose of conveying the associated color information. Color and saturation information is conveyed by the phase and amplitude of the color subcarrier. Also called subcarrier.

Composite video signal

A video signal in which luminance and chrominance are combined along with timing reference “sync” information to make composite video.

Drop frame mode

SMPTE time code runs at 30 frames/second, while the NTSC color television system runs at about 29.97 frames/second. Drop frame mode adjusts the running of time code to eliminate the discrepancy between time code value and actual time by dropping two frames from the time code value at the beginning of each minute except every tenth minute.

E-E mode

Electric-to-Electric mode. When you operate a VDR in E-E mode, input video and/or audio signals pass

through electric circuits only and then come out from the output connectors, without passing through electromagnetic conversion circuits such as recording heads.

Essence mark

A type of metadata that may be set for a specified frame.

For more efficient searches, XDCAM equipment records essence marks as part of Non-RealTime metadata, and uses them to display thumbnails.

i.LINK

Another name for the IEEE1394-1995 standards and their revisions. XDCAM uses the i.LINK interface to transfer DV streams by the AV/C protocol, and to read and write MPEG IMX and DVCAM data files by FAM (file access mode).

Metadata

Information about the properties of video and audio content. XDCAM records metadata such as UMIDs and essence marks, and the supplied PDZ-1 Proxy Browsing Software can be used to record information such as titles and comments.

MXF

Material eXchange Format. A file exchange format developed by the Pro-MPEG Forum. Equipment from different manufacturers can exchange files in this format.

Non-audio

General term for audio signals other than linear PCM, such as Dolby E¹⁾ and Dolby Digital (AC-3).¹⁾ XDCAM can record non-audio as an input signal.

¹⁾ Dolby is a trademark of Dolby Laboratories.

Non-drop-frame mode

A mode of advancing time code which ignores the difference in frame values between real time and the time code. Using this mode produces a difference of approximately 86 seconds per day between real time and time code, which causes problems when editing programs in units of seconds using the number of frames as a reference.

Proxy AV data

Low-resolution data with a video bandwidth of 1.5 Mbps and an audio bandwidth of 64 kbps per channel. This unit records proxy AV data automatically whenever high-resolution MPEG IMX or DVCAM data is recorded.

Reference video signal

A video signal that contains a sync signal or sync and burst signals, used as a reference for synchronization of video equipment.

SDI

Serial Digital Interface. An interface standardized as SMPTE 259M which enables the transmission of an uncompressed digital component stream.

S/N

Signal-to-Noise ratio. The relation of the strength of the desired signal to the accompanying electronic interference, the noise. If S/N is high, sounds are reproduced with less noise and pictures are reproduced clearly without snow.

SNMP

Simple Network Management Protocol. XDCAM uses this protocol to monitor equipment operating status via network connectors.

Sub clip

One of the sections which make up a clip list. A sub clip may be part of a clip or an entire clip.

Thumbnail image

A reduced still picture of video for display on a GUI screen. XDCAM creates thumbnail images from proxy video, and displays them as index pictures on GUI screens.

Time code

A digitally encoded signal which is recorded with video data to identify each frame of the video by hour, minute, second and frame number. SMPTE time code is applied to NTSC system, and EBU time code to PAL and SECAM systems.

UMID

Unique Material Identifier. A standard (SMPTE 330M) for video and audio metadata. The Basic section of a UMID contains a globally unique number and a material number for the identification of recorded material. An optional section called the “Source Pack” contains information such as the time and location of recording. A UMID with the Basic section only is called a Basic UMID. A UMID with the Source Pack is called an Extended UMID.

User bits

A total of 32 bits are provided in the time code which the user can use to record such information as date, reel number, or scene number on video tape. Also called user's bits.



Index

A

- AC IN connector 24
- AC power
 - inlet connector 11
 - switch 11
- ACCESS indicator 12, 17
- Accessories
 - not supplied 133
 - supplied 133
- AES/EBU 19
- Alarms 122
 - list 122
- ALL/CH-1, CH-2 to CH-4 adjustment
 - knobs 15
- ANALOG 19
- Analog
 - audio signal inputs/outputs 23
 - interfaces 10
 - video signal inputs/outputs 23
- Appendixes 131
- Arrow buttons 16
- AUDIO
 - IN 1/3, 2/4 connectors 23
 - METER SEL button 15
 - OUT connectors 23
- Audio
 - settings section 15
- Audio and video settings section 19
- AUDIO INPUT
 - CH button 19
 - SEL button 19
- Audio level
 - meters 18
- AUDIO MONITOR
 - SEL button 15
- Audio recording
 - format setting 43
 - level adjustment 43
- Auto clip list recording 48

B

- Basic setup menu 90
 - items 90
 - operations 94
- BATT display 18
- Battery pack shoe 11
- Battery packs 33
- Built-in speaker (monaural) 11

C

- Carrying handle 11

CHARACTER switch 20

- Clip 60
 - deleting 56, 118
 - locking 55
 - status 118
 - user-defined name 76

Clip List

- previewing 66
- Clip list 60
 - CLIP menu 68
 - creating and editing 61
 - current clip list 60
 - deleting 69
 - managing 68
 - previewing 66
 - saving 66
 - sorting 70
 - user-defined name 76

Condensation 121

Configuration 11

Connections 25

- Camcorder 27
 - cut editing system 29
 - external monitor 25
 - for using PDZ-1 25
 - nonlinear editing system 27

Connectors 11, 21

Control panel 11, 12

COUNTER 13

- indicator 18
- SEL button 13

Current clip list 60

Cut editing system connection 29

D

- Date/time setting 34
- DC IN 12V connector 24
- DC OUT 12V connector 21
- DC power, using 33
- Digital
 - audio signal inputs/outputs 22
 - hours meter 120
 - interfaces 10
- DIGITAL AUDIO (AES/EBU)
 - IN 1/2, 3/4 connectors 22
 - OUT 1/2, 3/4 connectors 22
- Disc loaded mark 19
- DISC remaining capacity indicator 18
- Discs
 - formatting 39
 - handling 38
 - loading/unloading 38
 - status 118
 - usable discs 38
 - write-protecting 38
- Display settings section 19
- Drop frame mark 36

E

- EJECT button 11
- Ejecting a disc manually 39
- Error Messages 121
- Essence mark 53
- Essence mark recording 48, 51
- Extended setup menu 97
 - items 97
 - operations 108
- External monitor connection 25
- EXT-LK indicator 18

F

- Features of PDW-R1 9
- File access mode
 - file operations 78
- File operations 72
 - directory structure 72
 - file access mode 78
 - FTP 80
 - restrictions 73
- Formatting a disc 39
- Forward high-speed search 16
- Front panel 12
- F-RUN/R-RUN switch 13
- FTP
 - command lists 82
 - file operations 80

G

- Glossary 149

H

- HOLD button 13
- HOLD indicator 18

I

- i.LINK connector 22
- IN indicator 16
- IN/OUT button 16
- Indicators on back of LCD panel 17
- Initial value 44
- INT/EXT/RP188 switch 13
- Interfaces 10

J

- Jog
 - dial 14
 - mode 51
- JOG button 14
- Jog/shuttle control block 14
- Jog/shuttle transport indicators 14

K

- KEY INHI indicator 17
- KEY INHI switch 12

L

- LCD panel 11, 17
- Level adjustment 43
- LEVEL knob 21
- LIGHT switch 20
- Line mode
 - setting 7
- Live logging function 71
- Loading/unloading a disc 38
- LOCAL 12

M

- Maintenance 72, 120
 - periodic 120
- Maintenance menu 112
 - items 112
 - operations 114
- MARK1/MARK2 button 16
- MENU button 14
- Menus 89
 - basic setup menu 90
 - configuration 89
 - extended setup menu 97
 - maintenance menu 112
 - system menu 117
- Metadata 10
- MONITOR switch 20

N

- Names and functions of parts 11
- NDF indicator 18
- NETWORK 12
 - access indicator 12
- Network connector 22
- NEXT button 16
- Nonlinear editing system
 - connection 27

O

- On/standby
 - indicator 12, 17
 - switch 12
- Operating mode selection/menu setting section 13
- Operation mode 36
- OUT indicator 16
- Overview 9

P

- PB indicator 18

- PDZ-1 25, 71
 - connections 25
 - installation 71
 - system requirements 71
- Periodic maintenance 120
- PHONES jack 21
- PLAY button 16
- Playback 49, 51
 - clip list 54
 - condition displays 37
 - jog mode 51
 - normal speed 51
 - preparations 49
 - repeat 54
 - shuttle mode 52
 - start position 49
- Power
 - AC power 33
 - battery packs 33
 - preparations 33
- Power supply section 24
- Preparations 25
- PRESET/REGEN switch 13
- PREV button 16
- Proxy AV data 9
- Proxy Browsing Software (See also "PDZ-1") 25, 71

Q

- Quick scene selection 62

R

- REC button 16
- REC INHI indicator 18
- Recording 42
 - essence mark 48, 51
 - format setting 42
 - level adjustment 43
 - operation 48
 - preparations 42
 - time code/user bits 44
- Recording and playback control section 16
- REF VIDEO IN connectors 22
- Related products 133
- REMOTE 12
 - connector 22
- Remote control switch 12
- Repeat playback 54
- RESET button 14
- Reverse high-speed search 16
- RM-280 31

S

- S400 connector 22
- Salvage function 40

- Scene selection 58
- SDI 19
 - IN connector 23
 - OUT (SUPER) connectors 23
 - signal inputs/outputs 23
- Security slot 11
- SET button 14
- Setup 34
- SETUP BANK4 113
- SG 19
- SHIFT button 14
- Shoulder belt
 - posts 11
 - using 134
- Shuttle
 - dial 15
 - mode 52
- SHUTTLE button 14
- SNMP 10
- Specifications 131
- STATUS button 19
- Status display 18
- STOP button 16
- Sub clip 60
 - deleting 66
 - reordering 63
 - trimming 65
- SUBCLIP button 13
- Superimposed text information (See also "Text information") 35
- System menu 117
 - items 117
 - operations 117

T

- TC 13
- TC/VITC indicator 18
- Text information 35
 - display adjustment 35
 - drop frame mark 36
 - information displayed 35
 - operation mode 36
 - TC generator drop frame mark 36
 - time data types 36
 - VITC field mark 36
- THUMBNAIL button 13
- Thumbnail image, setting 43
- Thumbnail search 9, 52
- TIME CODE
 - IN connector 24
 - OUT connector 24
- Time code
 - initial value 44
 - inputs/outputs 24
 - recording 44, 88
- Time data
 - display 18

types 36
Time data settings section 13
Title 75
Troubleshooting 120

U

UB/VIUB indicator 18
U-BIT 13
UMID data 109
User bit recording 44

V

VARIABLE switch 15
VIDEO
 IN connectors 23
 INPUT SEL button 19
 OUT 1, OUT 2 (SUPER)
 connectors 23
Video panel 17
Video processing
 adjusting parameters 49
Video recording format setting 43
VITC
 field mark 36
 indicator 18

W

WARNING indicator 17
Write-protecting discs 38



The material contained in this manual consists of information that is the property of Sony Corporation and is intended solely for use by the purchasers of the equipment described in this manual.

Sony Corporation expressly prohibits the duplication of any portion of this manual or the use thereof for any purpose other than the operation or maintenance of the equipment described in this manual without the express written permission of Sony Corporation.

